

CONTRACT DOCUMENTS AND
TECHNICAL SPECIFICATIONS
FOR

**BRIDGE REHABILITATION PROJECT
CACHE ROAD OVER WOLF CREEK
PROJECT NO. EN2112**

CITY OF LAWTON

COMANCHE COUNTY, OKLAHOMA

SET NO.: _____

DATE: October 28, 2024

PREPARED BY:

H.W. LOCHNER, INC.

6301 Waterford Blvd, Suite 310

Oklahoma City, OK 73118

Certificate of Authorization Number: 6131

Certificate of Authorization Renewal Date: 06/30/2025

In Coordination with:

City of Lawton

Engineering Department

212 SW 9th Street

Lawton, Oklahoma 73501

CONTRACT DOCUMENTS

AND

TECHNICAL SPECIFICATIONS

FOR

**BRIDGE REHABILITATION
CACHE ROAD OVER WOLF CREEK
PROJECT NO. EN2112**

for

CITY OF LAWTON
COMANCHE COUNTY, OKLAHOMA

Prepared by:

Approved: November 5, 2024

H.W. Lochner, Inc.
6301 Waterford Blvd, Suite 310
Oklahoma City, OK 73118
(405) 748-6651
CA Number: 6131, CA Renewal Date: 6/30/2025

In Coordination with:

City of Lawton
Engineering Department
212 SW 9th Street
Lawton, Oklahoma 73501
(580) 581-3385

Stan Booker, Mayor

John Ratliff, City Manager



10/28/2024

Troy D. Travis

Troy D. Travis, P.E.
Engineer of Record
H.W. Lochner, Inc.

Mike Jones
Interim Director of Engineering

<u>Notice to Bidders</u> <i>Public Construction Contract</i>		Date of Notice: November 6, 2024	Date Documents Available: November 6, 2024
SUBMISSION LOCATION & TIME: BY 2:00 P.M. December 4, 2024 City Clerk, City Hall 212 SW 9th Street Lawton, OK 73501 Phone: 580.581.3305			
Bid Opening: Date: Wednesday, December 4, 2024 Time: 2:00 p.m. Location: 212 SW 9th Street, Lawton OK 3rd Floor Conference Room, City Hall			
Project Title: EN2112 : BRIDGE REHABILITATION PROJECT, CACHE ROAD OVER WOLF CREEK			
Bid Instructions: Bids timely filed with the City Clerk shall be publicly opened and read aloud at the time and location specified as bids above. Bids received more than ninety six (96) hours, excluding Saturdays, Sundays and holidays, before the time set for opening of bids, as well received after the time set for opening of bids, will not be considered and will be returned unopened. Within sixty (60) days from the bid opening date, the successful bidder shall execute a written contract embodying all provisions of the bidding documents.			
For Technical Information, contact: Troy Travis, Engineer of Record Phone Number: (405) 748-6651			
Description of Work: Rehabilitate existing bridges and perform other work as shown on the plans.			
Time for Project Completion: 180 Calendar Days		*Wage Rates: YES	
Plans, Specs & Bidding Document Available at: H.W. Lochner, Inc, (Documents will be available in digital format) 6301 Waterford Blvd, Suite 310 OKC, OK 73118 8:00 a.m. to 5:00 p.m. Monday through Friday Phone: 405.748.6651		Deposit for Plans & Specs: N/A – digital format (email)	
Prebid Conference			
Location: 212 SW 9th Street Lawton, Oklahoma (City Hall/3rd Floor Conference Room)		Time: 10:00 a.m. Date: November 15, 2024	Attendance Mandatory? NO
Bid Bond: A cashier's check, a certified check, or a surety bond in the amount of five percent (5%) of the bid shall accompany the sealed proposal of each bidder. Deposits will be returned to the unsuccessful bidders. Deposits will be returned to successful bidder upon execution of contract documents.			
Prime contractors must provide adequate previous similar project experience, and verifiable references, that exhibits the prime's ability to self-perform and execute this project within the contract requirements as set forth in the plans and specifications. The City of Lawton reserves the right to reject any and all bids based on prior project experience or lack thereof.			
*Bids shall also be made in accordance with the prevailing hourly rate of wages for this locality and project as determined by the Commission of Labor and filed with the Secretary of State, a copy of which is on file with the City Clerk, in accordance with the provisions of 40 O.S. 1971, 196.1-196.12, which prevailing hourly rate of wages is made a part of this notice by reference as though fully set forth herein.			
THE CITY COUNCIL OF THE CITY OF LAWTON RESERVES THE RIGHT TO REJECT ANY OR ALL BIDS. CITY OF LAWTON, OKLAHOMA By: Donalynn Blazek-Scherler, City Clerk			

CONTRACT DOCUMENTS AND
 TECHNICAL SPECIFICATIONS
 FOR CONSTRUCTION OF
BRIDGE REHABILITATION
CACHE ROAD OVER WOLF CREEK
PROJECT NO. EN2112
 CITY OF LAWTON
 COMANCHE COUNTY, OKLAHOMA

CONTENTS

	Page
I. Contract Documents	
A. Table of Contents	4
B. Solicitation for Bids	5
C. Information for Bidders.....	7
D. Bidding Documents:	
1. Contractor's Checklist of Required Items	14
2. Bid Proposal.....	15
3. Bid Bond.....	18
4. Anticollusion Affidavit.....	20
5. Business Relationships Affidavit.....	22
6. Experience & Capability Questionnaire	23
E. Contract	26
F. Performance Bond	31
G. Statutory Bond	33
H. Maintenance Bond	35
I. General Conditions Contents.....	37
J. General Conditions.....	38
K. Forms:	
1. Work Order	69
2. Affidavit for Payment	70
3. Payment Certificate.....	71
4. Contractor's Release to the City.....	72
5. Waiver and Release of Lien.....	73
II. Technical Specifications	
III. Special Provisions	
IV. Plans (Sheets 1 – 29)	

SOLICITATION FOR BIDS

NOTICE is hereby given that the CITY OF LAWTON, OKLAHOMA, will receive sealed bids at the Office of the City Clerk, City Hall, 212 SW 9th St, Lawton, Oklahoma, 73501, until 2:00 o'clock P.M., Local Time, on the 6th day of November, 2024, for the construction of

BRIDGE REHABILITATION
CACHE ROAD OVER WOLF CREEK
PROJECT NO. EN2112

1. Bid Requirements.

- a. Bids shall be made in accordance and fully comply with

Solicitation for Bids
Bidder's Proposal

Requirements for Bidders
Plans and Specifications

and other bidding documents on file and available for examination at the Office of the City Clerk in City Hall. These documents are made a part of this notice as though fully set forth herein.

- b. Bids may require compliance with the prevailing hourly rate of wages for this locality and project as determined by the Commission of Labor and filed with the Secretary of State, a copy of which is on file with the City Clerk, in accordance with the provisions of 40 Oklahoma Statute 1991, 196.1-196.14, which prevailing hourly rate of wages is made a part of this solicitation by reference as though fully set forth herein.
- c. A cashier's check, a certified check, or a surety bond in the amount of five percent (5%) of the bid shall accompany the sealed proposal of each bidder. Such deposits will be returned to the unsuccessful bidders.

2. Filing of Bids.

- a. Bids received more than ninety-six (96) hours before the time set for opening of bids, (excluding Saturdays, Sundays, and holidays), and bids received after the time set for opening of bids will not be considered and will be returned unopened.
- b. Bids timely filed with the City Clerk shall be publicly opened and read aloud in the Auditorium at City Hall immediately after the closing time above stated. No bidder may withdraw a bid within sixty (60) days after the actual date of the opening thereof. Within sixty (60) days from the bid date, the owner may award a contract to the successful bidder or reject any or all bids for the project.

3. Obtaining Documents.

Complete sets of the Plans, Specifications and all other bidding documents may be obtained from H.W. Lochner, Inc., 6301 Waterford Blvd, Suite 310, OKC, OK

73118 (phone [405] 748-6651) in digital format.

4. A **PRE-Bid Conference** will be held at **212 SW 9th Street, 3rd Floor Conference Room, City Hall**, Lawton, Oklahoma at **10:00 a.m.**, Local Time, on **November 15th, 2024**.
5. The City Council of the City of Lawton reserves the right to reject any or all bids.

For the CITY OF LAWTON, OKLAHOMA

BY: _____
Donalynn Blazek-Scherler, City Clerk

INFORMATION FOR BIDDERS

1. Receipt and Opening of Bids

The City of Lawton (herein called the "Owner") invites bids on the forms attached hereto, all blanks of which must be appropriately filled in. Bids will be received by the Owner at the Office of the City Clerk until 2:00 o'clock, P.M., Local Time on **December 4, 2024**, and then at 2:00 will be publicly opened and read aloud at the 3rd Floor Conference Room, City Hall, at 212 SW 9th Street, Lawton, Oklahoma. The envelopes containing the bids must be sealed, addressed to the City Clerk, 212 SW 9th Street, Lawton, Oklahoma, 73501, and designated as bid for the

BRIDGE REHABILITATION **CACHE ROAD OVER WOLF CREEK** **PROJECT NO. EN2112**

The Owner may consider informal any bid not prepared and submitted in accordance with the provisions hereof and may waive any informalities or reject any and all bids. Any bid may be withdrawn prior to the above scheduled time for the opening of bids or authorized postponement thereof. Any bid received after the time and date specified shall not be considered. No bidder may withdraw a bid within sixty (60) days after the actual date of the opening thereof.

2. Preparation of Bid

Each bid must be submitted on the prescribed forms. All blanks and spaces for bid prices must be filled in, in ink or typewritten, in both words and figures, and the foregoing certifications must be fully completed and executed when submitted.

Bids and affidavits must be filed in sealed envelopes within the time limit for receiving proposals, as stated in the SOLICITATION FOR BIDS. Bid envelopes shall legibly bear the word "PROPOSAL" with the name of the Project. If forwarded by mail, the sealed envelope containing the bid **must** be enclosed in another envelope addressed as specified in the bid form. The original copy shall be filed with the CITY OF LAWTON in the CITY CLERK's office in the LAWTON CITY HALL. All blank spaces in the proposal forms shall be correctly filled-in and the bidder shall state the prices, typewritten or written in ink, both in words and numerals, for which he proposes to do the work contemplated or furnish the materials required. All prices shall be distinctly legible.

3. Method of Bidding

The Owner invites the following bid(s): **UNIT PRICE**

4. Bid Surety

Each bid must be accompanied by cash, certified check of the bidder, or a bid bond prepared on the form of bid bond attached hereto, duly executed by the bidder as principal and having as surety thereon a surety company approved by the Owner, in the amount of five percent (5%) of the bid. Such cash, checks, or bid bonds will be returned promptly after the Owner and the

accepted bidder have executed the contract, or, if no award has been made within 60 days after the opening of bids, upon demand of the bidder at any time thereafter, so long as he has not been notified of the acceptance of his bid.

Proposals will not be considered unless the original filed with the City is accompanied by the described Bid Surety made payable to the City of Lawton. The proposal guaranty is required as evidence of good faith and as a guarantee that, if awarded the contract, the bidder will execute the contract and furnish the required bonds.

The successful bidder, upon his failure or refusal to execute and deliver the contract and bonds required within ten (10) days after he has received notice of the acceptance of his bid, shall forfeit to the Owner, as liquidated damages for such failure or refusal, the security deposited with his bid.

5. Telegraphic Modification

Any bidder may modify his bid by telegraphic communication at any time prior to the scheduled closing time for receipt of bids, provided such telegraphic communication is received by the Owner prior to the closing time; and, provided further, the Owner is satisfied that a written confirmation of the telegraphic modification over the signature of the bidder was mailed prior to the closing time. The telegraphic communication should not reveal the bid price but should provide the addition or subtraction or other modification so that the final prices or terms will not be known by the Owner until the sealed bid is opened. If written confirmation is not received within two (2) days from the closing time, no consideration will be given to the telegraphic modification.

6. Qualification/Disqualification of Bidders

The Owner may make such investigations as he deems necessary to determine the ability of the bidder to perform the work, and the bidder shall furnish to the Owner all such information and data for this purpose as the Owner may request. The Owner reserves the right to reject any bid if the evidence submitted by, or investigation of, such bidder fails to satisfy the Owner that such bidder is properly qualified to carry out contract requirements and complete the work contemplated therein. Conditional bids will not be accepted.

Bidders will be disqualified and their proposals not considered for any of the following specific reasons (These reasons are not all inclusive):

1. Where more than one proposal for an individual firm, partnership, or corporation is filed under the same or different names; and where such proposals are not identical in every respect
2. Reason for believing that collusion exists among the bidders
3. Reasonable grounds for believing that the bidder holds interest in more than one proposal for the work contemplated or materials to be furnished
4. Incomplete work that, in the judgment of the City, will hinder or prevent the prompt commencement or completion of this project

7. Power of Attorney

Attorneys-in-fact who sign bid bonds or contract bonds must submit with each bond a certified and effectively dated copy of their power of attorney.

If the proposal is submitted by an individual, his name must be signed by him or his duly authorized agent and his post office address given. If the proposal is submitted by a firm or partnership, the name and post office address of each member of the firm must be given with the proposal signed by a duly authorized member of the firm or partnership. If the proposal is made by a company or corporation, the state in which the company or corporation is chartered and business address must be given; and the proposal must be signed by a duly authorized official or agent. Powers of Attorney, authorizing agents, or others to sign proposals must be properly certified and on file with the City Clerk.

8. Time of Completion and Liquidated Damages

The Contractor hereby agrees to commence work under the Contract on a date specified in a written "Notice to Proceed" of the Owner, and to fully complete the project within **(180) consecutive calendar days**. The Contractor further agrees to pay as liquidated damages, the sum of **Two Thousand Dollars and 00/100 (\$2,000.00) for each consecutive calendar day** thereafter as provided in the Contract and General Conditions.

9. Rejection of Proposals

The City reserves the right to reject any or all proposals submitted, all of which are subject to this reservation. Proposals shall be rejected for any of the following specified reasons (These reasons are not all inclusive):

1. Proposals received after the time limit stated in the solicitation
2. Proposal prices obviously unbalanced
3. Proposals that are incomplete insofar as the Non-Collusion Affidavit, required signatures, or containing any irregularities of substance

10. Notice of Award

The Owner will make every reasonable attempt to award the contract within ten (10) days of the bid opening date, but reserves the right to examine all the bids in their entirety and to take whatever time may be required, in the best interest of the Owner, to accomplish a complete and fair bid analysis.

11. Method of Award - Lowest Responsible Bidder

Award of contract will be made by the City Council, upon recommendation of the City Engineer, to the lowest responsible bidder submitting a responsive bid and meeting the requirements of the City. The Owner may reject all bids or may award the contract with any selected alternatives based upon available funding.

12. Cancellation of Award

The City reserves the right to cancel the award of any contract at any time before the execution of said contract without liability against the City.

13. Obligation of Bidder

At the time of the opening of bids, each bidder will be presumed to have inspected the site and to have read and to be thoroughly familiar with the plans and contract documents (including all addenda). The failure or omission of any bidder to examine any form, instrument, or document shall not relieve any bidder from any obligation in respect of his bid.

Each bidder must inform himself fully of the conditions relating to the construction of the project and the employment of labor thereon. Failure to do so will not relieve a successful bidder of his obligation to furnish all material and labor necessary to carry out the provisions of the contract. Insofar as possible, the contractor must employ methods or means that will not cause any interruption of or interference with the work of any other contractor.

All bidders, by submittal of a proposal, represent that they have examined the site prior to submittal and are fully informed regarding facilities and conditions affecting work, costs, risks, and obligations to be met, regardless of any omissions of the specifications.

Any neglect or failure on the part of the bidder to obtain reliable information regarding the conditions to be encountered shall not relieve the successful bidder from any risks or liabilities or from the responsibility for the completion and acceptance of the project.

13. Pre-Bid Conference

A **Non-Mandatory Pre-Bid Conference** will be held at **212 SW 9th Street, Lawton, OK-3rd floor (Conference Room) City Hall**, at **10:00 a.m. on November 15, 2024**.

15. Addenda and Interpretations

No interpretation of the means of the plans, specifications, or other pre-bid documents will be made to any bidder orally.

Each written request for such interpretation should be addressed to the City Engineer at 212 SW 9th Street, Lawton, Oklahoma, 73501. To be given consideration, each such request must be received at least five (5) days prior to the date fixed for the opening of bids. Any and all such interpretations and any supplemental instructions will be in the form of written addenda to the specifications which, if issued, will be mailed by certified mail with return receipt requested to all plan holders (at the respective addresses furnished for such purposes) for the opening of bids. Failure of any bidder to receive any such addendum or interpretation shall not relieve such bidder from any obligation under his bid as submitted. All addenda so listed shall become part of the contract documents.

16. Security for Faithful Performance

The Contractor shall deliver the executed contract and all required surety bonds within ten (10) days upon receipt of the contract from the Owner. With the execution and delivery of the Contract, the Contractor shall furnish and file with the City in the amounts herein required, the surety bonds listed below. The surety on such bonds shall be a duly authorized surety company satisfactory to the Owner.

- A. A good and sufficient Performance Bond in an amount equal to one hundred percent (100%) of the approximate total amount of the Contract, guaranteeing the full and faithful execution of the work and performance of the Contract and for the protection of the City and all property owners interested against any improper execution of the work or the use of inferior materials.
- B. A good and sufficient Statutory Bond in an amount equal to one hundred percent (100%) of the approximate total amount of the Contract, guaranteeing payment for all labor, materials, and equipment used in the construction of the project.
- C. A good and sufficient Maintenance Bond in an amount equal to one hundred percent (100%) of the total amount of the Contract, guaranteeing the maintenance in good condition of such project for a period of two (2) years from and after the time of its completion and acceptance by the City.

No surety will be accepted who is in default or delinquent on any bond or who holds interest in any litigation against the City. All bonds shall be made on forms furnished by the City and shall be executed by surety companies licensed to do business in the State of Oklahoma and shall conform to the requirements as set forth herein. Each Bond shall be executed by the Contractor and the Surety.

Should any surety on the Contract be determined unsatisfactory at any time by the City, notice will be given to the Contractor to that effect; and the Contractor shall forthwith substitute a new Surety or Sureties satisfactory to the City. No payment will be made under the Contract until the new Surety or Sureties, as required, have qualified and have been accepted by the City. The Contract shall not be operative nor shall any payments be due until approval of the bonds has been made by the City.

17. Laws and Regulations

The bidder's attention is directed to the fact that all applicable state laws, municipal ordinances, and the rules and regulations of all authorities having jurisdiction over construction of the project shall apply to the contract throughout and they will be deemed to be included in the contract the same as though herein written out in full.

18. Sales Tax Exemption

Pursuant to Oklahoma Statutes, Title 68, 1356(I0), Contractors and Subcontractors shall be exempted from the tax levied on the sale of tangible personal property or services necessary for the completion of this construction contract. Any Contractor or Subcontractor making purchases for this contract on behalf of the City of Lawton shall certify, in writing, on the copy of the invoice or sales ticket to be retained by the vendor, that the purchases are made for and on behalf of the

City of Lawton.

Contractors and Subcontractors shall request a written Sales Tax Exemption by contacting the Engineering Department, City of Lawton, 212 SW 9th Street, Lawton, Oklahoma, 73501, Ph. (580) 581-3385, who will issue such exemption on an individual project basis. It shall be the Contractor's and Subcontractor's responsibility to secure the Sales Tax Exemption and failure to do so will not lessen their liability for payment of the sales tax.

Two Tax Commission interpretations of the Oklahoma statutes Title 68, 1356(I0) are listed below to avoid contention among the City of Lawton, its contractors, and the Tax Commission:

"Exemptions apply to materials permanently incorporated into the project, but not to concrete forms nor to other tools."

"The same reasoning precludes exceptions being applied to rental items."

The Contractor shall certify that purchases are made for or are on behalf of the City of Lawton. Persons who make wrongful or erroneous certification(s) shall be guilty of a misdemeanor and shall be punished as provided in the statutes.

19. Safety Standards and Accident Prevention

With respect to all work performed under this contract, the Contractor shall:

1. Comply with the safety standard provisions of applicable laws, building and construction codes, and the "Manual of Accident Prevention in Construction" published by the Associated General Contractors of America, the requirements of the Occupational Safety and Health Act of 1970 (Public Law 91-596), and the requirements of Title 29 of the Code of Federal Regulations.
2. Exercise every precaution at all times for the prevention of accidents and the protection of persons (including employees) and property.
3. Maintain as required by OSHA standards, all required articles necessary for giving first aid to the injured.

20. Access to Site

Access to the site is illustrated on the location map. It shall be the Contractor's responsibility to determine restrictions, if any, as to loads, bridge and road clearances, channel depths, and private property limitations that may influence access to the site.

21. Notice of Special Conditions

Attention is particularly called to those parts of the contract documents and specifications which deal with the following:

- a. Time for Completion and Liquidated Damages
- b. Wage rates and Insurance Requirements
- c. Inspection and Testing of Materials
- d. Stated allowances

22. Payments to Contractor

The Owner will make progress payments to the Contractor no more than once per month upon request of the Contractor. Pay requests take approximately 3-4 weeks to process.

Such payment will be made on the basis of an agreed estimate of work performed since the previous pay request, provided that the Contractor and the City Engineer shall have previously come to an agreement as to the amount of the request prior to submission.

The City shall retain 5% of the amount of each estimate until the project is complete.

CONTRACTOR'S CHECKLIST OF REQUIRED ITEMS

		Completed*
1.	Bid Proposal	_____
2.	Bid Bond	_____
3.	Anti-Collusion Affidavit	_____
4.	Business Relationships Affidavit	_____
5.	Experience and Capability Questionnaire	_____

*Check when filled out, signed, and included with submission of bid packet.

BID PROPOSAL

Date: November 6, 2024

The Honorable Mayor and City Council
City of Lawton
212 SW 9th Street
Lawton, Oklahoma 73501

RE: Proposal of _____ (hereinafter called "Bidder") a corporation/partnership/individual (strike out inapplicable term) organized and existing under the laws of the State of Oklahoma.

Gentlemen:

The Bidder, in compliance with your invitation for bids for the construction of

BRIDGE REHABILITATION
CACHE ROAD OVER WOLF CREEK
PROJECT NO. EN2112

having examined the Plans and Specifications with related documents and the site of the proposed work, and being familiar with all of the conditions surrounding construction of the proposed project (including availability of material and labor), hereby proposes to furnish all labor, materials, and supplies to construct the project in accordance with the Contract Documents, within the time set forth therein, and at the prices stated below. These prices are to cover all expenses incurred in performing the work required under the Contract Documents, of which this Proposal will be made a part.

Bidder hereby agrees to commence work under this contract on a date to be specified in written "Notice to Proceed" of the Owner and to fully complete the project within **One Hundred Eighty (180) consecutive calendar days** thereafter as stipulated in the Specifications. Bidder further agrees to pay as liquidated damages the sum of **Two Thousand and 00/00 Dollars (\$2,000.00) for each consecutive calendar day** thereafter that the Contract is not completed as provided in the General Conditions.

Bidder acknowledges receipt of the following Addenda:

Bidder agrees to perform all of the construction work described in the Specifications and shown on the Drawings for the following **UNIT PRICES**:

BID SCHEDULE
BRIDGE REHABILITATION
CACHE ROAD OVER WOLF CREEK
PROJECT NO. EN2112
BASE BID

Bid Proposal Form

PAY QUANTITIES

ITEM NO.	SPEC NO.		DESCRIPTION	UNIT	QUANTITY	UNIT PRICE	TOTAL PRICE
1	ODOT 202(D)	2510	UNCLASSIFIED BORROW	CY	100.00		
2	ODOT 501(G)	1800	CLSM BACKFILL	CY	40.60		
3	ODOT 502(B)	3320	(PL) FALSEWORK JACKING	LSUM	1.00		
4	ODOT 504	5140	HANGERS	EA	10.00		
5	ODOT 504(B)	5300	SAW-CUT GROOVING	SY	405.40		
6	ODOT 504(E)	5500	CONCRETE PARAPET	LF	168.00		
7	ODOT 506(A)	7200	STRUCTURAL STEEL	LB	1,100.00		
8	ODOT 507(B)	8310	WEATHERING STL EXP.BEARING ASSEMBLY	EA	10.00		
9	ODOT 509(A)	0210	CLASS AA CONCRETE	CY	119.20		
10	ODOT 509(D)	0510	CLASS C CONCRETE	CY	30.00		
11	ODOT 511	2100	MECHANICAL SPLICES	EA	440.00		
12	ODOT 511(A)	2210	REINFORCING STEEL	LB	2,000.00		
13	ODOT 511(B)	2310	EPOXY COATED REINFORCING STEEL	LB	32,960.00		
14	ODOT 512(A)	3200	PAINTING EXISTING STRUCTURES	LSUM	1.00		
15	ODOT 512(B)	3300	COLLECTION AND HANDLING OF WASTE	LSUM	1.00		
16	ODOT 513(B)	4300	CLASS B BRIDGE DECK REPAIR	SY	116.00		
17	ODOT 513(C)	4400	CLASS C BRIDGE DECK REPAIR	SY	30.00		
18	ODOT 515(A)	7200	WATER REPELLENT (VISUALLY INSPECTED)	SY	644.00		
19	ODOT 517	9110	ELASTOMERIC COATING	SF	1,740.00		
20	ODOT 518(B)	0300	SEALED EXPANSION JOINTS	LF	168.00		
21	ODOT 518(C)	0400	RAPID CURE JOINT SEALANT	LF	167.00		
22	ODOT 520(A)	1200	PREPARATION OF CRACKS, ABOVE WATER	LF	13.00		
23	ODOT 520(C)	1400	EPOXY RESIN, ABOVE WATER	GAL	1.20		
24	ODOT 523(C)	3400	DECK AREA SEALED (FLOODCOATS)	SY	1,618.00		
25	ODOT 535	7100	CORROSION INHIBITOR (SURFACE APPLIED)	SY	124.10		
26	ODOT 540	8112	(PL) REPAIR BRIDGE ITEMS	SY	79.30		
27	ODOT 601(A)	1110	TYPE I PLAIN RIPRAP	TON	1,480.00		
28	ODOT 619(B)	6304	REMOVAL OF BRIDGE ITEMS	LSUM	1.00		
29	ODOT 641	2100	MOBILIZATION	LSUM	1.00		
30	ODOT 642(B)	3300	CONSTRUCTION STAKING LEVEL II	LSUM	1.00		
31	ODOT 856(A)	8204	TRAFFIC STRIPE(MULTI-POLY.)(6" WIDE)	LF	1,260.00		
32	ODOT 858(A)	0260	PAVE.MARKERS CLASS C TYPE 2	EA	6.00		
33	ODOT 877(B)	4300	DELIVER PORTABLE LONGITUDINAL BARRIER	LF	225.00		
34	ODOT 877(C)	4400	RELOCATION OF PORT. LONGITUDINAL BARRIER	LF	675.00		
35	ODOT 880(J)	7110	CONSTRUCTION TRAFFIC CONTROL	LSUM	1.00		

SUBTOTAL BASE BID ITEMS: \$

BASE BID:

\$

TOTAL AMOUNT BASE BID ITEMS IN WORDS:

DOLLARS

Amounts are to be shown in both words and figures. In case of any discrepancy, the amount shown in words will govern.

The above unit prices shall include all costs for labor, materials, overhead, profit, insurance, etc., to cover the finished work of the several kinds called for.

Bidder understands that the Owner reserves the right to reject any or all bids and to waive any informality in the bidding.

The Bidder agrees that this bid shall be good and may not be withdrawn for a period of sixty (60) calendar days after the scheduled closing time for receiving bids.

Upon receipt of written notice of acceptance of this bid, Bidder will execute the formal Contract attached within ten (10) days and deliver all bonds as required by the General Conditions. The bid security attached in the sum of

_____ DOLLARS
(\$ _____) is to become the property of the Owner in the event the Contract and Bonds are not executed within the time set forth above, as liquidated damages for the delay and additional expense to the Owner caused thereby.

RESPECTFULLY SUBMITTED,

By: _____
Title: _____
Address: _____

(AFFIX SEAL-if bid is by a corporation)

BID BOND

(replaces HUD Form 4328-E [2/66, formerly CFA-238-F])

KNOW ALL MEN BY THESE PRESENTS, that we, the undersigned,

_____ as Principal, and
(full name and address)

_____ as Surety is hereby
(full name and address)

held and firmly bound unto the CITY OF LAWTON, as OWNER, in the penal sum of
_____ DOLLARS

(\$_____) for the payment of which, well and truly to be made, we hereby jointly and severally bind ourselves, our heirs, executors, administrators, successors and assigns.

The condition of the above obligation is such that whereas the Principal has submitted to the CITY OF LAWTON a certain bid, attached hereto and whereby made a part hereof to enter into a contract in writing, for the construction of

BRIDGE REHABILITATION
CACHE ROAD OVER WOLF CREEK
PROJECT NO. EN2112

NOW, THEREFORE,

- a. If said bid shall be rejected, or in the alternate,
- b. If said bid shall be accepted and the Principal shall execute and deliver a contract in the Form of Contract attached hereto (properly completed in accordance with said Bid) and shall furnish a bond for his faithful performance of said Contract, and for the payment of all persons performing labor or furnishing materials in connection therewith, and shall in all other respects perform the agreement created by the acceptance of said Bid,

then this obligation (bid bond) shall be void. Otherwise the same shall remain in force and effect. It is expressly understood and agreed that the liability for the Surety for any and all claims hereunder shall, in no event, exceed the penal amount of this obligation as herein stated.

The Surety, for value received, stipulates and agrees that the obligations for said Surety and its bond shall in no way be impaired or affected by an extension of time within which the Owner may accept such Bid. Surety hereby waives notice of any such extension.

IN WITNESS WHEREOF, the Principal and the Surety have hereunto set their hands and seals, and such of them as are corporations have caused their corporate seals to be hereto affixed and these presents to be signed by their proper officers.

Signed this _____ day of _____, 2024

Principal

Surety

(Name of Contractor)

By:

By:

(Name and Title)

(Attorney in Fact) (AFFIX SEAL)

ATTEST:

(Name and Title) (AFFIX SEAL)

ANTICOLLUSION AFFIDAVIT

The following affidavit is submitted by Bidder as a part of this bid and proposal:

**STATE OF OKLAHOMA }
COMANCHE COUNTY }**

The undersigned deponent, of lawful age, being duly sworn, upon his oath, deposes and says that:

- he has lawful authority to execute the within and foregoing proposal;
- he has executed the same by subscribing his name hereto under oath for and on behalf of said bidder;
- bidder has not, directly or indirectly, entered into an agreement; expressed or implied, with any bidder(s) having as its object controlling of the price or amount of such bid(s), the limiting of the bids or the bidders, the parceling or farming out to any bidder(s) or other persons of any part of the contract or any part of the subject matter of the bid(s) or of the profits thereof; and
- he has not and will not divulge the sealed bid to any person whomsoever, except those having a partnership or other financial interest with him in said bid(s) until after the said sealed bid(s) are opened.

Deponent further states that:

- the bidder has not been a party to any collusion among bidders or prospective bidders in any restraint of freedom of competition by agreement to bid at a fixed price, or to refrain from bidding;
- the bidder has not been a party to any collusion with any City official or employee as to quantity, quality, or price in the prospective contract, or any other terms of said prospective contract;
- the bidder has not been in any discussions between bidders and any City official concerning exchange of money or other thing of value for special consideration in the letting of a contract;
- the bidder has not paid, given, or donated or agreed to pay, give, or donate to any officer or employee of the CITY OF LAWTON any money or other thing of value, either directly or indirectly, in the procuring of the award of contract pursuant to this bid.

SIGNED: _____
(Name of Bidder)

BY: _____

Title: _____

Subscribed and sworn to before me this _____ day of _____, 2024.

Notary Public

My Commission Expires: _____

BUSINESS RELATIONSHIPS AFFIDAVIT

STATE OF OKLAHOMA }

COMANCHE COUNTY }

_____, of lawful age, being first duly sworn, on oath says that he is the agent authorized by the bidder to submit the attached bid. Affidavit further states that the nature of any partnership, joint venture, or other business relationship presently in effect or which existed within one (1) year prior to the date of this statement with the architect, engineer, or other party to the project is as follows:

Affiant further states that any such business relationship presently in effect or which existed within one (1) year prior to the date of this statement between any officer or director of the bidding company and any officer or director of the architectural or engineering firm or other party to the project is as follows:

Affiant further states that the names of all persons having any such business relationships and the positions they hold with their respective companies or firms are as follows:

(If none of the business relationships hereinabove mentioned exist, affiant should so state.)

Signed: _____

By: _____

Title: _____

Subscribed and sworn to before me this _____ day of _____, 2024.

Notary Public

My Commission Expires:

EXPERIENCE AND CAPABILITY QUESTIONNAIRE

_____, 2024

The Honorable Mayor and City Council
City of Lawton
212 SW 9th Street
Lawton, Oklahoma 73501

Gentlemen:

**Re: BRIDGE REHABILITATION
CACHE ROAD OVER WOLF CREEK
PROJECT NO. EN2112**

The following information is submitted in answer to the questions listed below:

1. How many years experience as a general contractor have you had in construction similar to the project upon which the attached proposal is submitted?

2. If you have constructed similar projects, list at least three contracts, giving name and location of each project, amount and date of contract, and the owner or agency for whom the work was performed (list only prime contracts).

3. What is the largest project you have ever undertaken as the Prime Contractor? Give location, amount, and date of contract, type of construction, etc.

4. Have you ever failed to complete a contract or been involved in litigation regarding the acceptance of final settlement for work performed? If the answer is "Yes", explain fully.

5. If you are the successful bidder on this project, do you propose to sublet or assign the project or any part thereof to some other contractor?

6. Is your organization an established business, with construction equipment and personnel ready to start work on this project if you are the successful bidder?

7. List all the projects that you have under contract this date, upon which final acceptance has not been made, giving the following information:

CONTRACT NO. 1

Name of Project _____

Owner _____ Location _____

Amount of Contract _____ Date of Contract _____

Time Allowed for Construction _____

Percent of Time Elapsed _____

Percent of Work Actually Accomplished _____

Has there been any litigation? _____

If answer to above question is "Yes", explain fully:

CONTRACT NO. 2

Name of Project _____

Owner _____ Location _____

Amount of Contract _____ Date of Contract _____

Time Allowed for Construction _____

Percent of Time Elapsed _____

Percent of Work Actually Accomplished _____

Has there been any litigation? _____

If answer to above question is "Yes", explain fully:

CONTRACT NO. 3

Name of Project _____

Owner _____ Location _____

Amount of Contract _____ Date of Contract _____

Time Allowed for Construction _____

Percent of Time Elapsed _____

Percent of Work Actually Accomplished _____

Has there been any litigation? _____

If answer to above question is "Yes", explain fully:

CONTRACT NO. 4

Name of Project _____

Owner _____ Location _____

Amount of Contract _____ Date of Contract _____

Time Allowed for Construction _____

Percent of Time Elapsed _____

Percent of Work Actually Accomplished _____

Has there been any litigation? _____

If answer to above question is "Yes", explain fully:

(Attach additional sheets if required)

8. We submit the following list of major construction equipment now owned by us and available for the work that may be awarded, which is in operating condition and good state of repair.

No. Item Type Size or Capacity Present Value

Firm Name

Agent Signature

Title

STATE OF OKLAHOMA }
COUNTY OF COMANCHE }

_____, of legal age, being first duly sworn, upon his oath deposes and says that he executed the above questionnaire on behalf of the Bidder therein named; and that he had lawful authority to do so, and that the information contained therein is true and correct to the best of his knowledge and belief; that he has truthfully answered the questions set forth, and that he has not knowing withheld any information which might affect his status as bidder.

Subscribed and sworn to before me this _____ day of _____, 2024.

Notary Public

My Commission Expires: _____

C O N T R A C T

THIS CONTRACT made and entered into this _____ day of _____, 2024, by and between CITY OF LAWTON, Oklahoma, a Municipal Corporation, acting by and through the Mayor and City Council, party of the first part, hereinafter referred to as "CITY", and _____, party of the second part, hereinafter referred to as "CONTRACTOR".

WHEREAS, the CITY has caused to be prepared in accordance with law, certain Contract Documents and Technical Specifications (including Plans) for the work hereinafter described, and has caused a Solicitation for Bids to be given and advertised as required by law, and has received sealed proposals for the furnishing of all labor and materials for

BRIDGE REHABILITATION
CACHE ROAD OVER WOLF CREEK
PROJECT NO. EN2112

and

WHEREAS, the Contractor in response to said Solicitation for Bids submitted to the CITY in the manner and at the time specified a sealed proposal in accordance with the terms and provisions of said Contract Documents and Technical Specifications, Plans and Addenda(s) associated with this project; and

WHEREAS, the CITY, in the manner provided by law, has publicly opened, examined, and canvassed all the proposals submitted and has determined and declared the above named Contractor to be the best responsive bidder on the above described project; and

WHEREAS, the City, has duly awarded this Contract to said Contractor for the sum specified in the Contractor's proposal, to wit:

_____ Dollars (\$). Said proposal of _____
is incorporated by reference into this contract.

NOW, THEREFORE, for and in consideration of the mutual agreements and covenants herein contained, the parties to this Contract have agreed, and hereby agree, as follows:

1. The Contractor shall, in a good and first-class workmanlike manner, at his own cost and expense, furnish all labor and materials, tools, and equipment required to perform and complete said work in strict accordance with this Contract, the Contract Documents and Technical Specifications and all applicable Plans and Addenda, all of which are on file in the office of the City Engineer, City Hall, Lawton, OK, 73501, and hereby incorporated by reference and made a part of this Contract as if the same were each herein set out at length.
2. The CITY will make progress payments to the Contractor no more than once per month upon request of the Contractor.

Such payment will be made on the basis of an agreed estimate of work performed since the previous pay request, provided that the Contractor and the City Engineer shall have previously come to an agreement as to the amount of the request prior to submission.

The City shall retain five percent (5%) of the amount of each estimate until the project is complete. This retainage shall not be released until final acceptance of project by the City Council.

Each monthly estimate for payment must contain or have attached an affidavit for payment, as set forth in the Contract Documents and Technical Specifications.

On completion of the work, but prior to the acceptance by the CITY, it shall be the duty of the City Engineer, or his authorized designee, to determine that said work has been completed and fully performed in accordance with said Contract Documents and Technical Specifications and all applicable Plans and Addenda; and upon making such determination said official shall make his final certificate to the CITY.

The Contractor hereby agrees to commence work under this Contract on a date to be specified in a written "Work Order" of the CITY and to fully complete the project within **One Hundred Eighty (180) consecutive calendar days**. The Contractor further agrees to pay as liquidated damages, the sum of **Two Thousand Dollars and 00/100 (\$2,000.00) for each consecutive calendar day** thereafter as provided in Paragraph 18 of the General Conditions section of the Contact Documents and Technical Specifications.

The Contractor shall furnish proof that all claims and obligations incurred by him in connection with the performance of said work have been fully paid and settled; said information shall be in the form of an affidavit constituting the Contractor's Release to City as set forth in the Contract Documents and Technical Specifications; thereupon, the final estimate (including any retained amounts) will be approved and paid.

3. Discrimination. The Contractor agrees in connection with the performance of work under this contract as follows:

a. The Contractor will not discriminate against any employee or applicant for employment because of race, creed, color, sex, national origin, disability, or ancestry. Such actions shall include, but not be limited to the following: employment, upgrading, demotion or transfer, recruiting or recruitment, advertising, layoff, termination, rates of pay or other forms of compensation, and selection for training, (including apprenticeship.) The Contractor and subcontractor shall agree to post in a conspicuous place available to employees and applicants for employment, notice to be provided by the City Clerk of the City of Lawton setting forth provisions of this section.

b. The Contractor agrees to include this non-discrimination clause in any subcontracts connected with the performance of this Contract.

c. In the event of the Contractor's non-compliance with the above non-discrimination clause, this Contract may be terminated by the CITY. The Contractor may also be declared by the CITY to be ineligible for future contracts with the CITY until satisfactory proof of intent to comply shall be made by the Contractor.

4. Use of Subcontractors. The Contractor shall actively solicit bids for the subcontracting of goods or services from qualified minority businesses. At the request of the CITY, the Contractor shall furnish evidence of compliance with this requirement of minority solicitation. The Contractor further agrees to consider the grant of subcontracts to minority bidders on the basis of substantially equal proposals in the light most favorable to said minority businesses.

5. Entire Contract. This Contract and all the documents incorporated by reference contain the entire understanding and agreement of the parties upon the subject matter hereof. There is no agreement, oral or otherwise, which is not set forth in writing hereto or attached. This Contract includes the following items: this Contract, the Contract Documents and Technical Specifications, all applicable Plans and Addenda and the Contractor's Proposal.

6. Modification and Termination. This Contract cannot be modified or terminated except in writing signed by both parties or as otherwise provided herein.

7. Assignment. This Contract shall not be assigned without the written consent of the CITY.

8. Bankruptcy. If the Contractor becomes bankrupt or insolvent, or if a petition in bankruptcy is filed against the Contractor, or if a receiver is appointed for the Contractor, the CITY shall have the right to terminate this Contract upon written notice to the Contractor without prejudice to any claim for damages or any other right of the CITY under this Contract to the time of such termination.

9. Variables in Cost. The parties hereto assume and understand that the variables in Contractor's cost of performance may fluctuate; consequently, the parties hereto agree that any fluctuations in Contractor's costs will in no way alter the Contractor's obligations under this Contract nor excuse performance or delay on his part.

10. Venue. This Contract shall be governed by the laws of the State of Oklahoma.

11. This Contract requires proper signature and acceptance by the Contractor and approval by the Lawton City Council before it becomes effective.

IN WITNESS WHEREOF, the parties hereto have caused this instrument to be executed, in three (3) originals, the day and year first above written.

(FOR CORPORATIONS ONLY)

Name of Corporation

By _____

Title _____

ATTEST:

Title _____

(AFFIX SEAL)

(FOR PARTNERSHIPS AND PROPRIETORSHIPS)

Name of Partnership or Proprietorship

By _____

Title _____

COUNTY OF COMANCHE }
STATE OF OKLAHOMA }

Before me the undersigned, a Notary Public in and for said state, on this _____ day of _____, 2024, personally appeared _____, a member of the partnership/proprietorship _____ to me known to be the identical person who executed the within and foregoing instrument on behalf of said partnership/proprietorship and acknowledged to me that _____ (he/she) executed the same as _____ (his/her) free and voluntary act and deed, and for the free and voluntary act and deed of said partnership/proprietorship, for the uses and purposes therein set forth.

Notary Public

My Commission Expires _____

CITY OF LAWTON, OKLAHOMA
A Municipal Corporation

Stan Booker, MAYOR

ATTEST:

Donalynn Blazek-Scherler, CITY CLERK

APPROVED as to form and legality this _____ day of _____, 2024.

John Andrew, CITY ATTORNEY

I, Rebecca Johnson, Interim Finance Director of the City of Lawton, Oklahoma, do hereby certify that I have entered the amount for this encumbrance against appropriate Account No. _____ for _____ (\$ _____), and after charging account title **BRIDGE REHABILITATION CACHE ROAD OVER WOLF CREEK PROJECT NO. EN2112** with this encumbrance there is an unencumbered balance in said account of \$_____.

Dated this _____ day of _____, 2024.

Rebecca Johnson, FINANCE DIRECTOR

PERFORMANCE BOND

KNOW ALL MEN BY THESE PRESENTS that

_____ as Principal, and
(full name and address)

_____ as Surety, a
(full name and address)

corporation organized under the laws of the State of _____, and authorized to transact business in the State of Oklahoma, are hereby held and firmly bound unto the CITY OF LAWTON, as OWNER, in the penal sum

of _____ DOLLARS (\$_____) for the payment of which, well and truly to be made, we hereby jointly and severally bind ourselves, our heirs, executors, administrators, trustees, successors, and assigns, firmly by these presents.

The condition of this obligation is such that WHEREAS, said Principal entered into a written contract with the CITY OF LAWTON, OKLAHOMA, dated on the _____ day of _____, 2024, for

BRIDGE REHABILITATION
CACHE ROAD OVER WOLF CREEK
PROJECT NO. EN2112

all in compliance with the plans and specifications therefore, made a part of said Contract and on file in the Office of the City Clerk, City of Lawton, City Hall, 212 SW 9th St, Lawton, Oklahoma 73501.

NOW, THEREFORE, if said Principal shall

- (1) in all particulars, well, truly and faithfully perform and abide by said Contract, each and every covenant, and part thereof and shall fulfill all obligations resting upon said Principal by the terms of said Contract and said specifications; and
- (2) if said Principal shall promptly pay, or cause to be paid, all labor, materials and/or repairs and all bills for labor performed on said work, whether by subcontract or otherwise.

then this obligation shall be null and void. **Otherwise** said obligation shall be and remain in full force and effect.

It is further expressly agreed and understood by the parties hereto that no changes or alterations in said Contract and no deviations from the plan or mode or procedure herein fixed shall have the effect of releasing the sureties, or any of them, from the obligation of this bond.

IN WITNESS WHEREOF, the said Principal has caused these presents to be executed in its name and its corporate seal to be hereunto affixed by its duly authorized officers, and the said Surety has caused these presents to be executed in its name and its corporate seal to be hereunto affixed by its attorney-in-fact, duly authorized to do so, the day and year above written.

Dated this _____ day of _____, 2024.

Principal:

Surety:

(Name of Contractor)

By: _____
(Name & Title)

By: _____
Attorney-in-Fact (Affix Seal)

(FOR CORPORATIONS ONLY)

ATTEST:

(Name & Title)

(Affix Seal)

(FOR PARTNERSHIPS AND PROPRIETORSHIPS)

Notarized on this _____ day of _____, 2024

Notary: _____ My commission expires: _____

STATUTORY BOND

KNOW ALL MEN BY THESE PRESENTS that

_____ as Principal, and
(full name and address)

_____ as Surety, a
(full name and address)

corporation organized under the laws of the State of _____, and authorized to transact business in the State of Oklahoma, are hereby held and firmly bound unto the CITY OF LAWTON, as OWNER, in the penal sum of

_____ DOLLARS
(\$ _____) in lawful money of the United States of America, for the payment of which, well and truly to be made, we bind ourselves and each of us, our heirs, executors, administrators, trustees, successors, and assigns, jointly and severally, firmly by these presents.

The condition of this obligation is such that WHEREAS, said Principal entered into a written Contract with the CITY OF LAWTON, OKLAHOMA, dated on the _____ day of _____, 2024, for

BRIDGE REHABILITATION
CACHE ROAD OVER WOLF CREEK
PROJECT NO. EN2112

all in compliance with the plans and specifications therefore, made a part of said Contract and on file in the Office of the City Clerk, City Hall, 212 SW 9th St, Lawton, Oklahoma 73501.

NOW, THEREFORE, if said Principal shall fail or neglect to pay all indebtedness incurred by said Principal or subcontractors of said Principal who perform work in the performance of such contract, for labor and materials and repairs to and parts for equipment used and consumed in the performance of said Contract within thirty (30) days after the same becomes due and payable, the person, firm, or corporation entitled thereto may sue and recover on this bond, the amount so due and unpaid. It is further expressly agreed and understood by the parties hereto that no changes or alterations in said Contract and no deviations from the plan or mode of procedure herein fixed shall have the effect of releasing the sureties, or any of them, from the obligations of this bond.

IN WITNESS WHEREOF, said Principal has caused these presents to be executed in its name and its corporate seal to be hereunto affixed by its duly authorized officers, and the said Surety has caused these presents to be executed in its name and its corporate seal to be hereunto affixed by its attorney-in-fact, duly authorized so to do, the year and day first above written.

Dated this _____ day of _____, 2024.

Principal:

Surety:

(Name of Contractor)

By: _____
(Name & Title)

By: _____
Attorney-in-Fact (Affix Seal)

(FOR CORPORATIONS ONLY)

ATTEST:

(Name & Title)

(Affix Seal)

(FOR PARTNERSHIPS AND PROPRIETORSHIPS)

Notarized on this _____ day of _____, 2024

Notary: _____ My commission expires: _____

MAINTENANCE BOND

KNOW ALL MEN BY THESE PRESENTS that

_____ as Principal, and
(full name and address)

_____ as Surety, a
(full name and address)

corporation organized under the laws of the State of _____, and authorized to transact business in the State of Oklahoma, are hereby held and firmly bound unto the CITY OF LAWTON, as OWNER, in the penal sum of

_____ DOLLARS
(\$_____) in lawful money of the United States of America, said sum being equal to One Hundred Percent (100%) of the Contract price, for two (2) years after completion and acceptance of the project, payment of which, well and truly to be made, we bind ourselves and each of us, our heirs, executors, administrators, trustees, successors, and assigns, jointly and severally, firmly by these presents.

The condition of this obligation is such that WHEREAS, said Principal entered into a written contract with the CITY OF LAWTON, OKLAHOMA, dated on the _____ day of _____, 2024, for

BRIDGE REHABILITATION
CACHE ROAD OVER WOLF CREEK
PROJECT NO. EN2112

all in compliance with the plans and specifications therefore, made a part of this contract and file in the Office of the City Clerk of the City of Lawton, City Hall, 212 SW 9th St, Lawton, Oklahoma, 73501.

NOW, THEREFORE, if said Principal shall pay or cause to be paid to the CITY OF LAWTON, OKLAHOMA all damage, loss and expense which may result by reason of defective materials and/or workmanship in connection with said work for a period of TWO (2) years, from and after acceptance of said project by the CITY OF LAWTON and if Principal shall pay or cause to be paid all labor and materials, including the prime contractor and all subcontractors; and if Principal shall save and hold the CITY OF LAWTON harmless from any failure whatsoever of said Principal, then this obligation shall be null and void, otherwise to be and remain in full force and effect.

It is further expressly agreed and understood by the parties hereto that no changes or alterations in said Contract and no deviations from the plan or mode of procedure herein fixed shall have the effect of releasing the sureties, or any of them, from the obligations of the bond.

IN WITNESS WHEREOF, the said Principal has caused these presents to be executed in its name and its corporate seal to be hereunto affixed by its duly authorized officers, and the surety

has caused these presents to be executed in its name and its corporate seal to be hereunto affixed by its attorney-in-fact, duly authorized to do so, the day and year first above written.

Dated this _____ day of _____, 2024.

Principal:

Surety:

(Name of Contractor)

By: _____
(Name & Title)

By: _____
Attorney-in-Fact (Affix Seal)

(FOR CORPORATIONS ONLY)

ATTEST:

(Name & Title) (Affix Seal)

(FOR PARTNERSHIPS AND PROPRIETORSHIPS)

Notarized on this _____ day of _____, 2024

Notary: _____ My commission expires: _____

General Conditions Contents

1. Contract and Contract Documents
2. Definitions
3. Additional Instructions and Detail Drawings
4. Shop or Setting Drawings
5. Materials, Services, and Facilities
6. Contractor's Title to Materials
7. Inspection and Testing of Materials
8. "Or Equal" Clause
9. Patents
10. Surveys, Permits, and Regulations
11. Contractor's Obligations
12. Weather Conditions
13. Protection of Work and Property-(Emergency)
14. Inspection
15. Reports, Records and Data
16. Superintendence by Contractor
17. Extras
18. Time for Completion and Liquidated Damages
19. Correction of Work
20. Subsurface Conditions Found Different
21. Claims for Extra Cost
22. Changes in Work
23. Right of Owner to Terminate Contract
24. Construction Schedule and Periodic Estimates
25. Payments to Contractor
26. Acceptance of Final Payment Constitutes Release
27. Payments by Contractor
28. Insurance
29. Contract Security
30. Additional or Substitute Bond
31. Assignments
32. Mutual Responsibility of Contractors
33. Separate Contracts
34. Subcontracting
35. Engineer's Authority
36. Use of Premises and Removal of Debris
37. Quantities of Estimate
38. Lands and Rights-of-Way
39. General Guaranty
40. Conflicts, Measurements and Discrepancies
41. Notice and Service Thereof
42. Provisions Required by Law Deemed Inserted
43. Protection of Lives and Health
44. Subcontracts
45. Equal Employment Opportunity
46. Prohibited Interests
47. Use and Occupancy Prior to Acceptance by Owner
48. Photographs of Project
49. Suspension of Work
50. Labor Provisions
51. Sales Tax Exemption
52. Special Equal Opportunity Provisions
53. Certification of Compliance Air and Water Acts
54. Employment of Handicap Persons
55. Employment of Females
56. Employment of Veterans

CITY OF LAWTON GENERAL CONDITIONS

1. Contract and Contract Documents

The Plans, Specifications, and Addenda, shall form part of this Contract and the provisions thereof shall be as binding upon the parties hereto as if they were herein fully set forth. The table of contents, titles, headings, running headlines and marginal notes contained herein and in said documents are solely to facilitate reference to various provisions of the Contract Documents and in no way affect, limit or cast light on the interpretation of the provisions to which they refer.

2. Definitions

The following terms as used in this contract are respectively defined as follows:

- a. "Contractor": A person, firm or corporation with whom the contract is made by the Owner.
- b. "Subcontractor": A person, firm or corporation supplying labor and materials or only labor for work at the site of the project for, and under separate contract or agreements with, the Contractor.
- c. "Work on (at) the project": Work to be performed at the location of the project, including the transportation of materials and supplies to or from the location of the project by employees of the Contractor or any Subcontractor.
- d. "Engineer": The term engineer shall apply to the City Engineer or his duly designated representative, to include consultants hired by the Owner to provide advice, assistance or direction concerning the contract.
- e. "Owner": The term Owner shall apply to the City of Lawton, A Municipal Corporation, also referred to as the "CITY."

3. Additional Instructions and Detail Drawings

The Contractor will be furnished additional instructions and detailed drawings as necessary to carry out the work included in the contract. The additional drawings and instructions thus supplied to the Contractor will coordinate with the Contract Documents and will be so prepared that they can be reasonably interpreted as part thereof. The Contractor shall carry out the work in accordance with the additional detail drawings and instructions. The Contractor and the Engineer will prepare jointly: (a) a schedule, fixing the dates at which special detail drawings will be required; such drawings, if any, to be furnished by the Engineer in accordance with said schedule; and (b) a schedule fixing the respective dates for the submission of shop drawings, the beginning of manufacture,

testing and installation of materials, supplies and equipment, and the completion of the various parts of the work; each such schedule to be subject to change from time to time in accordance with the progress of the work.

4. Shop or Setting Drawings

The Contractor shall submit promptly to the Engineer six copies of each shop or setting drawing prepared in accordance with the schedule predetermined as aforesaid. After examination of such drawings by the Engineer and the return thereof, the Contractor shall make such corrections to the drawings as have been indicated and shall furnish the Engineer with two corrected copies. If requested by the Engineer, the Contractor must furnish additional copies. Regardless of corrections made in or approval given to such drawings by the Engineer, the Contractor will nevertheless be responsible for the accuracy of such drawings and for their conformity to the Plans and Specifications, unless he notifies the Engineer in writing of any deviations at the time he furnishes such drawings.

5. Materials, Services, and Facilities

- a. It is understood that except as otherwise specifically stated in the Contract Documents, the Contractor shall provide and pay for all materials, labor, tools, equipment, water, light, power, transportation, superintendence, temporary construction of every nature, and all other services and facilities of every nature whatsoever necessary to execute, complete, and deliver the work within the specified time.
- b. Any work necessary to be performed after regular hours, on Sundays or Legal Holidays, shall be performed without additional expense to the Owner.

6. Contractor's Title to Materials

No materials or supplies for the work shall be purchased by the Contractor or by any Subcontractor subject to any chattel mortgage or under a conditional sale contract, or other agreement by which an interest is retained by the seller. The Contractor warrants that he has good title to all materials and supplies used by him in the work, free from all liens, claims or encumbrances.

7. Inspection and Testing of Materials

- a. All materials and equipment used in the construction of the project shall be subject to adequate inspection and testing in accordance with accepted standards. The laboratory or inspection agency shall be selected by the Owner. The Owner will pay for all laboratory inspection service direct, and not as a part of the contract.
- b. Materials of construction, particularly those upon which the strength and durability of the structure may depend, shall be subject to inspection and testing to establish conformance with specifications and suitability for uses intended.

8. "Or Equal" Clause

Whenever a material, article, or piece of equipment is identified on the plans or in the specifications by reference to manufacturers' or vendors' names, trade names, catalog numbers, etc., it is intended merely to establish a standard. Any material, article, or equipment of other manufacturers and vendors which will perform adequately the duties imposed by the general design will be considered equally acceptable provided the material, article, or equipment so proposed is, in the opinion of the Engineer, of equal substance and function. The proposed substitution shall not be purchased or installed by the contractor without the Engineer's written approval.

9. Patents

- a. The Contractor shall hold and save the Owner and its officers, agents, servants, and employees harmless from liability of any nature or kind, including cost and expenses for, or on account of, any patented or unpatented invention, process, article, or appliance manufactured or used in the performance of the contract, including its use by the Owner, unless otherwise specifically stipulated in the Contract Documents.
- b. License or Royalty Fees. License and/or royalty fees for the use of a process that is authorized by the Owner of the project must be reasonable, and paid to the holder of the patent, or his authorized licensee, direct by the Owner and not by or through the Contractor.
- c. If the Contractor uses any design, device or materials covered by letters, patents or copyrights, he shall provide for such use by suitable agreement with the Owner of such patented or copyrighted design, device or material. It is mutually agreed and understood, that, without exception, the contract prices shall include all royalties or costs arising from the use of such design, device or materials, in any way involved in the work. The Contractor and/or his Sureties shall indemnify and save harmless the Owner of the project from any and all claims for infringement by reason of the use of such patented or copyrighted design, device or materials or any trademark or copyright in connection with work agreed to be performed under this contract, and shall indemnify the Owner for any cost, expense or damage which it may be obliged to pay by reason of such infringement at any time during the prosecution of the work or after completion of the work.

10. Surveys, Permits, and Regulations

- a. Unless otherwise expressly provided for in the Specifications, the Contractor shall be responsible for all surveying and construction staking for the project and the Owner shall furnish to the Contractor all survey control points necessary as indicated in project drawings.
- b. The Contractor shall procure and pay all permits, licenses and approvals necessary for the execution of his contract.

- c. The Contractor shall comply with all laws, ordinances, rules, orders, and regulations relating to performance of the work, the protection of adjacent property, and the maintenance of passageways, guard fences or other protective facilities.

11. Contractor's Obligations

- a. The Contractor shall and will, in good workmanlike manner, do and perform all work and furnish all supplies and materials, machinery, equipment, facilities and means, except as herein otherwise expressly specified, necessary or proper to perform and complete all the work required by this contract, within the time herein specified, in accordance with the provisions of this contract and said specifications and in accordance with the plans and drawings covered by this contract any and all supplemental plans and drawings. He shall furnish, erect, maintain, and remove such construction plant and such temporary works as may be required.
- b. The Contractor shall observe, comply with, and be subject to all terms, conditions, requirements, and limitations of the contract and specifications, and shall do, carry on, and complete the entire work to the satisfaction of the Architect/Engineer and the Owner.

12. Weather Conditions

In the event of suspension of work, or during inclement weather, or whenever the Engineer shall direct, the Contractor will, and will cause his subcontractors to protect carefully his and their work and materials against damage or injury from the weather. If, in the opinion of the Engineer, any work or materials shall have been damaged or injured by reason of failure on the part of the Contractor or any of his Subcontractors so to protect his work, such materials shall be removed and replaced at the expense of the Contractor.

13. Protection of Work and Property- (Emergency)

- a. The Contractor shall at all times safely guard the Owner's property from damage in connection with this contract. He shall at all times safely guard and protect his own work, and that of adjacent property from damage. The Contractor shall replace or make good any such damage, loss or injury unless such be caused directly by errors contained in the contract or by the Owner, or his duly authorized representatives.
- b. In case of emergency which threatens loss or injury of property, and/or safety of life the Contractor will be allowed to act, without previous instructions from the Engineer, in a diligent manner. He shall notify the Engineer immediately thereafter. Any claim for compensation by the Contractor due to such extra work shall be promptly submitted to the Engineer for approval.

- c. Where the Contractor has not taken action but has notified the Engineer of an emergency threatening injury to persons or damage to the work or any adjoining property, he shall act as instructed or authorized by the Engineer.
- d. The amount of reimbursement claimed by the Contractor on account of any emergency action shall be determined in the manner provided in Paragraph 22 of the General Conditions.

14. Inspection

The authorized representatives and agents of the Owner shall be permitted to inspect all work, materials, payrolls, records of personnel, invoices of materials, and other relevant data and records.

15. Reports, Records, and Data

The Contractor shall submit to the Owner such schedule of quantities and costs, progress schedules, payrolls, reports, estimates, records and other data as the Owner may request concerning work performed or to be performed under this Contract.

16. Superintendence by Contractor

At the site of the work, the Contractor shall employ a construction superintendent or foreman who shall have full authority to act for the Contractor. It is understood that such representative shall be one who can be continued in that capacity for the particular job involved unless he ceases to be on the Contractor's payroll.

17. Extras

Without invalidating the contract, the Owner may order extra work or make changes by altering, adding to or deducting from the work, the contract sum being adjusted accordingly, and the consent of the Surety being first obtained where necessary or desirable. All the work of the kind bid upon shall be paid for at the price stipulated in the proposal; and no claims for any extra work or materials shall be allowed unless the work is ordered in writing by the Owner and the price is stated in such order.

18. Time for Completion and Liquidated Damages

- a. It is hereby understood and mutually agreed, by and between the Contractor and the Owner, that the date of beginning and the time for completion as specified in the contract of the work to be done hereunder are **ESSENTIAL CONDITIONS** of this contract; and it is further understood and agreed that the work embraced in this contract shall be commenced on a date to be specified in the "Notice to Proceed".
- b. The Contractor agrees that said work shall be prosecuted regularly, diligently, and uninterruptedly at such rate of progress as will ensure full completion thereof within the time specified. It is expressly understood and agreed, by and between the Contractor and the Owner, that the time for the completion of the work described herein is a reasonable time for the completion of the same; taking into consideration the average climatic range and usual industrial conditions prevailing in this locality.
- c. If the said Contractor shall neglect, fail or refuse to complete the work within the time herein specified, or any proper extension thereof granted by the Owner, then the Contractor hereby agrees, as a part consideration for the awarding of this contract, to pay to the Owner the amount specified in the contract, **not as a penalty but as liquidated damages for such breach of contract** as hereinafter set forth, for each and every consecutive calendar day that the Contractor shall be in default after the time stipulated in the contract for completing the work.
- d. The said amount is fixed and agreed upon by and between the Contractor and the Owner because of the impracticability and extreme difficulty of fixing and ascertaining the actual damages the Owner would in such event sustain; and said amount is agreed to be the amount of the damages which the Owner would sustain and shall be retained from time to time by the Owner from current periodical estimates.
- e. It is agreed that time is of the essence of each and every portion of this contract and of the specifications wherein a definite and certain length of time is fixed for the performance of any act whatsoever. Where, under the contract an additional time is allowed for the completion of any work, the new time limit fixed by such extension shall be of the essence of this contract.
- f. The Contractor shall not be charged with liquidated damages or any excess cost when the Owner determines that the Contractor is without fault and the Contractor's reasons for the time extension are acceptable to the Owner.
- g. The Contractor shall not be charged with liquidated damages or any excess cost when the delay in completion of the work is due to:
 - (1) To any preference, priority, or allocation order duly issued by the Owner;

- (2) To unforeseeable cause beyond the control and without the fault or the negligence of the Contractor, including, but not restricted to, acts of God, or of the public enemy, acts of the Owner, acts of another Contractor in the performance of a contract with the Owner, fires, floods, epidemics, quarantine restrictions, strikes, freight embargoes, and severe weather occurring prior to the original completion date. Except that in the case of severe weather the original completion date as set out in the contract shall be adjusted for severe weather occurring prior to the date originally specified in the contract as the date on which all work pursuant the terms of the contract is to be completed. The revised date, adjusted as described, will be known as the adjusted completion date. There shall be no further adjustment or adjustments to the adjusted completion date, for any reason, once the adjusted completion date has been determined. All conditions of the contract must be satisfied by the Contractor on or before the original completion date or adjusted completion date, which ever is applicable. If all contract requirements have not been met by the original completion date or adjusted completion date, if applicable, liquidated damages, regardless of weather conditions, shall apply for all subsequent days until the actual completion of the contract terms by the contractor.
- (3) To any delays of Subcontractors or suppliers occasioned by any of the causes specified in subsections (1) and (2) of this article;

h. Provided, that the Contractor shall, within ten (10) days from the beginning of delay as set forth in (g) above, unless the Owner shall grant a further period of time prior to the date of final settlement of the contract, notify the Owner, in writing, of the causes of delay. The Owner shall ascertain the facts and extent of the delay and notify the Contractor within a reasonable time of its decision in the matter.

19. Correction of Work

All work, materials, (whether incorporated in the work or not), all processes of manufacture, and all methods of construction shall be at all times and places subject to the inspection of the Engineer who shall be the final judge of the quality and suitability of the work, materials, processes of manufacture, and methods of construction for the purposes for which they are used. Should they fail to meet his approval, they shall be forthwith reconstructed, made good, replaced and/or corrected, as the case may be, by the Contractor at his own expense. Rejected material shall immediately be removed from the site. If, in the opinion of the Engineer, it is undesirable to replace any defective or damaged materials or to reconstruct or correct any portion of the work injured or not performed in accordance with the Contract Documents, payment to be paid to the Contractor hereunder shall be reduced by such amount as in the judgment of the Engineer shall be equitable.

20. Subsurface Conditions Found Different

Should the Contractor encounter subsurface and/or latent conditions at the site materially differing from those shown on the Plans or indicated in the Specifications, he shall immediately give notice to the Engineer of such conditions before they are disturbed. The Engineer will thereupon promptly investigate the conditions, and if he finds that they materially differ from those shown on the Plans or indicated in the Specifications, he will at once make such changes in the Plans and/or Specifications as he may find necessary. Any increase or decrease of cost resulting from such changes shall be adjusted in the manner provided in Paragraph 22 of the General Conditions.

21. Claims for Extra Cost

No claim for extra costs or cost shall be allowed unless the same was done in pursuance of a written order of the Engineer approved by the Owner, as aforesaid, and the claim presented with the first estimate after the changed or extra work is done. When work is performed under the terms of subparagraph 22(b) of the General Conditions, the Contractor shall furnish satisfactory bills, payrolls and vouchers covering all items of cost and when requested by the Owner, give the Owner access to accounts relating thereto.

22. Changes in Work

No changes in the work covered by the approved Contract Documents shall be made without having prior written approval of the Owner. Charges or credits for the work covered by the approved change shall be determined by one or more, or a combination of the following methods:

- a. Unit bid prices previously approved.
- b. The actual cost of:
 - (1) Labor, including foreman,
 - (2) Materials entering permanently into the work,
 - (3) The ownership or rental cost of construction plant and equipment during the time of use on the extra work,
 - (4) Power and consumable supplies for the operation of power equipment,
 - (5) Insurance,
 - (6) Social Security and old age and unemployment contributions.

To the cost under b., there shall be added a fixed fee to be agreed upon but not to exceed fifteen percent (15%) of the actual cost of the work. The fee shall be compensation to cover the cost of supervision, overhead, bond, profit and any other general expenses.

23. Right of Owner to Terminate Contract

In the event that any of the provisions of this contract are violated by the Contractor, or by any of his subcontractors, the Owner may serve written notice upon the Contractor and the Surety of its intention to terminate the contract. Such notices shall contain the reasons for such intention to terminate the contract, and unless within ten (10) days after the serving of such notice upon the Contractor, such violation or delay shall cease and satisfactory arrangement of correction be made, the contract shall, upon the expiration of said ten (10) days, cease and terminate. In the event of any such termination, the Owner shall immediately serve notice thereof upon the Surety and the Contractor; and the Surety shall have the right to take over and perform the contract. If the Surety does not commence performance thereof within ten (10) days from the date of the mailing to such Surety of notice of termination, the Owner may take over the work and prosecute the same to completion by contract at the expense of the Contractor. The Contractor and his Surety shall be liable to the Owner for any excess cost occasioned the Owner thereby; and in such event, the Owner may take possession of and utilize in completing the work, such materials, appliances, and plant as may be on the site of the work and necessary therefore.

24. Construction Schedule and Periodic Estimates

Immediately after execution and delivery of the contract, and before the first partial payment is made, the Contractor shall deliver to the Owner as estimated construction progress schedule in form satisfactory to the Owner, showing the proposed dates of commencement and completion of each of the various subdivisions of work required under the Contract Documents and the anticipated amount of each monthly payment that will become due the Contractor in accordance with the progress schedule. The Contractor shall also furnish on forms to be supplied by the Owner, (a) a detailed estimate giving a complete breakdown of the contract price, and (b) periodic itemized estimates of work done for the purpose of making partial payments thereon. The costs employed in making up any of these schedules will be used only for determining the basis of partial payments and will not be considered as fixing a basis for additions to or deductions from the contract price.

25. Payments to Contractor

- a. At the request of the Contractor and no more than once per month, the Owner shall make a progress payment to the Contractor on the basis of a duly certified and approved estimate of the work performed during the preceding calendar month under this contract. To ensure the proper performance of this contract, the City shall retain 5% of the amount of each estimate. On completion and acceptance of each separate building, public work, or other division of the contract, on which the price is stated separately in the contract, payment may be made in full, including retained percentages thereon, less authorized deductions.
- b. In preparing estimates, the material delivered on the site and preparatory work done may be taken into consideration.

- c. All material and work covered by partial payments made shall thereupon become the sole property of the Owner. This provision shall not be construed as relieving the Contractor from the sole responsibility for the care and protection of materials and work upon which payments have been made or the restoration of any damaged work, or as a waiver of the right of the Owner to require the fulfillment of all the terms of the contract.
- d. The Owner reserves the right to withhold certain amounts and make application thereof. Specifically, the Contractor agrees that he will indemnify and save the Owner harmless from all claims growing out of the lawful demands of subcontractors, laborers, workmen, mechanics, material men, and furnishers of machinery and parts thereof, equipment, power tools, and all supplies, including commissary, incurred in the furtherance of the performance of this contract. The Contractor shall, at the Owner's request, furnish satisfactory evidence that all obligations of the nature hereinabove designated have been paid, discharged, or waived. If the Contractor fails to do so, then the Owner may, after having served written notice on the said Contractor, pay any and all such lawful claims until satisfactory evidence is furnished that all liabilities have been fully discharged whereupon payment to the Contractor shall be resumed, in accordance with the terms of this contract. In no event shall the provisions of this sentence be construed to impose any obligations upon the Owner to either the Contractor or his Surety. In paying any unpaid bills of the Contractor, the Owner shall be deemed the agent of the Contractor, and any payment so made by the Owner shall be considered as a payment made under the contract by the Owner to the Contractor and the Owner shall not be liable to the Contractor for any such payments made in good faith.

26. Acceptance of Final Payment Constitutes Release

The acceptance by the Contractor of final payment shall be and shall operate as a release to the Owner of all claims and all liability to the Contractor for all things done or furnished in connection with this work and for every act and neglect of the Owner and other relating to or arising out of this work. No payment, however, final or otherwise, shall operate to release the Contractor or his sureties from any obligations under this contract or the Performance and Payment Bond.

27. Payments by Contractor

The Contractor shall pay,

- a. for all transportation and utility services not later than the 20th day of the calendar month following that in which services are rendered,
- b. for all materials, tools, and other expendable equipment to the extent of ninety percent (90%) of the cost thereof, not later than the 20th day of the calendar month following that in which said materials, tools, equipment are delivered at the

site of the project, and the balance of the cost thereof, not later than the 30th day following the completion of that part of the work in or on which such materials, tools, and equipment are incorporated or used, and

- c. to each of his subcontractors, not later than the 5th day following each payment to the Contractor the respective amounts allowed the Contractor on account of the work performed by his subcontractors to the extent of each subcontractor's interest therein.

28. Insurance

The Contractor shall not commence work under this contract until he has obtained all the insurance required under this paragraph and such insurance has been approved by the Owner, nor shall the Contractor allow any subcontractor to commence work on his subcontract until the insurance required of the subcontractor has been so obtained and approved.

- a. Worker’s Compensation Insurance. The Contractor shall procure and shall maintain during the life of this contract Worker's Compensation Insurance as required by the State of Oklahoma for all of his employees to be engaged in work at the site of the project under this contract, and in case of any such work sublet, the Contractor shall require the subcontractor similarly to provide Worker's Compensation Insurance for all of the latter’s employees to be engaged in such work unless such employees are covered by the protection afforded by the Contractor's Worker's Compensation Insurance. In case any class of employees engaged in hazardous work on the project under this contract is not protected under the Worker's Compensation Statute, the Contractor shall provide and shall cause each subcontractor to provide adequate employer's liability insurance for the protection of such of his employees as are not otherwise protected.
- b. Contractor's General Liability and Property Damage Insurance and Vehicle Liability Insurance. The Contractor shall procure and shall maintain during the life of this contract, Contractor's General Liability Insurance, Contractor's Property Damage Insurance, and Vehicle Liability Insurance as follows:

Comprehensive General Liability and Bodily Injury:

Bodily Injury	\$ 125,000.00 per person per occurrence
Property Damage	\$ 100,000.00 each occurrence
Combined Single Limit	\$1,000,000.00 per occurrence combined limit

Comprehensive Automobile:

Liability, Bodily Injury	\$125,000.00 per person per occurrence
Property Damage	\$100,000.00 each occurrence
Combined Limit	\$1,000,000.00 per occurrence combined limit

- c. Subcontractor's Public Liability and Property Damage Insurance and Vehicle Liability Insurance. The Contractor shall either,

- (1) require each of his subcontractors to procure, and to maintain during the life of his subcontract, Subcontractor's Public Liability Insurance of the type and in the amounts specified in subparagraph (b) hereof, or
 - (2) ensure the activities of his subcontractors in his own policy, specified in subparagraph (b) hereof.
- d. Scope of Insurance and Special Hazards. The insurance required under subparagraphs b. and c. hereof shall provide adequate protection for the Contractor and his subcontractors, respectively, against damage claims which may arise from operations under this contract, whether such operations be by the insured or by anyone directly or indirectly employed by him, and also against any of the special hazards which may be encountered in the performance of this contract.
- e. Builder's Risk Insurance (Fire and Extended Coverage). Until the project is completed and accepted by the Owner, the Contractor (at the Owner's option) is required to maintain Builder's Risk Insurance (fire and extended coverage) on a one hundred percent (100%) completed value basis on the insurable portion of the project for the benefit of the Owner, the Contractor, and subcontractors as their interests may appear. This provision shall not release the Contractor from his obligation to complete, according to the plans and specifications, the project covered by the contract, and the Contractor and his Surety shall be obligated to full performance of the Contractor's undertaking.
- f. Proof of Carriage of Insurance. The Contractor shall furnish the Owner with certificates showing the type, amount, class of operations covered, effective dates and date of expiration of policies. Such certificates shall also contain substantially the following statement: "The insurance covered by this certification will not be canceled or materially altered, except after ten (10) days written notice has been received by the Owner."

29. Contract Security

The Contractor shall furnish a Performance Bond in an amount at least equal to one hundred percent (100%) of the contract price as security for the faithful performance of this contract and also a Statutory Bond in an amount not less than one hundred percent (100%) of the contract price or in a penal sum not less than that prescribed by State, territorial or local law, as security for the payment of all persons performing labor on the project under this contract and furnishing materials in connection with this contract. The Performance Bond and the Statutory Bond may be in one or in separate instruments in accordance with local law.

30. Additional or Substitute Bond

If at any time the Owner for justifiable cause shall become dissatisfied with any surety or sureties, then upon the Performance or Statutory Bonds, the Contractor shall within five (5) days after notice from the Owner to do so, substitute an acceptable bond (or bonds) in such form and sum and signed by such other surety or sureties as may be satisfactory to the Owner. The premiums on such bond shall be paid by the Contractor. No further payments shall be deemed due nor shall be made until the new surety or sureties shall have furnished such an acceptable bond to the Owner.

31. Assignments

The Contractor shall not assign the whole or any part of this contractor or any moneys due or to become due hereunder without written consent of the Owner. In case the Contractor assigns all or any part of any monies due or to become due under this contract, the instrument of assignment shall contain a clause substantially to the effect that it is agreed that the right of the assignee in and to any monies due or to become due to the Contractor shall be subject to prior claims of all persons, firms and corporations of services rendered or materials supplied for the performance of the work called for in this contract.

32. Mutual Responsibility of Contractors

If, through acts of neglect on the part of the Contractor, any other contractor or any subcontractor shall suffer loss or damage on the work, the Contractor agrees to settle with such other Contractor or subcontractor by agreement or arbitration if such other Contractor or subcontractors will so settle. If such other Contractor or subcontractor shall assert any claim against the Owner on account of any damage alleged to have been sustained, the Owner shall notify the Contractor, who shall indemnify and save harmless the Owner against any such claim.

33. Separate Contract

The Contractor shall coordinate his operations with those of other contractors. Cooperation will be required in the arrangement for the storage of materials and in the detailed execution of the work. The Contractor, including his subcontractors, shall keep informed of the progress and the detail work of other Contractors and shall notify the Engineer immediately of lack of progress or defective workmanship on the part of other Contractors. Failure of a Contractor to keep informed of the work progressing on the site and failure to give notice of lack of progress or defective workmanship by others shall be construed as acceptance by him of the status of the work as being satisfactory for proper coordination with his own work.

34. Subcontracting

- a. The Contractor may utilize the services of specialty subcontractors on those parts of the work that, under normal contracting practices, is performed by specialty subcontractors.

- b. The Contractor shall not award any work to any subcontractor without prior written approval of the Owner. Approval will not be given until the Contractor submits to the Owner a written statement concerning the proposed award to the subcontractor, which statement shall contain such information as the Owner may require.
- c. The Contractor shall be as fully responsible to the Owner for the acts and omissions of his subcontractors, and of persons either directly or indirectly employed by them, as he is for the acts and omissions or persons directly employed by him.
- d. The Contractor shall cause appropriate provisions to be inserted in all subcontracts relative to the work to bind subcontractors to the Contractor by the terms of the General Conditions and other contract documents insofar as applicable to the work of subcontractors and to give the Contractor the same power as regards terminating any subcontract that the Owner may exercise over the Contractor under any provisions of the contract documents.
- e. Nothing contained in this contract shall create any contractual relation between any subcontractor and the Owner.

35. Engineer's Authority

- a. The Engineer shall determine the amount, quality, acceptability, and fitness of the several kinds of work and materials which are to be paid for under this contract and shall decide all questions which may arise in relation to said work and the construction thereof. The Engineer's estimates and decisions shall be final and conclusive, except as herein otherwise expressly provided. In case any question shall arise between the parties hereto relative to said contract or specifications, the determination or decision of the Engineer shall be a condition precedent to the right of the Contractor to receive any money or payment for work under this contract affected in any manner or to any extent by such questions.
- b. The Engineer shall decide the meaning and intent of any portion of the specifications and of any plans or drawings where the same may be found obscure or be in dispute. Any differences or conflicts in regard to their work that may arise between the Contractor under this contract and other contractors performing work for the Owner shall be adjusted and determined by the Engineer. Any work performed on areas which have been identified as obscure or in dispute but for which a determination has not been made by the Engineer, shall be at the sole risk of the Contractor.

36. Use of Premises and Removal of Debris

The Contractor expressly undertakes at his own expense:

- a. to take every precaution against injuries to persons or damage to property;
- b. to store his apparatus, materials, supplies and equipment in such orderly fashion at the site of the work as will not unduly interfere with the progress of his work or the work of any other contractors;
- c. to place upon the work or any part thereof only such loads as are consistent with the safety of that portion of the work;
- d. to frequently clean up all refuse, rubbish, scrap materials, and debris caused by his operations, to the end that at all times the site of the work shall present a neat, orderly and workmanlike appearance;
- e. before final payment to remove all surplus material, false-work, temporary structures, including foundations thereof, plant of any description and debris of every nature resulting from his operations, and to put the site in a neat orderly condition;
- f. to effect all cutting, fitting or patching of his work required to make the same to conform to the plans and specifications and, except with the consent of the Engineer, not to cut or otherwise alter the work of any other Contractor.

37. Quantities of Estimate

Wherever the estimated quantities of work to be done and materials to be furnished under this contract are shown in any of the documents including the proposal, they are given for use in comparing bids and the right is especially reserved as herein otherwise specifically limited, to increase or diminish them as may be deemed reasonably necessary or desirable by the Owner to complete the work contemplated by this contract, and such increase or diminution shall in no way vitiate this contract, nor shall any such increase or diminution give cause for claims or liability for damages.

38. Lands and Rights-of-Way

Prior to the start of construction, the Owner shall obtain all lands and rights-of-way necessary for the carrying out and completion of work to be performed under this contract.

39. General Guaranty

Neither the final certificate of payment nor any provision in the Contract Documents, nor partial or entire occupancy of the premises by the Owner, shall constitute an acceptance of work not done in accordance with the Contract Documents or relieve the Contractor of liability in respect to any express warranties or responsibility for faulty materials or workmanship. The Contractor shall remedy any defects in the work and pay for any

damage to other work resulting therefrom, which shall appear within a period of one year from the date of final acceptance of the work unless a longer period is specified. The Owner will give notice of observed defects with reasonable promptness.

40. Conflicts, Measurements and Discrepancies

- a. Before undertaking each part of the work, the Contractor shall carefully study and compare the Contract Documents and check and verify pertinent figures shown thereon and all applicable field measurements. The Contractor shall promptly report in writing to Engineer any conflict, error or discrepancy which the Contractor may discover and shall obtain a written interpretation or clarification from the Engineer before proceeding with any work affected thereby; however, the Contractor shall not be liable to the Owner or Engineer for failure to report any conflict, error or discrepancy in the Contract Documents, unless the Contractor had actual knowledge thereof or should reasonably have known thereof.
- b. Any work performed which is governed by conflicting details, dimensions, or specifications and is performed without clarification by the Engineer shall be at the sole risk of the Contractor.
- c. No extra charge or compensation in excess of actual quantities required will be allowed because of differences between actual dimensions and the dimensions shown on the drawings.

41. Notice and Service Thereof

Any notice to any Contractor from the Owner relative to any part of this contract shall be in writing and considered delivered and the service thereof completed, when said notice is posted, by certified or registered mail, to the said Contractor at his last given address, or delivered in person to said Contractor or his authorized representative on the work.

42. Provisions Required by Law Deemed Inserted

Each and every provision of law and clause required by law to be inserted in this contract shall be deemed to be inserted herein and the contract shall be read and enforced as though it were included herein. If, through mistake or otherwise any such provision is not inserted or is not correctly inserted, then upon the application of either party the contract shall forthwith be physically amended to make such insertion or correction.

43. Protection of Lives and Health

The Contractor shall exercise proper precaution at all times for the protection of persons and property and shall be responsible for all damages to persons or property, either on or off the site, which occur as a result of his prosecution of the work. The safety provisions of applicable laws and building and health regulations described in Chapter XIII, Bureau

of Labor Standards, Department of Labor, Safety and Health Regulations for Construction, shall be observed and the Contractor shall take or cause to be taken, such additional safety and health measures as the Owner may determine to be reasonably necessary.

44. Subcontracts

The Contractor will insert in any subcontracts, any Federal Labor Standards Provisions which may be contained herein and such other clauses as the Owner and the Department of Housing and Urban Development may, by instructions require, and also a clause requiring the subcontractors to include these clauses in any lower tier subcontracts which they may enter into, together with a clause requiring this insertion in any further subcontracts that may in turn be made.

45. Equal Employment Opportunity

During the performance of this contract, the Contractor agrees as follows:

- a. The Contractor will not discriminate against any employee or applicant for employment because of race, religion, sex, color, disability or national origin. The Contractor will take affirmative action to ensure that applicants are employed and that employees are treated during employment without regard to their race, religion, sex, color or national origin. Such action shall include, but not be limited to the following: employment, upgrading, demotion or transfer, recruitment or recruitment advertising, layoff or termination, rates of pay or other forms of compensation, and selection for training, (including apprenticeship). The Contractor agrees to post in conspicuous places, available to employees and applicants for employment, notices to be provided of this nondiscrimination clause.
- b. The Contractor will, in all solicitations or advertisements for employees placed by or on behalf of the Contractor, state that all qualified applicants will receive consideration for employment without regard to race, religion, sex, color, disability or national origin.
- c. The Contractor will send to each labor union or representative or workers with which he has a collective bargaining agreement or other contract or understanding, a notice to be provided advising the labor union or worker's representative of the Contractor's commitments under Section 202 of Executive Order 11246 of September 24, 1965, and shall post copies of the notice in conspicuous places available to employees and applicants for employment.
- d. The Contractor will comply with all provisions of Executive Order No. 11246 of September 24, 1965, and of the rules, regulations, and relevant orders of the Secretary of Labor.

- e. The Contractor will furnish all information and reports required by Executive Order No. 11246 of September 24, 1965, and by the rules, regulations, and orders of the Secretary of Labor, or pursuant thereto, and will permit access to his books, records, and accounts by the Department of Housing and Urban Development and the Secretary of Labor for purposes of investigation to ascertain compliance with such rules, regulations, and orders.
- f. In the event of the Contractor's noncompliance with the nondiscrimination clauses of this contract or with any of such rules, regulations, or orders, this contract may be terminated or suspended in whole or in part and the Contractor may be declared ineligible for further CITY contracts or Federally-assisted construction contracts, in accordance with procedures authorized in Executive Order No. 11246 of September 24, 1965, and such sanctions may be imposed and remedies invoked as provided in Executive Order No. 11246 or September 24, 1965, or by rule, regulation, or order of the Secretary of Labor, or as otherwise provided by law.
- g. The Contractor will include the provisions of paragraph (a) through (f) in every subcontract or purchase order unless exempted by rules, regulations, or orders of the Secretary of Labor issued pursuant to Section 204 of Executive Order No. 11246 of September 24, 1965, so that such provisions will be binding upon each subcontractor or vendor. The Contractor will take such action with respect to any subcontract or purchase order as the Department of Housing and Urban Development may direct as means of enforcing such provisions including sanctions for noncompliance; provided, however, that in the event the Contractor becomes involved in, or is threatened with, litigation with a subcontractor or vendor as a result of such direction by the Department of Housing and Urban Development, the Contractor may request the United States to enter into such litigation to protect the interests of the United States.

46. Prohibited Interests

No official of the Owner who is authorized in such capacity and on behalf of the Owner to negotiate, make, accept or approve, or to take part in negotiating, making, accepting or approving any architectural, engineering, inspection, construction or material supply contract or any subcontract in connection with the construction of the project, shall become directly or indirectly interested personally in this contract or any part hereof. No officer, employee, architect, attorney, engineer or inspector of or for the Owner who is authorized in such capacity and on behalf of the Owner to exercise any legislative, executive, supervisory or other similar functions in connection with the construction of the project, shall become directly or indirectly interested personally in this contract or in any part thereof, any material supply contract, subcontract, insurance contract, or any other contract pertaining to the project.

47. Use and Occupancy Prior to Acceptance by Owner

The Contractor agrees to the use and occupancy of a portion or unit of the project before formal acceptance by the Owner, provided the Owner:

- a. Secures written consent of the Contractor except in the event, in the opinion of the Engineer, the Contractor is chargeable with unwarranted delay in final clean-up of punch list items or other contract requirements, and
- b. Secures endorsement from the insurance carrier and consent of the surety permitting occupancy of the building or use of the project during the remaining period of construction, or,
- c. When the project consists of more than one building, and one of the buildings is occupied, secures permanent fire and extended coverage insurance, including a permit to complete construction. Consent of the surety must also be obtained.

48. Photographs of the Project

If required by the Owner, the Contractor shall furnish photographs of the project, in the quantities and as described in the Special Provisions.

49. Suspension of Work

Should the Owner be prevented or enjoined from proceeding with work either before or after the start of construction by reason of any litigation or other reason beyond the control of the Owner, the Contractor shall not be entitled to make or assert claim for damage by reason of said delay; but time for completion of the work will be extended to such reasonable time as the Owner may determine will compensate for time lost by such delay with such determination to be set forth in writing.

50. Labor Provisions

a. Minimum Wages

All laborers and mechanics employed upon the work covered by this Contract shall be paid unconditionally and not less often than once each week, and without subsequent deduction or rebate of any account (except such payroll deductions as are made mandatory by law and such other payroll deductions as are permitted by the applicable regulations issued by the Secretary of Labor, United States Department of Labor, pursuant to the Anti-Kickback Act hereinafter identified), the full amount due at time of payment computed at wage rates not less than those contained in the wage determination decision of said Secretary of Labor (a copy of which is attached and herein incorporated by reference), regardless of any contractual relationship which may be alleged to exist between the Contractor or any subcontractor and such laborers and mechanics. All laborers and mechanics employed upon such work shall be paid in cash, except that payment may be by check if the employer provides or secures satisfactory facilities approved by the

Owner for the cashing of the same without cost or expense to the employee. For the purpose of this clause, contributions made or costs reasonably anticipated under Section 1 (b)(2) of the Davis-Bacon Act on behalf of laborers or mechanics are considered wages paid to such laborers or mechanics, subject to the provisions of Section 5.5(a)(1)(iv) of Title 29, Code of Federal Regulations. Also for the purpose of this clause, regular contributions made or costs incurred for more than a weekly period under plans, funds, or programs, but covering the particular weekly period, are deemed to be constructively made or incurred during such weekly period.

b. Underpayment of Wages or Salaries

In case of underpayment of wages by the Contractor or by any subcontractors to laborers or mechanics employed by the Contractor or subcontractor upon the work covered by this Contract, the Owner in addition to such other rights as may be afforded it under this Contractor, shall withhold from the Contractor, out of any payments due the Contractor, so much thereof as the Owner may consider necessary to pay such laborers or mechanics the full amount of wages required by this Contract. The amount so withheld may be disbursed by the Owner, for and on account of the Contractor or the subcontractor (as may be appropriate), to the respective laborers or mechanics to whom the same is due or on their behalf prescribed in the applicable wage determination.

c. Anticipated Costs of Fringe Benefits

If the Contractor does not make payments to a trustee or other third person, he may consider as part of the wages of any laborer or mechanic the amount of any costs reasonably anticipated in providing fringe benefits under a plan or program of a type expressly listed in the wage determination decision of the Secretary of Labor which is part of this Contract; provided, however, the Secretary of Labor has found, upon the written request of the Contractor, that the applicable standards of the Davis-Bacon Act have been met. The Secretary of Labor may require the Contractor to set aside in a separate account assets for the meeting of obligations under the plan or program. A copy of findings made by the Secretary of Labor in respect to fringe benefits being provided by the Contractor must be submitted to the Owner with the first payroll filed by the Contractor subsequent to receipt of the findings.

d. Overtime Compensation Required by Contract Works Hours and Safety Standards Act (76 Stat. 357-360: Title 40 U.S.C., Sections 327-332).

1. Overtime Requirements. No Contractor or subcontractor contracting for any part of the contract work which may require or involve the employment of laborers or mechanics, including watchmen and guards, which he is employed on such work to work in excess of 40 hours in such work week unless such laborer or mechanic receives compensation at a

rate not less than one and one-half times his basic rate of pay for all hours worked in excess of 40 hours in such work week.

2. Violation/Liability for Unpaid Wages Liquidated Damages. In the event of any violation of the clause set forth in paragraph (1), the Contractor and any subcontractor responsible therefor shall be liable to any affected employee for his unpaid wages. In addition, such Contractor and subcontractor shall be liable to the United States for liquidated damages. Such liquidated damages shall be computed with respect to each individual laborer or mechanic employed in violations of the clause set forth in paragraph (1), in the sum of \$10 for each calendar day on which such employee was required or permitted to work in excess of the standard workweek of 40 hours without payment of the overtime wages required by the clause set forth in paragraph (1).
3. Withholding for Liquidated Damages. The Owner shall withhold or cause to be withheld, from any monies payment on account of work performed by the Contractor or subcontractor, such sums as may administratively be determined to be necessary to satisfy any liabilities of such Contractor or subcontractor for liquidated damages as provided the clause set forth in paragraph (2).
4. Subcontracts. The Contractor shall insert in any subcontracts the clauses set forth in paragraphs (1), (2), and (3) of this Section and also a clause requiring the subcontractors to include these clauses in any lower tier subcontracts which they may enter into, together with a clause requiring this insertion in any further subcontracts that may in turn be made.

e. Employment of Apprentices/Trainees

1. Apprentices. Apprentices will be permitted to work at less than the predetermined rate for the work they performed when they are employed and individually registered in a bona fide apprenticeship program registered with the U.S. Department of Labor, Manpower Administration, Bureau of Apprenticeship and Training, or with a State Apprenticeship Agency recognized by the Bureau, or if a person is employed in his first 90 days of probationary employment as an apprentice in such an apprenticeship program, who is not individually registered in the program, but who has been certified by the Bureau of Apprenticeship and Training or a State Apprenticeship Agency (where appropriate) to be eligible for probationary employment as an apprentice. The allowable ratio of apprentices to journeymen in any craft classification shall not be greater than the ratio permitted to the contractor as to his entire work force under the registered program. Any employee listed on a payroll at an apprentice wage rate, who is not a trainee as defined in subdivision (2) of this subparagraph or is not registered or otherwise employed as stated above,

shall be paid the wage rates determined by the Secretary of Labor for the classification of work he actually performed. The Contractor or subcontractor will be required to furnish to the contracting officer or a representative of the Wage-Hour Division of the U.S. Department of Labor written evidence of the registration of his program and apprentices as well as the appropriate ratios and wage rates (expressed in percentages of the journeyman hourly rates), for the areas of construction prior to using any apprentices on the contract work. The wage rate paid apprentices shall be not less than the appropriate percentage of the journeyman's rate contained in the applicable wage determination.

2. Trainees. Except as provided in 29 CFR 5.15, trainees will not be permitted to work at less than the predetermined rate for the work performed unless they are employed pursuant to and individually registered in a program which has received prior approval, evidence by formal certification, by the U.S. Department of Labor, Manpower Administration, Bureau of Apprenticeship and Training. The ratio of trainees to journeymen shall not be greater than permitted under the plan approved by the Bureau of Apprenticeship and Training. Every trainee must be paid at not less than the rate specified in the approved program for his level of progress. Any employee listed on the payroll at a trainee rate who is not registered and participating in a training plan approved by the Bureau of Apprenticeship and Training shall be paid not less than the wage rate determined by the Secretary of Labor for the classification of work he actually performed. The Contractor or subcontractor will be required to furnish the contracting officer or a representative of the Wage-Hour Division of the U.S. Department of Labor written evidence of the certification of his program, the registration of the trainees, and the ratios and wage rates prescribed in that program. In the event the Bureau of Apprenticeship and Training withdraws approval of a training program, the Contractor will no longer be permitted to utilize trainees at less than the applicable predetermined rate for the work performed until an acceptable program is approved.
3. Equal Employment Opportunity. The utilization of apprentices, trainees and journeymen under this part shall be in conformity with the equal employment opportunity requirements of Executive Order 11246, as amended, and 29 CFR Part 30.

f. Employment of Certain Persons Prohibited

No person under the age of sixteen or no person who, at the time, is serving sentence in a penal or correctional institution shall be employed on the work covered by this Contract.

g. Regulations Pursuant to So-Called "Anti-Kickback Act"

The Contractor shall comply with the applicable regulations (a copy of which is attached and herein incorporated by reference) of the Secretary of Labor, United States Department of Labor, made pursuant to the so-called "Anti-Kickback Act" of June 13, 1934 (48 Stat. 948; 62 Stat. 862; Title 18 U.S.C., Section 874; and Title 40 U.S.C., Section 276c), and any amendments or modifications thereof, shall cause appropriate provisions to be inserted in subcontracts to insure compliance therewith by all subcontractors subject thereto, and shall be responsible for the submission of affidavits required by subcontractors thereunder, except as said Secretary of labor may specifically provide for reasonable limitations, variations, tolerances, and exemptions from the requirement thereof.

h. Employment of Laborers or Mechanics Not Listed in Aforesaid Wage Determination Decision

Any class of laborers or mechanics which is not listed in the wage determination and which is to be employed under the Contract will be classified or reclassified comfortably to the wage determination by the Owner, and a report of the action taken shall be submitted by the Owner, through the Secretary of Housing and Urban Development, to the Secretary of Labor, United States Department of Labor. In the event the interested parties cannot agree on the proper classification or reclassification of a particular class of laborers and mechanics to be used, the question accompanied by the recommendation of the Owner shall be referred, through the Secretary of Housing and Urban Development, to the Secretary of Labor for final determination.

i. Fringe Benefits Not Expressed as Hourly Wages Rates

The Owner shall require, whenever the minimum wage rate prescribed in the Contract for a class of laborers or mechanics includes a fringe benefit which is not expressed as an hourly wage rate and the Contractor is obligated to pay cash equivalent of such a fringe benefit, an hourly cash equivalent thereof to be established. In the event the interested parties cannot agree upon a cash equivalent of the fringe benefit, the questions, accompanied by the recommendation of the Owner, shall be referred, through the Secretary of Housing and Urban Development, to the Secretary of Labor for determination.

j. Posting Wage Determination Decisions and Authorized Wage Deductions

The applicable wage poster of the Secretary of Labor, United States Department of Labor, and the applicable wage determination decisions of said Secretary of Labor with respect to the various classification of laborers and mechanics employed and to be employed upon the work covered by this Contract, and a statement showing all deductions, if any, in accordance with the provisions of this Contract, to be made from wages actually earned by persons so employed or to be

employed in such classifications, shall be posted at appropriate conspicuous points at the site of the work.

k. Complaints, Proceedings, or Testimony by Employees

No laborer or mechanic to whom the wage, salary, or other labor standards provisions of this Contract are applicable shall be discharged or in any other manner discriminated against by the Contractor or any subcontractor because such employee has filed any complaint or instituted or caused to be instituted any proceeding or has testified or is about to testify in any proceeding under or relating to the labor standards applicable under this Contractor to his employer.

l. Claims and Disputes Pertaining to Wages

Claims and disputes pertaining to wage rates or to classifications of laborers and mechanics employed upon the work covered by this Contractor shall be promptly reported by the Contractor in writing to the Owner for referral by the latter through the Secretary of Housing and Urban Development to the Secretary of Labor, United States Department of Labor, whose decision shall be final with respect thereto.

m. Questions Concerning Certain Federal Statutes and Regulations

All questions arising under this Contract which relate to the application or interpretation of (a) the aforesaid Anti-Kickback Act, (b) the Contract Work Hours and Safety Standards Act, (c) the aforesaid Davis-Bacon Act, (d) the regulations issued by the Secretary of Labor, United States Department of Labor, pursuant to said Acts, or (e) the labor standards provisions of any other pertinent Federal statute, shall be referred, through the Owner and the Secretary of Housing and Urban Development, to the Secretary of Labor, United States Department of Labor, for said Secretary's appropriate ruling or interpretation which shall be authoritative and may be relied upon for the purposes of this Contract.

n. Payrolls and Basic Payroll Records of Contractor and Subcontractors

The Contractor and each subcontractor shall prepare his payroll on forms satisfactory to and in accordance with instructions to be furnished by the Owner. The Contractor shall submit weekly to the Local Public Agency or Public Body two certified copies of all payrolls of the Contractor and of the subcontractors, it being understood that the Contractor shall be responsible for the submission of copies of payrolls of all subcontractors. Each such payroll shall contain the "Weekly Statement of Compliance" set forth in Section 3.3 of Title 29, Code of Federal Regulations. The payrolls and basic payroll records of the Contractor and each subcontractor covering all laborers and mechanics employed upon the work covered by this Contract shall be maintained during the course of the work and preserved for a period of three (3) years thereafter. Such payroll and basic payroll

records shall contain the name and address of each such employee, his correct classification, rate of pay (including rates of contributions or costs anticipated of the types described in Section 1(b)(2) of the Davis-Bacon Act), daily and weekly number of hours worked, deductions made, and actual wages paid. In addition, whenever the Secretary of Labor has found under Section 5.5(a)(1)(iv) of Title 29, Code of Federal Regulations, that the wages of any laborer or mechanic includes the amount of any costs reasonably anticipated in providing benefits under a plan or program described in Section 1(b)(2)(B) of the Davis Bacon Act, the Contractor or subcontractor shall maintain records which show that the commitment to provide such benefits is enforceable, that the plan or program is financially responsible, and that the plan or program has been communicated in writing to the laborers or mechanics affected, and records which show the costs anticipated or the actual cost incurred in providing such benefits. The Contractor and each subcontractor shall make his employment records with respect to persons employed by him upon the work covered by this Contract available for inspection by authorized representatives of the Secretary of Housing and Urban Development, the Owner, and the United States Department of Labor. Such representative shall be permitted to interview employees of the Contractor or of any subcontractor during working hours on the job.

o. Specific Coverage of Certain Types of Work by Employees

The transporting of materials and supplies to or from the site of the Project to which this Contract pertains by the employees of the Contractor or of any subcontractor, and the manufacturing or furnishing of materials, articles, supplies, or equipment on the site of the Project to which this Contract pertains by persons employed by the Contractor or by any subcontractor, shall, for the purposes of this Contract, and without limiting the generality of the foregoing provisions of this Contract, be deemed to be work to which these, Federal Labor Standards Provisions are applicable.

p. Provisions to be Included in Certain Subcontracts

The Contractor shall include or cause to be included in each subcontract covering any of the work covered by this Contract, provisions which are consistent with any Labor Standards Provisions, included herein and also a clause requiring the subcontractors to include such provisions in any lower tier subcontracts which they may enter into, together with a clause requiring such insertion in any further subcontracts that may in turn be made.

q. Ineligible Subcontractors

The Contractor shall not subcontract any part of the work covered by this Contract or permit subcontracted work to be further subcontracted without the Owner's prior written approval of the subcontractor. The Owner will not approve any subcontractor for work covered by this Contract who is at the time ineligible

under the provisions of any applicable regulations issued by the Secretary of Labor, United States Department of labor or the Secretary of Housing and Urban Development, to receive an award of such subcontract.

1. Breach of Foregoing Federal Labor Standards Provisions

In addition to the clauses for termination of this Contract as herein elsewhere set forth, the Owner reserves the right to terminate this Contract if the Contractor or any subcontractor whose subcontract covers any of the work covered by this Contract shall breach any of these Federal Labor Standards Provisions. A breach of these Federal Labor Standards Provisions may also be grounds for debarment as provided by the applicable regulations issued by the Secretary of Labor, United States Department of Labor.

r. Employment Practices

The Contractor shall, to the greatest extent practicable, follow hiring and employment practices for work on the project that will provide new job opportunities for the unemployed and underemployed. This clause shall be inserted in each construction subcontract.

s. Contract Termination; Debarment

A breach of Section 45 and the Federal Labor Standards Provisions may be grounds for termination of the Contractor, and for debarment as provided in 29 CFR 5.6.

51. Sales Tax Exemption

Pursuant to Oklahoma Statutes, Title 68, 1356(I0), Contractors and Subcontractors shall be exempted from the tax levied on the sale of tangible personal property or services necessary for the completion of this construction contract. Any Contractor or Subcontractor making purchases for this contract on behalf of the City of Lawton shall certify, in writing, on the copy of the invoice or sales ticket to be retained by the vendor, that the purchases are made for and on behalf of the City of Lawton.

Contractors and Subcontractors shall request a written Sales Tax Exemption by contacting the Engineering Department, City of Lawton, at 2202 S.W. 3rd Street, Lawton, Oklahoma, 73501 (580-581-3385) who will issue such exemption on an individual project basis. It shall be the Contractor's and Subcontractor's responsibility to secure the Sales Tax Exemption and failure to do so will not lessen their liability for payment of the sales tax.

Until the City of Lawton accepts the improvements, purchases for carrying out the contract for construction of this project shall be exempt from sales taxes as provided in

the cited statute. Two Tax Commission interpretations of the Oklahoma statutes Title 68 Sec 1356(I0) are listed below to avoid contention among the City of Lawton, its contractors, and the Tax Commission.

"Exemptions apply to materials incorporated into the project, but not to concrete forms nor to other tools"

"The same reasoning precludes exemptions being applied to rental items"

The Contractor shall certify that purchases are made for or are on behalf of the City of Lawton. Persons who make wrongful or erroneous certifications) shall be guilty of a misdemeanor and shall be punished as provided in the statutes.

52. Special Equal Opportunity Provisions

A. Activities and Contracts Not Subject to Executive Order 11246, as Amended.

(Applicable to Federally assisted construction contracts and related subcontracts under \$10,000.)

During the performance of this contract, the Contractor agrees as follows:

- (1) The Contractor shall not discriminate against any employee or applicant for employment because of race, color, religion, sex or national origin. The Contractor shall take affirmative action to ensure that applicants for employment are employed, and that employees are treated during employment without regard to their race, color, religion, sex, or national origin. Such action shall include, but not be limited to the following: employment, upgrading, demotion, or transfer, recruitment or recruitment advertising, layoff or termination, rates of pay or other forms of compensation; and selection of training, including apprenticeship.
- (2) The Contractor shall post in conspicuous places, available to employees and applicants for employment, notices to be provided by Contracting Officer setting forth the provisions of this nondiscrimination clause. The Contractor shall state that all qualified applicants will receive consideration for employment without regard to race, color, religion, sex, or national origin.
- (3) Contractors shall incorporate foregoing requirements in all subcontracts.

B. Contracts Subject to Executive Order 11246, as Amended.

(Applicable to Federally assisted construction contracts and related subcontracts exceeding \$10,000.)

During the performance of this contract, the Contractor agrees as follows:

- (1) The Contractor will not discriminate against any employee or applicant for employment because of race, color, religion, sex, or national origin. The Contractor will take affirmative action to ensure that applicants are employed, and that employees are treated during employment, without regard to their race, color, religion, sex, or national origin. Such action shall include, but not be limited to the following: employment, upgrading, demotion or transfer, recruitment or recruitment advertising; layoff or termination; rates of pay or other forms of compensation; and selection for training, including apprenticeship. The Contractor agrees to post in conspicuous places, available to employees and applicants for employment, notices to be provided by the Contracting Officer setting forth the provisions of this nondiscrimination clause.
- (2) The Contractor will, in all solicitations or advertisements for employees placed by or on behalf of the Contractor, state that all qualified applicants will receive consideration for employment without regard to race, color, religion, sex, or national origin.
- (3) The Contractor shall send to each labor union or representatives of works with which he has a collective bargaining agreement or other contract or understanding, notice to be provided by the Contract Compliance Officer advising the said labor union or worker's representatives of the Contractor's commitment under this section and shall post copies of the notice in conspicuous places available to employees and applicants for employment.
- (4) The Contractor shall comply with all provisions of Executive Order 11246 of September 24, 1965, and the rules, regulations and relevant orders of the Secretary of Labor.
- (5) The Contractor will furnish all information and reports required by Executive Order 11246 of September 24, 1965, and by the rules, regulations, and orders of the Secretary of Labor, or pursuant thereto, and will permit access to his books, records and accounts by the Department and the Secretary of Labor for purposes of investigation to ascertain compliance with such rules, regulations and orders.
- (6) In the event of the Contractor's noncompliance with the nondiscrimination clauses of this contract, or with any of such rules, regulations or orders, this contract may be canceled, terminated or suspended in whole or in part, and the Contractor may be declared ineligible for further Government contracts or federally assisted construction contract procedures authorized in Executive Order 11246, of September 24, 1965, or by rule, regulation, order of the Secretary of Labor, or as otherwise provided by law.

- (7) The Contractor will include the portion of the sentence immediately preceding Paragraph (1) and the provisions of Paragraph (1) through (7) in every subcontract or purchase order unless exempted by rules, regulations or orders of the Secretary of Labor issued pursuant to Section 204 of Executive Order 11246 of September 24, 1965, so that such provisions will be binding upon each subcontractor or vendor. The Contractor will take such action with respect to any subcontract or purchase order as the Department may direct as a means of enforcing such provisions, including sanctions for noncompliance; provided, however, that in the event Contractor becomes involved in, or is threatened with, litigation with a subcontractor or vendor as a result of such direction by the Department, the Contractor may request the United States to enter into such litigation to protect the interest of the United States.

C. "Section 3 Compliance in the Provision of Training, Employment and Business Opportunities.

During the performance of this contract, the contractor agrees as follows:

- (1) The Contractor agrees to comply with the requirements of Section 3 of the Housing and Urban Development Act of 1968 (12 U.S.C. 1701 u.), as amended, the HUD regulations issued pursuant thereto at 24 CFR Part 135, and any applicable rules and orders of HUD issued thereunder.
- (2) The "Section 3 clause" set forth in 24 CFR 135.20(b) shall form part of this contract, as set forth in Paragraph 1 of the General Conditions, "Contract and Contract Documents".
- (3) Contractor shall incorporate the "Section 3 clause" shown below and the foregoing requirements in all subcontracts.

Section 3 Clause as Set Forth in CFR 135.20(b)

- a. The work to be performed under this contract is on a project assisted under a program providing direct Federal financial assistance from the Department of Housing and Urban Development and is subject to the requirements of Section 3 of the Housing and Urban Development Act of 1968, as amended, 12 U.S.C. 1701u. Section 3 requires that to the greatest extent feasible, opportunities for training and employment be given lower income residents of the project area and contracts for work in connection with the project be awarded to business concerns that are located in, or owned in substantial part by persons residing in the area of the project.
- b. The parties to this contract will comply with the provisions of said Section 3 and the regulations issued pursuant thereto by the Secretary of Housing

and Urban Development set forth in 24 CFR 135.20, and all applicable rules and orders of the Department issued thereunder prior to the execution of this contract. The parties to this contract certify and agree that they are under no contractual or other disability that would prevent them from complying with these requirements.

- c. The Contractor will send to each labor organization or representative of workers with whom he has a collective bargaining agreement or other contract or understanding. If any, a notice advising the said labor organization or workers' representative of his commitments under this Section 3 clause and shall post copies of the notice in conspicuous places available to employees and applicants for employment or training.
- d. The Contractor will include this Section 3 clause in every subcontract for work in connection with the project and will, at the direction of the applicant for or recipient of Federal financial assistance, take appropriate action pursuant to the subcontract upon a finding that the subcontractor is in violation of regulations issued by the Secretary of Housing and Urban Development, 24 CFR 135.20. The Contractor will not subcontract with any subcontractor where it has notice or knowledge that the latter has been found in violation of regulations under 24 CFR 135.20 and will not let any subcontract unless the subcontractor has first provided it with a preliminary statement of ability to comply with the requirements of these regulations.
- e. Compliance with the provisions of Section 3, the regulations set forth in 24 CFR 135.20, and all applicable rules and regulations of the Department issued thereunder prior to the execution of the contract shall be a condition of the Federal financial assistance provided to the project, binding upon the applicant or recipient for such assistance. Failure to fulfill these requirements shall subject the applicant or recipient, its contractor and subcontractors, its successors, and assigns to these sanctions specified by the grant or loan agreement or contract through which Federal assistance is provided, and to such sanctions as are specified by 24 CFR 135.20.

53. Certification of Compliance with Air and Water Acts

(Applicable to Federally assisted construction contracts and related subcontracts exceeding \$100,000.)

Compliance with Air and Water Acts

During the performance of this contract, the contractor and all subcontractors shall comply with the requirements of the Clean Air Act, as amended, 42 USC 1857 et. seq., the Federal Water Pollution Control Act, as amended, 33 USC 1251 et. seq., and the

regulations of the Environmental Protection Agency with respect thereto, at 40 CFR Part 14, as amended.

In addition to the foregoing instruments, all nonexempt contractors and subcontractors shall furnish to the Owner, the following:

- (1) A stipulation by the contractor or subcontractor, that any facility to be utilized in the performance of any nonexempt contract or subcontract, is not listed on the List of Violating Facilities issued by the Environmental Protection Agency (EPA) pursuant to 40 CFR 15.20.
- (2) Agreement by the Contractor to comply with all the requirements of Section 114 of the Clean Air Act, as amended (42 USC 1857c-8) and Section 308 of the Federal Water Pollution Control Act, as amended (33 USC 1318) relating to inspection, monitoring, entry reports and information, as well as all other requirements specified in said Section 114 and Section 308, and all requirements specified in said Section 114 and Section 308, and all regulations and guidelines issued thereunder.
- (3) A stipulation that as a condition for the award of the contract, prompt notice will be given of any notification received from the Director, Office of Federal Activities, EPA, indicating that a facility, utilized, or to be utilized for the contract, is under consideration to be listed on the EPA List of Violating Facilities.
- (4) Agreement by the Contractor that he will include, or cause to be included, the criteria and requirements in Paragraph (1) through (4) of this section in every non exempt subcontract and requiring that the Contractor will take such action as the Government may direct as a means of enforcing such provisions.

54. Employment of Handicapped Persons

Where possible, employment of handicapped persons is encouraged.

55. Employment of Female Persons

Where possible, employment of female persons is encouraged.

56. Employment of Veterans

The contractor agrees to provide certification that special consideration with existing applicable collective bargaining agreements and practices, shall be given to the employment on the project of qualified disabled veterans as defined in 38 USC 2011(1), and to qualified Vietnam-Era veterans, as defined in 38 USC 2011(2)(A).

WORK ORDER

TO: _____

From: City of Lawton

Re: BRIDGE REHABILITATION
CACHE ROAD OVER WOLF CREEK
PROJECT NO. EN2112

Date: _____

You are hereby notified that all contract documents have been entered and accepted in relation to the contract entered into on the _____ day of _____, 2024, by and between the City of Lawton and _____ that work may now be commenced in accordance with said contract.

Authorized by:

Effective Date: _____

**AFFIDAVIT FOR PAYMENTS FOR \$25,000 OR MORE
CITY OF LAWTON, OKLAHOMA**

STATE OF OKLAHOMA }
COUNTY OF COMANCHE }

The undersigned (architect, contractor, supplier or engineer), of lawful age, being first duly sworn, on oath says that this invoice or claim is true and correct. Affiant further states that the (work, services or materials) as shown by this invoice or claim have been (completed or supplied) in accordance with the plans, specifications, orders or requests furnished the affiant. Affiant further states that (s)he has made no payment directly or indirectly to any elected official, officer or employee of the State of Oklahoma, any county or local subdivision of the state, of money or any other thing of value to obtain payment.

(Architect, Contractor, Engineer or Supplier)

Subscribed and sworn to before me this _____ day of _____, 2024.

Notary Public

My Commission Expires:

(Engineer)

Subscribed and sworn to before me this _____ day of _____, 2024.

Notary Public

My Commission Expires:

Note: Copy of this Affidavit must be attached to any invoice submitted by an Architect, Contractor, Engineer or Supplier of material for \$25,000 or more.

PAYMENT CERTIFICATE

TO: City of Lawton

**Re: BRIDGE REHABILITATION
CACHE ROAD OVER WOLF CREEK
PROJECT NO. EN2112**

I, _____ of
Name of Authorized Agent and Designation

_____ do hereby affirm that all claims and Company obligations incurred by me or in my behalf in connection with the performance of the above mentioned project have been fully paid and settled.

Authorized Representative

Name of Company

**STATE OF OKLAHOMA }
COUNTY OF COMANCHE }**

BEFORE ME, the undersigned, a Notary Public in and for said County and State, on this ___ day of _____, 2024, personally appeared _____, (name) to me known to be the identical person who signed the name of _____, (corporation/proprietorship/authorized agent name) an Oklahoma corporation, to the within and foregoing instrument as its _____, (president/owner) and acknowledged to me that he executed the same as his free and voluntary act and deed and as the free and voluntary act and deed of said Corporation/Company for uses and purposes therein set forth.

Witness my hand and seal the day and year last above written.

Notary Public

My Commission Expires: _____

CONTRACTOR'S RELEASE TO CITY

TO: City of Lawton

**Re: BRIDGE REHABILITATION
CACHE ROAD OVER WOLF CREEK
PROJECT NO. EN2112**

This is to certify that _____, by acceptance of this final payment, hereby releases the owner, City of Lawton, from all claims and all liabilities to the City of Lawton for all things done or furnished in connection with work on this project and further releases said City of Lawton from liabilities arising from any act of the owner or his agent arising in connection with this project. This release in no way operates to release the contractor or his Surety from any obligations under this contract or the bond tendered pursuant thereto.

Name of Corporation

Authorized Agent

**STATE OF OKLAHOMA }
COUNTY OF COMANCHE }**

BEFORE ME, the undersigned, a Notary Public in and for said County and State, on this ____ day of _____, 2024, personally appeared _____, (name) to me known to be the identical person who signed the name of _____, (business/proprietorship/authorized agent name), an Oklahoma corporation/proprietorship, to the within and foregoing instrument as its _____(president/owner), and acknowledged to me that he executed the same as his free and voluntary act and deed and as the free and voluntary act and deed of said Corporation/ Company for uses and purposes therein set forth.

Witness my hand and seal the day and year last above written.

Notary Public

My Commission Expires: _____

SUBCONTRACTOR’S WAIVER AND RELEASE OF LIEN UPON FINAL PAYMENT

The undersigned subcontractor or material/equipment supplier, in consideration of the final payment in the amount of \$_, hereby waives and releases its lien, and right to claim a lien for labor, services, or materials furnished to _ (contractor) on the job of **BRIDGE REHABILITATION, CACHE ROAD OVER WOLF CREEK, PROJECT NO. EN2112** for the City of Lawton, Comanche County, Oklahoma.

The said subcontractor or material/equipment supplier has been fully satisfied and paid any and all claims for labor and materials/equipment insofar as they pertain to the “Project” in question.

In further consideration of the payment made and set forth, the undersigned certifies that all of its subcontracts or material/equipment suppliers and employees on the project have already been paid and the undersigned agrees to indemnify and hold completely harmless

_____ (contractor) in the event of any claims hereafter made alleging non-payment by such subcontractors or material/equipment suppliers or employees.

Date: _____

Subcontractor/Supplier

By: _____ (Print Name)

_____ (Signature) _____ (Title)

State of _____ County of _____

Subscribed and sworn to before me on this _____ day of _____, 2024

Notary Public My commissions expires: _____

My commission number: _____

WARNING: These specifications shall not be changed or modified in any manner. This is the latest version as of August 24, 2012.

TECHNICAL SPECIFICATIONS

PREPARED BY

ENGINEERING DIVISION, PUBLIC WORKS DEPARTMENT

CITY OF LAWTON

INDEX FOR
TECHNICAL SPECIFICATIONS

**THE FOLLOWING CITY OF LAWTON AND REFERENCED ODOT
STANDARD SPECIFICATIONS ARE APPLICABLE TO THIS PROJECT.**

SECTION 0100	STREET AND DRAINAGE CONSTRUCTION
SECTION 0600	CONSTRUCTION SIGNING, BARRICADES AND LIGHTS
SECTION 0700	SUBMITTALS
SECTION 0800	PROJECT MANAGEMENT

ODOT 2019 STANDARD SPECIFICATIONS

202	EARTHWORK
501	EXCAVATION AND BACKFILL FOR STRUCTURES
502	FORMS, FALSEWORK, AND TEMPORARY WORKS
504	BRIDGE DECKS, APPROACHES, RAILS, AND PARAPETS
506	STRUCTURAL STEEL
507	BEARING ASSEMBLIES
509	STRUCTURAL CONCRETE
511	REINFORCING STEEL FOR STRUCTURES
512	PAINTING
513	REPAIR OF CONCRETE BRIDGE DECKS
515	PENETRATING WATER REPELLENT TREATMENT
517	POST-TENSIONING
518	CONSTRUCTION JOINTS AND EXPANSION DEVICES
520	STRUCTUREAL CONCRETE REPAIR BY SEALING AND INJECTION
523	CONCRETE SURFACE REPAIR BY SEALING
535	SURFACE APPLIED PENETRATING CORROSION INHIBITORS
601	RIPRAP
619	REMOVAL OF BUILDINGS, STRUCTURES, AND OBSTRUCTIONS
641	MOBILIZATION
642	CONSTRUCTION STAKING
856	TRAFFIC STRIPE (MULTI-POLYMER)
858	PAVEMENT MARKERS
877	PORTABLE LONGITUDINAL BARRIER
880	CONSTRUCTION TRAFFIC CONTROL

TECHNICAL SPECIFICATIONS

SECTION 0100

STREET AND DRAINAGE

Sub-Section	Title
0101	Earthwork
0112	Structural Concrete

SECTION 0101

Earthwork

2019

Description

The work covered by this section is as described in Section 202.01 of the Standard Specifications for Highway Construction, Oklahoma Department of Transportation, 2019 Edition, or the latest edition thereof. All grading and related operations shall be included in this section. All excavation is designated as unclassified excavation. All embankment shall be select borrow.

Materials

The materials used in the execution of the work covered by this section shall be as noted in Section 202.02(B) or Section 705.01 of the Standard Specifications for Highway Construction, Oklahoma Department of Transportation, 2019 Edition, or the latest edition thereof. All embankment shall be Select Borrow.

Construction Methods

The construction methods used to execute the work covered by this section shall be in accordance with Section 202.04 of the Standard Specifications for Highway Construction, Oklahoma Department of Transportation, 2019 Edition, or the latest edition thereof.

Measurement and Payment

Method of Measurement: Work included in this section will be measured on a cubic yard basis for the project.

Basis of Payment: Completed and accepted work will be paid for at the contract unit price for:

Earthwork

Cubic Yard

And such payment shall be full compensation for drifting or hauling of excavated material, hauling and placing of borrow material, plowing scarifying, blading, removal of stone and boulders from the roadway, compacting, shaping, clearing all normal inlet and outlet channels to right-of-way lines, and for all labor, tools, equipment, and incidentals necessary to complete the work as specified.

SECTION 0112

Structural Concrete

Description

The scope of work for this section is furnishing and placing of Class "AA" structural concrete as described in Section 509.01 of the Standard Specifications for Highway Construction, Oklahoma Department of Transportation, 2019 Edition, or the latest edition thereof.

Materials

The materials used shall meet the requirements of Section 509.02 of the Standard Specifications for Highway Construction, Oklahoma Department of Transportation, 2019 Edition, or the latest edition thereof.

Construction Methods

The construction methods used in executing the work shall comply with the requirements of Section 509.04 of the Standard Specifications for Highway Construction, Oklahoma Department of Transportation, 2019 Edition, or the latest edition thereof.

Measurement and Payment

The Engineer will measure structural concrete along the neat lines of the structure as shown on the Plans, unless otherwise modified to fit field conditions. The Engineer will not deduct the volume occupied by reinforcing steel, anchors, weep holes, piling, or pipes and ducts less than 8 in [200 mm] in diameter.

The Engineer will measure concrete volumes less than 20 yd³ [15 m³] per structure as Class A Concrete, Small Structures, if included as a pay item.

CLASS AA CONCRETE

Cubic Yard

TECHNICAL SPECIFICATIONS

SECTION 0600

CONSTRUCTION SIGNING, BARRICADES, AND LIGHTS

SECTION 0600

CONSTRUCTION SIGNING, BARRICADES, AND LIGHTS

1.0 Description

The Contractor shall provide the construction signing, barricades, and lights needed to protect the public and as required by the Engineer.

2.0 Materials

Construction signing, barricades, and lights shall conform to the latest edition of the "Manual of Uniform Traffic Control Devices" (MUTCD), the Oklahoma Department of Highways Construction and Maintenance Barricading, or as approved by the Traffic Engineer.

3.0 Execution

- 3.1 Signs, barricades, and lights shall be installed in compliance with the MUTCD. The Contractor shall submit a plan for construction signing at the pre-construction conference for approval by the Engineer.
- 3.2 The Contractor's schedule shall afford maximum possible access to local property owners.
- 3.3 The Contractor will be responsible for the control of traffic within his work area. The Contractor shall furnish and erect all signs, barricades, lights, and other traffic control devices required to control traffic and maintain said devices during the duration of construction unless otherwise directed by the Engineer.
- 3.4 Maintenance of Traffic:
 - A. The Contractor shall provide reasonable access to the affected residents during construction.
 - B. The roadway, while undergoing improvements, shall be kept open to traffic by the Contractor as possible. When so provided on the plans, traffic will be detoured over an approved route. The Contractor shall keep the portion of the project being used by public traffic (through or local) in a condition such that traffic is adequately accommodated. He shall also provide and maintain, in a safe condition, intersections with streets, residential driveways, garages.
- 3.5 Traffic Control Signs. All existing stop signs, yield signs, or other traffic control signs which impede construction shall be removed and relocated as directed by the

Engineer. When reinstalling, the Contractor shall remove existing concrete from sign and reset the sign with new concrete. It shall be the Contractor's responsibility to arrange for prior inspection by the city of all city-owned signs scheduled for removal. If the Contractor fails to notify the City prior to sign removal, it will be assumed such signs were in good condition at the time of removal.

- 3.6 Should the Contractor desire to completely close the roadway within the work area, he shall submit a written request for approval to the Engineer. The request shall contain the date and duration of closing. The Contractor shall coordinate roadway closings with the County and City officials and shall properly notify all agencies operating emergency vehicles. As a minimum, the Contractor shall provide written notice 48 hours in advance of approved closings to the following individuals or agencies:

Chief, Lawton Police Department
Chief, Lawton Fire Department
Public Works Director/City Engineer
All privately owned ambulance companies
Others (list to be provided by Engineering Division)

- 3.7 All signs damaged or lost by the Contractor shall be replaced by him at no cost to the City. Materials shall be approved by the Engineer. All post-mounted signs shall be reset in concrete and at the proper height and location as directed by the Engineer.

4.0 Measurement and Payment

- 4.1 Method of Measurement: Construction signing, barricades, and lights will not be measured for payment.
- 4.2 Basis of Payment: No direct payment for the work described under this section will be made. The Contractor shall bear all expense of maintaining traffic over the section of road undergoing improvement and of constructing and maintaining such approaches, crossing, intersections and other features as may be necessary without direct compensation. Contractor shall include consideration for this item in the bid price for other scheduled items of the contract.

TECHNICAL SPECIFICATIONS

SECTION 0700

SUBMITTALS

SECTION 0700

SUBMITTALS

Description

This section covers the requirements for submittal data for equipment and non-equipment items to be furnished on this project.

General Execution

The Contractor shall submit to the City Engineer, with such promptness as to cause no delay in his own work or in that of any other contractor, five (5) copies of all shop drawings, manufacturer's catalog sheets, brochures, performance charts, diagrams, schedules, and other standard descriptive data required for the work. The City Engineer shall review them with reasonable promptness, making any necessary corrections. If the submittals indicate variances from the requirements of the contract, the Contractor shall make specific mention of such variation in his letter of transmittal in order that, if acceptable, suitable action may be taken for proper adjustment. Otherwise, the Contractor shall not be relieved of the responsibility of executing the work in compliance with the contract even though the submittals have been reviewed.

Form of Submittals

The submittals shall be numbered consecutively and shall present the following data as applicable:

- a) Name of project
- b) Date of submittal
- c) Reference to applicable section of specifications
- d) Applicable Standards
- e) Identification of revisions on re-submittals
- f) Kinds of materials and finishes
- g) All working and erection dimensions and clearances
- h) All arrangement and section views
- i) Connections between functional parts

The Project Engineer may decline to consider any submittal that does not contain complete data on the work and full information on related matters.

Submittal Procedure

The procedure for review of submittals shall be as follows:

- 1) The Contractor shall submit five (5) copies of the submittal to the City Engineer for his approval. The submittal shall be accompanied by a letter of transmittal,

containing the name of the project, the name of the Contractor, the number of the submittals, titles and other requirements.

- 2) When a submittal is satisfactory to the City Engineer, all five (5) copies will be stamped or marked "Approved" or "Approved as Noted", be dated and three (3) copies will be returned to the Contractor by letter.
- 3) Should a submittal be unsatisfactory to the City Engineer, he will stamp thereon "Revise and Resubmit" and will return three (3) copies to the Contractor with the necessary corrections and changes indicated. The Contractor must make such corrections and changes and submit at least five (5) copies of the re-submittal for approval. The Contractor shall review and resubmit as required by the Project Engineer, until acceptance is obtained.
- 4) The Contractor shall allow sufficient time for preliminary review, corrections and resubmission, and final review of all submittals. The Contractor shall allow not less than fourteen (14) days for each review. Submittals critical to job progress, when requested in writing by the Contractor, will be given priority review.

List of Required Submittals

1. List of all subcontractors
2. Product data on service line and fittings, meters and meter boxes.
3. Product data and certifications on Ductile Iron Pipe, or PVC Pipe and fittings and accessories
4. Product data on butterfly or gate valves and valve boxes
5. Product data on tapping valves, sleeves and valve boxes
6. Product data on fire hydrants
7. Data on waterline or sewerline encasement
8. Copies of all test reports
9. Project Construction Schedule
10. Construction Signing and Traffic Control Plan
11. Manufacturer's data on non-woven geotextile fabric
12. Manufacturer's data on separator fabric
13. Manufacturer's data on the type of joint sealer
14. Manufacturer's data on bituminous primer and binder
15. Test reports on the following materials:
 1. Crushed Stone Pipe Bedding
 2. Cover Aggregate and Base Material
 3. Portland Cement Concrete
 4. Asphalt Concrete
16. Product data on drainage structure fittings (i.e., grates, manholes, inlets, etc.)
17. Manufacturer's data on sanitary sewer manhole frame/cover.

TECHNICAL SPECIFICATIONS

SECTION 0800

PROJECT MANAGEMENT

SECTION 0800

PROJECT MANAGEMENT

1.0 Description

This section covers project management -- individual authorities, construction scheduling, payments, inspections, and project signs.

2.0 Authorities, Duties, Responsibilities

2.1 Project Engineer.

All work shall be done to the satisfaction of the Engineer. He shall decide all questions which arise as to quality and acceptability of materials furnished and work performed, rate of progress of the work, interpretation of the plans and specifications, acceptable fulfillment of the contract, compensation, mutual rights between contractors under these specifications and the suspension of work. He shall determine the amount and quality of the work performed and materials furnished and his decisions and estimates shall be final. His estimates, in such event, shall be condition precedent to the right of the Contractor to receive money due under the contract.

2.2 Inspectors.

- A. Inspectors, designated by and acting under the direction of the Owner/Engineer, shall have the authority to inspect all work done and all materials furnished. Such inspection may extend to all or any part of the work and to the preparation, fabrication or manufacture of the materials to be used. He is authorized to call to the attention of the Contractor any failure of the work or materials to conform to the plans, specifications and contract documents. He shall have the authority to reject materials or suspend the work until any situation at issue can be referred to and decided by the Engineer. These inspections are for assurance on behalf of the Owner and do not relieve the Contractor from the responsibility of controlling the quality of work or materials furnished under this contract.
- B. The Inspector is not authorized to revoke, alter or waive any requirements of the plans and specifications. He shall not act as foreman, perform other duties for the Contractor, or interfere with the management of the Contractor's work. Any advice that the Inspector may give the Contractor shall not be construed as binding the Engineer in any way nor waiving any of the terms of the Contract.

- C. If the Contractor refuses to suspend operations on verbal order of the Inspector, a written order will be presented to the Contractor by the Inspector giving the reason for suspension of work. After placing the order in the hand of the man-in-charge, the Inspector shall immediately leave the job. Work performed during the absence of the Inspector will not be accepted nor paid for, and shall be removed and replaced.

2.3 Contractor.

The Contractor shall become familiar with the project conditions. The Contractor is responsible for controlling all aspects of work and construction and the quality of materials and construction on the jobsite according to the Specifications. Quality Assurance inspections by the Engineer and Inspectors, and visits by other representatives of the Owner shall not relieve the Contractor from complying with the requirements of the Contract.

3.0 Project Construction Schedule

- 3.1 Prior to the start of construction, the Contractor shall submit to the City six (6) copies of a project construction schedule and shall not begin work until written approval from the City is received. The project completion schedule shall include anticipated time frames for each activity for each project and shall be of a "time grid diagram" format.
- 3.2 No progress payments will be made without an approved schedule.

4.0 Prosecution of Construction

- 4.1 The Contractor will, unless otherwise approved by the Engineer, conduct construction on this project during normal working hours as defined below:
 - A. Normal workday shall mean normal eight-hour working day.
 - B. Normal workweek shall mean the forty-hour week encompassing the five-eight-hour days, Monday through Friday.
 - C. Holidays to be observed and not to be included into the normal workweek will be:

New Years Day	January 1st
Memorial Day	Observed the last Monday in May
Independence Day	July 4th
Labor Day	1st Monday in September
Thanksgiving Day	4th Thursday in November
Christmas Day	December 25th

- D. Any of the above dates falling on Sunday shall be observed on the following Monday.
- 4.2 All work contemplated to be done which will not be in accordance with the normal hours will require prior approval of the Engineer. Work, which is of necessity performed at times other than normal working hours, will not require prior approval unless construction scheduling can be arranged to prevent such conflict of time requirements. The Engineering Division shall receive a request from the contractor desiring to work weekends by noon on Thursday. If possible, Engineering will approve such work on a case basis and as set forth in Paragraph 4.4.
- 4.3 All work performed other than the normal working hours, whether scheduled or required, will in no way increase the cost to the Owner for the performance of such work.
- 4.4 The Contractor shall reimburse the City for any overtime inspection services performed on this project. Overtime rates shall be time and a half at the hourly wage of the designated City Inspector. For the purpose of this contract, this overtime rate shall be \$21.75/hour. Overtime shall be defined as any work that occurs outside the normal workday, or workweek, described above, for this project.

The City will bill the Contractor for said overtime services. Payment shall be paid to the City no later than 30 days from date of billing.

5.0 Project Signs

- 5.1 This item shall include the construction, painting, erection, maintenance and removal of project signs for the number of signs indicated in the construction documents at the locations specified therein. Upon completion of the project, the signs shall become the property of the Contractor.
- 5.2 The sign shall be constructed from 3/4 inch exterior grade plywood with one smooth side. Paint for the sign shall be a commercial grade exterior paint that will not show signs of fading during the complete construction period. If the sign fades before completion of the project, the Contractor shall repaint the sign to its original quality. Painting of the sign shall be of professional quality equivalent to commercial sign painting. Mounting posts shall be either redwood or pressure treated pine.
- 5.3 Mounting posts shall be buried to the depth indicated on the drawing and hand compacted in 6 inch lifts. The sign shall be attached to the mounting posts with 3 bolts per post. Bolts shall be standard grade, minimum 3/8 inch diameter with flat

washers on both sides, lock washer and double nuts. Bolts shall be spaced on the sign face between lettering so as not to obscure the wording on the sign and shall be as evenly spaced as possible.

5.4 Sign Data:

Project Name: xxx

Funding: _____

Design Engineer:

Name: City of Lawton - Engineering Division

City, State: Lawton, Oklahoma

NOTE: Two (2) project signs will be required for this project. Location for the installation of these signs will be determined by the Engineer.

- 5.5 The project sign(s) shall be in place within 14 calendar days from the date the Owner awards the contract and shall remain in place during the entire construction period. The project sign(s) shall be removed within 14 calendar days after the Owner's acceptance of the project improvements.

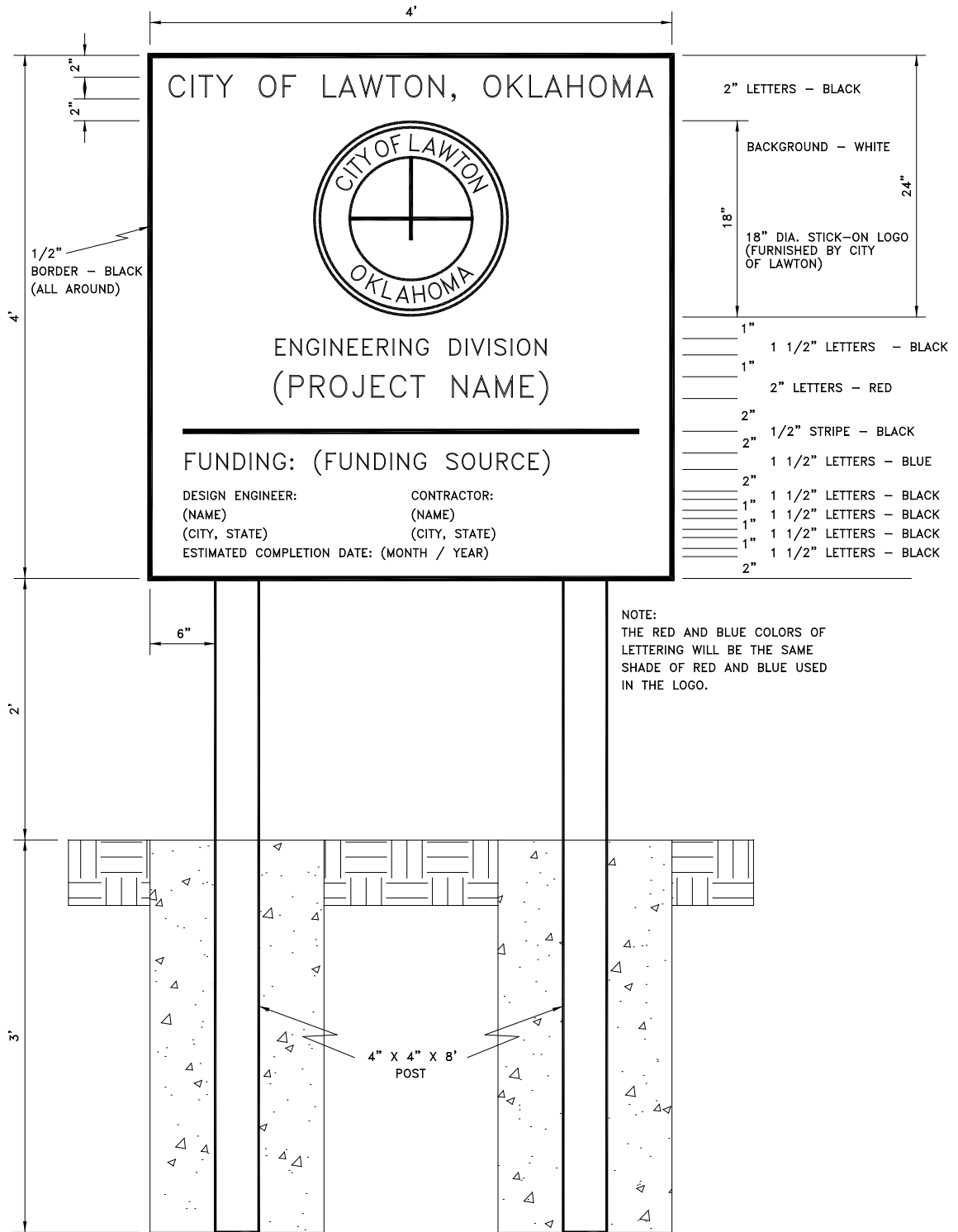

PROJECT SIGNS

6.0 Payment.

Project Management will not be measured for payment. No direct payment for the work described under this section will be made. Contractor shall include consideration for this item in the bid price for other scheduled items of the contract.

SPECIAL PROVISIONS

1. TESTING:

- A. Cost of material testing will be paid by the City, except when tested materials do not meet specifications. Then the cost of such test shall be paid by the Contractor.
- B. The cost of material testing that did not previously meet specifications, but upon re-testing, does meet specifications will be paid by the City.

2. STAKING FOR CONSTRUCTION:

- A. The Contractor will be responsible for layout of the work and will make no changes or relocations without prior written approval of the Engineer. The Contractor shall provide construction grades as required on the plans.
- B. From the base lines and bench marks indicated on the plans or as provided by the Owner, the Contractor shall complete the layout of the work and shall be responsible for all measurements that may be required for the execution of the work to the location and limit marks prescribed in the specifications or on the contract drawings, subject to such modifications as the Engineer may require to meet changed conditions or as a result of necessary modifications to the contract work.

3. BLASTING/BURNING

Blasting or burning will not be permitted on this project.

4. SUB-SURFACE CONDITIONS:

The Contractor shall be responsible for familiarizing himself with surface and sub-surface conditions. The base bid, as shown in the proposal, shall include cost for excavation of rock and backfill with suitable compacted material, dewatering, stabilizing or removal/replacement of unsuitable soils such as quicksand or other unsuitable materials, or any hazard that may be encountered.

5. PLANS AND SPECIFICATIONS FURNISHED:

The Engineer will furnish the Contractor with four (4) sets of plans and specifications at no cost to the Contractor. If additional sets are required, the Contractor will be required to pay the Owner \$25.00 for each additional set.

6. RIGHTS-OF-WAY:

The necessary rights-of-way for the project will be provided by the Owner. The Contractor shall confine his construction operations to the immediate vicinity of the location shown on plans, and shall use due care in placing construction tools, equipment, excavated materials, and supplies, so as to cause the least possible damage to property and interference with traffic. The placing of such tools, equipment and materials shall be subject to the approval of the Engineer.

7. PROTECTION OF PUBLIC AND PRIVATE PROPERTY:

- A.** The Contractor shall not enter any private property outside the designated right-of-way for material delivery or occupy for any other purpose with men, tools, equipment, construction materials or with materials excavated, without written permission from the Owner and Tenant. If it is necessary or desirable that the Contractor use land outside of the right-of-way, the Contractor shall obtain consent from and shall execute a written agreement with the landowner and tenant.
- B.** The Contractor shall protect, shore, brace, support, and maintain all underground pipes, conduits, drains and other underground construction uncovered or otherwise affected by construction work performed by him. All pavement, surfacing, curbs, driveways, and walks affected by construction operations, shall be restored to their original condition as determined and approved by the Engineer. All replacement shall be made with new materials. Property owners will be notified by the City, prior to construction, that it will be the owner's responsibility to remove or relocate fences, trees, shrubs, or other property which they intend to keep. If the items are not removed at the time of construction and are in the way of construction, the Contractor shall remove the items and they shall be stored at the site.
- C.** The Contractor shall take special care not to damage trees not directly interfering with construction, and shall not remove any trees unless authorized by the Engineer. Trees which are to be removed or trees which die because of construction shall be removed by the Contractor and the price shall be included in other pay items.
- D.** The Contractor shall be responsible for all damage to streets, roads, highways, shoulders, ditches, embankments, culverts, bridges and other public or private property, regardless of location or character, which may be caused by transporting equipment, materials or men to or from the work or any part of site thereof, whether by him or his subcontractors. The Contractor shall make satisfactory and acceptable arrangements, with the Owner of, or the Agency or Authority having jurisdiction over, the damaged property concerning its repair or replacement or payment of costs incurred in connection with the damage.

8. UNDERGROUND INSTALLATIONS AND ORDER OF WORK:

- A.** The Contractor shall be responsible for verifying location of utilities (i.e. power poles, gas lines, T.V. lines, buried cables, etc.) public and private *even if not noted on the plans*, by calling 1-800-522-OKIE (1-800-522-6543).
- B.** Existing underground installations such as water mains, gas mains, sewers, telephone lines, power lines, and buried structures in the vicinity of the work to be done hereunder are indicated on the plans only to the extent such information has been made available to or discovered by the Engineer in preparing the plans. This is no guarantee as to the accuracy or completeness of such information, and all responsibility for the accuracy or completeness thereof is expressly disclaimed. Generally, service connections are not indicated on the plans.
- C.** The Contractor shall be solely responsible for locating all existing water and sewer line installations, including service connections in advance of excavating or trenching, by contacting the owners and/or residents. The Contractor shall use his own information and shall not rely upon any information shown on plans concerning existing installations.
- D.** Any delay, additional work or extra cost to the Contractor caused by existing sewer and waterline installations shall not constitute a claim for extra work, additional payment or damages.

9. PROTECTION AND PRESERVATION OF LAND MONUMENTS AND PROPERTY LINE MARKS:

The Contractor shall protect carefully from disturbance or damage all land monuments and iron pins or other markers which establish property or street lines, provided that where such monuments or markers must, of necessity, be disturbed or removed in performance of the contract, the Contractor shall first give ample notice to the Engineer, so that he may witness or reference in such monuments or markers. Should the Contractor disturb, remove or damage any established land monument or property or street line mark without first giving the Engineer ample notice, the Engineer may, at his option, deduct the cost of reestablishing such monuments or marks from any monies due or to become due the Contractor.

10. SANITARY PROVISIONS:

The Contractor shall establish and enforce among his employees such regulations in regard to cleanliness and the disposal of garbage and waste as will tend to prevent the inception and spread of contagious or infectious diseases and to effectively prevent the creation of a nuisance about the work or any property, either public or private; and such regulations as are required by the Engineer shall be put into effect immediately by the

Contractor. The necessary sanitary conveniences for the use of laborers on the work, properly secluded from public observation, shall be constructed and maintained by the Contractor in such manner and at such points as may be approved by the Engineer, and their use shall be strictly enforced by the Contractor. All City, State, and Federal sanitary laws and regulations shall be strictly complied with.

11. POWER:

All power for lighting, operation of Contractor's plant or equipment, or other use by the Contractor, shall be provided by the Contractor at his sole cost and expense.

12. HAZARDS CAUSED BY CONSTRUCTION:

- A. The Contractor shall be held entirely responsible for any and all hazardous conditions whatsoever created or aggravated by the prosecution of the work, and shall exercise every care and take all necessary and prudent precautions and safety measures to prevent injuries or damages to any person or persons or property. The Owner and its officers, agents, or employees will not be responsible for the Contractor's failure to provide the required, necessary, and adequate precautions and provisions to protect persons and property; it shall be entirely the responsibility of the Contractor to ensure that all such precautions have been taken.
- B. It is the Contractor's responsibility to see that work is carried out in a safe manner. The Contractor and his Surety shall indemnify and save harmless the Owner and all its officers, agents, or employees from all suits, actions, or claims of any character, name, and description brought forth on account of any injuries of any character or damages received by any person, persons, or property, by or in consequence or on account of any act or omission, neglect, or use of improper, insufficient, or unsafe methods, materials or equipment in the prosecution of the work.

13. PAY ITEMS - INCIDENTAL CONSTRUCTION:

The Contractor shall be paid only for those items which are listed in the proposal or which are added to the job through a change order. All construction or removal considerations which are not listed as a separate item shall be considered as incidental construction. Cost for these items shall be considered in the most appropriate item listed in the pay quantities.

14. SPECIFICATIONS INCORPORATED BY REFERENCE:

Where other specifications are cited (such as Standard Specifications for Highway Construction; Oklahoma State Department of Transportation, AASHTO, etc.,) then the latest edition of these specifications shall be deemed fully incorporated by reference.

15. SALVAGED MATERIALS:

The Contractor shall carefully remove all salvageable materials. They shall be delivered to the City of Lawton's Public Works Yard. All non-salvageable material shall become the property of the Contractor and shall be properly disposed of by the Contractor. This activity is not a pay item, and work herein is to be included in price bid for other items of work. Determination of materials to be salvaged shall be made by the Engineer. Upon request from the Contractor, waste material from the project may be hauled to the City of Lawton Landfill by the Contractor. The landfill tipping fees will be waived by the City.

16. OMISSIONS:

- A. In the event that the specifications inadvertently omit some of the usual customary work, auxiliary equipment, or material required for satisfactory installation and operation of all equipment, the Contractor shall provide these items as specified by the Engineer at his own expense. The Contractor is assumed to be experienced and qualified in this type of work, and is to furnish materials suitable for the contract.
- B. In the event that the specifications inadvertently fail to contain a specification for work to be done and material to be furnished, then the Standard Current Specification or Requirements of the AWWA, ASTM, ASME, ASEE, NBFU, OSDH, or NEC shall apply. Should the above specifications not apply, then the work done, equipment or material furnished shall be as specified by the Engineer.

17. MATERIALS AND EQUIPMENT SPECIFIED BY TRADE NAME/MANUFACTURER:

Where any equipment or material is referred to or specified by trade name, produced by one manufacturer only, it shall be construed as including any other equipment or material meeting the "Or Equal" clause of the General conditions for this project.

18. PERMITS:

- A. The City is required to comply with all applicable building codes for its construction activities. General Clauses 7, 10, and 35, and Special Provisions 14 and 16 transfer this requirement to the Contractor.

The Contractor will apply for a building permit with the License & Permit Division. The fees for the permit and inspections are waived; such costs will be borne by the City.

In order to verify compliance with the building codes, the License & Permit Division Official will inspect various activities. The results of these code-compliance inspections are subject to approval by the Construction Inspector for contract compliance since the building inspectors are not familiar with specific contract requirements.

In all cases, the most stringent requirements apply. Questions as to specific requirements for the contract should be directed to the Construction Inspector who will resolve conflicts with the building inspectors. The building inspectors are not authorized to relieve the Contractor from the requirements of the contract.

The Contractor should contact the License & Permit Division directly to schedule the appropriate inspections. The Contractor will inform the Construction Inspector of which code-compliance inspections have been requested.

- B.** Permits for placing fill or waste materials at any location within the City limits are required by current City Code. The contractor shall secure such a permit prior to placing any fill or waste within the City limits. Contact the License & Permit Division, City Hall, 212 SW 9th St., Lawton, OK 73501; Ph. (580) 581-3360 for appropriate application forms.
- C.** Any work within a FEMA designated Flood Zone requires the Contractor to obtain a Flood Hazard Permit issued by License & Permit Division located at the address noted in 18.B.

19. WATER USAGE:

The Contractor shall pay for all domestic water (construction office use, etc.) required during the construction project. The Contractor shall pay for all costs including meter deposit and all construction costs required for the installation thereof. Application for water service shall be made to the Revenue Services Division, City Hall, 212 SW 9th Street, Lawton, OK, 73501; Ph (580) 581-3308.

The Contractor shall not pay for water necessary for the construction project such as for grassing, filling and testing of water mains and other construction related uses as approved by the Engineer. The Contractor shall pay a deposit (\$1,580.00) for a construction meter (fire hydrant type) with backflow preventer for water needed for other than domestic usage. This deposit and meter pick-up shall be arranged **first by acquiring a "Permit Letter" from the Fire Department at Central Fire Station, 623 SW 'D' Ave., (580) 581-3280,** and then the Revenue Services Division, City Hall, 212

SW 9th Street, Lawton, Oklahoma; (580) 581-3308. The meter and backflow preventer shall be returned upon completion of the project and a deposit refund made.

20. INDEPENDENT CONTRACTOR STATUS

The Contractor shall accomplish the work according to the terms of this contract as an independent contractor. The contractor agrees to conduct himself in a manner consistent with such status and further agrees that the Contractor, its officials, agents and employees will neither hold themselves out as, or claim to be, an official, agent or employee of the City of Lawton by reason of this agreement.

SPECIAL PROVISIONS TO
THE 2019 ODOT
STANDARD
SPECIFICATIONS

(None Applied)

PLANS

(Sheets 1 - 29)

CITY OF LAWTON

PLANS OF PROPOSED

BRIDGE REHABILITATION PROJECT

CACHE ROAD OVER WOLF CREEK

NBI NUMBER 16541 & 16542; LOCAL ID M09-1 & M09-2

PROJECT EN2112

INDEX OF SHEETS

- 1 TITLE
- 2 SUMMARY OF TRAFFIC PAY QUANTITIES
- 3 GENERAL NOTES - BRIDGE
- 4 SUMMARY OF BRIDGE PAY QUANTITIES
- 5 GENERAL PLAN AND ELEVATION - BRIDGE 'A'
- 6 GENERAL PLAN AND ELEVATION - BRIDGE 'B'
- 7 SUMMARY SHEET
- 8 BRIDGE CONSTRUCTION SEQUENCE
- 9-11 ABUTMENT DETAILS
- 12-14 PIER DETAILS
- 15-22 SUPERSTRUCTURE DETAILS
- 23 RIPAP PLAN
- 24-25 ADVANCED WARNING
- 26-29 SUGGESTED CONSTRUCTION SEQUENCE

LAWTON STANDARDS:
 EROSION CONTROL 1
 EROSION CONTROL 2

THE FOLLOWING ODOT 2019
 STANDARD DRAWINGS WILL BE
 NEEDED:

ROADWAY
 LECS-5-2

THE FOLLOWING ODOT 2009
 STANDARD DRAWINGS WILL BE
 NEEDED:

BRIDGE	TRAFFIC CONTROL
EJ-SQ-04E	TCS1-1-01
EJ-DTL-02E	TCS2-1-00
	TCS3-1-01
	TCS5-1-00
	TCS6-1-02
	TCS7-1-02
	TCS8-1-00
	TCS9-1-01
	TCS11-1-01
	TCS14-1-00
	TCS18-1-01
	TCS19-1-01
	TCS20-1-00
	TCS21-1-02
	TCS22-1-00
	TCS24-1-02

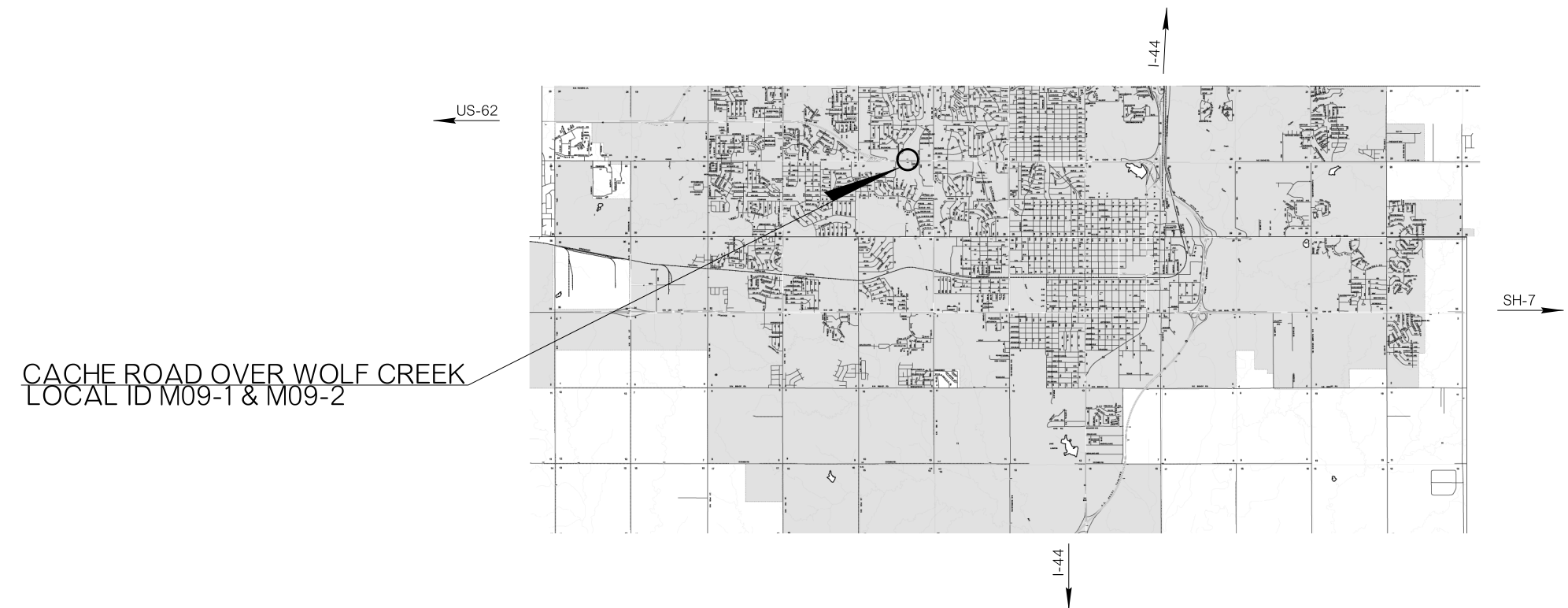

CACHE ROAD OVER WOLF CREEK
 LOCAL ID M09-1 & M09-2

UTILITY STATEMENT

THE UNDERGROUND UTILITIES SHOWN HAVE BEEN LOCATED FROM FIELD SURVEY INFORMATION AND EXISTING DRAWINGS. THE ENGINEER MAKES NO GUARANTEE THAT THE UNDERGROUND UTILITIES SHOWN COMPRISE ALL SUCH UTILITIES IN THE AREA, EITHER IN SERVICE OR ABANDONED. THE ENGINEER FURTHER DOES NOT WARRANT THAT THE UNDERGROUND UTILITIES SHOWN ARE IN THE EXACT LOCATION INDICATED ALTHOUGH HE DOES CERTIFY THAT THEY ARE LOCATED AS ACCURATELY AS POSSIBLE FROM INFORMATION AVAILABLE. THE ENGINEER HAS NOT PHYSICALLY LOCATED THE UNDERGROUND UTILITIES.



THE CONTRACTOR SHALL COORDINATE ALL WORK WITH CITY OF LAWTON PROJECT PU2202. COORDINATION SHALL INCLUDE THE CITY OF LAWTON, ENGINEER AND CONTRACTOR FOR PROJECT PU2202 AND EN2112.

MAYOR
 STAN BOOKER

CITY MANAGER
 JOHN RATLIFF

LAWTON CITY COUNCIL

- WARD 1 - MARY ANN HANKINS
- WARD 2 - KELLY HARRIS
- WARD 3 - LINDA CHAPMAN
- WARD 4 - GEORGE GILL

- WARD 5 - ALLAN HAMPTON
- WARD 6 - DR. ROBERT WEGER
- WARD 7 - SHERENE L. WILLIAMS
- WARD 8 - RANDY WARREN

STAN BOOKER, MAYOR _____ DATE

JOHN RATLIFF, CITY MANAGER _____ DATE

MIKE JONES, INTERIM DIRECTOR OF ENGINEERING _____ DATE



Troy D. Travis _____ 10/18/2024
 TROY D. TRAVIS, P.E. 17004
 OKLAHOMA REGISTERED ENGINEERING FIRM CA 6131
 RESPONSIBLE FOR SHEETS 1-29
 H.W. LOCHNER, INC., 405.748.6651
 6304 WATERFORD BLVD., SUITE 310
 OKLAHOMA CITY, OK 73118

FINAL PLANS

PROJECT DIST NO.	STATE	JEP PROJECT NO.	FISCAL YEAR	SHEET NO.	TOTAL SHEETS
*	OKLA	*****	**		----

PAY ITEM NOTES (TRAFFIC CONSTRUCTION)

- (TC-1) THE CONTRACTOR SHALL FURNISH AND INSTALL SUCH LIGHTS, SIGNS, BARRICADES, AND PROVIDE FLAGGERS NECESSARY FOR THE CONTROL, SAFETY, AND MAINTENANCE OF TRAFFIC WHEN INSTALLING, RELOCATING OR DELIVERING PORTABLE LONGITUDINAL BARRIER.
- (TC-2) QUANTITY INCLUDES SUFFICIENT LENGTH OF PORTABLE LONGITUDINAL BARRIER TO PROVIDE FOR THE LONGEST SECTION SHOWN ON THE PLANS. THIS SAME BARRIER WILL BE USED ON OTHER DETOUR PHASES.
- (TC-13) A PART, OR ALL, OF THIS ITEM IS INTENDED FOR REPLACEMENT OF REMOVED EXISTING CONFLICTING STRIPING.
- (TC-21) INCLUDED IN THE COST OF THIS ITEM SHALL BE INSTALLATION, MAINTENANCE, AND REMOVAL. THIS ITEM SHALL BE BID ACCORDINGLY.
- (TC-26) ALL CONSTRUCTION TRAFFIC CONTROL WILL BE IMPLEMENTED ACCORDING TO CONSTRUCTION PLANS, AND INSTALLED IN A MANNER APPROVED BY THE ENGINEER, IN ACCORDANCE WITH CHAPTER VI OF THE MANUAL ON UNIFORM TRAFFIC CONTROL DEVICES, (CURRENT EDITION), AND COMPLIANT WITH APPLICABLE O.D.O.T. STANDARD DRAWINGS. PRICE BID FOR THIS ITEM SHALL BE PAYMENT IN FULL FOR THE INSTALLATION, MAINTENANCE AND SUBSEQUENT REMOVAL OF ALL NECESSARY CONSTRUCTION TRAFFIC CONTROL DEVICES REQUIRED FOR COMPLETION OF THE PROJECT.

ALL SIGNS AND BARRICADES WHICH ARE SHOWN WITH TYPE 'A' LIGHTS IN THE STANDARD DRAWINGS SHALL HAVE THE CORRESPONDING LIGHT ATTACHED DURING NON-DAYLIGHT HOURS.
- (TC-29) INCLUDED IN THIS ITEM ARE ALL S.C.S. (SPECIAL CONSTRUCTION SIGNING) SIGNS WHICH ARE BETWEEN 6.26 S.F. AND 15.99 S.F. ALSO INCLUDED IN THIS ITEM SHALL BE THE COST OF INSTALLATION, MAINTENANCE, AND REMOVAL OF THESE SIGNS.
- (TC-30) INCLUDED IN THIS ITEM ARE ALL S.C.S. (SPECIAL CONSTRUCTION SIGNING) SIGNS WHICH ARE BETWEEN 16.00 S.F. AND 32.99 S.F. ALSO INCLUDED IN THIS ITEM SHALL BE THE COST OF INSTALLATION, MAINTENANCE, AND REMOVAL OF THESE SIGNS.
- (TC-33) ALL CONSTRUCTION WORK ZONE SIGNS AND CHANNELIZING DEVICES SHALL HAVE FLORESCENT SHEETING. THE FLORESCENT SHEETING SHALL MEET THE REQUIREMENTS OF ASTM 4956-07 FOR TYPE VIII SHEETING.

THE MANUFACTURER SHALL FURNISH A TYPE 'A' CERTIFICATION IN ACCORDANCE WITH O.D.O.T. STANDARD SPECIFICATIONS (CURRENT EDITION) SUBSECTION 106.04. THE CERTIFICATION SHALL INCLUDE TEST RESULTS ON MATERIAL SUBMITTED FOR APPROVAL.
- (TC-52) ANY USED CHANGEABLE MESSAGE SIGN TO BE PLACED ON THIS PROJECT SHALL BE SUBJECT TO INSPECTION AND APPROVAL, BY THE OKLAHOMA DEPARTMENT OF TRANSPORTATION, TO ASSURE THAT THEY ARE IN GOOD WORKING CONDITION, PRIOR TO PLACEMENT ON THE PROJECT.
- (TC-61) ANY DAMAGE TO A FINISHED OR EXISTING SURFACE RESULTING FROM THE CONTRACTORS NEGLIGENCE IN THE REMOVAL OF CONSTRUCTION ZONE PAVEMENT MARKERS OR CHANNELIZING DEVICES AND THE BITUMINOUS ADHESIVE USED IN THEIR INSTALLATION, SHALL BE REPAIRED AT THE CONTRACTOR'S EXPENSE AND TO THE SATISFACTION OF THE ENGINEER.
- (TC-75) TEMPORARY PAVEMENT MARKINGS SHALL BE IN PLACE THE SAME DAY THAT EXISTING PAVEMENT MARKINGS ARE REMOVED FROM ANY ROADWAY OPEN TO TRAFFIC. ALSO, ALL TEMPORARY PAVEMENT MARKINGS SHALL BE REMOVED PRIOR TO THE INSTALLATION OF FINAL STRIPING.
- (TC-84) 180 CONSTRUCTION CALENDAR DAYS WERE USED TO COMPUTE THE SIGN DAY PAY ITEMS. THE AMOUNT OF CALENDAR DAYS USED TO COMPUTE THE SIGN DAY PAY ITEMS IS AND ESTIMATED QUANTITY ONLY, BASED ON THE CURRENT O.D.O.T. STANDARDS AND SUGGESTED CONSTRUCTION SEQUENCE FOR THIS PROJECT. THESE ESTIMATED SIGN DAY QUANTITIES MAY CHANGE AS THE PROJECT'S CONSTRUCTION TRAFFIC CONTROL IS MODIFIED DURING CONSTRUCTION.
- (TC-85) THESE SIGNS MUST BE ON THE OKLAHOMA DEPARTMENT OF TRANSPORTATION LIST OF APPROVED CHANGEABLE MESSAGE SIGNS. FOR A LIST OF THE APPROVED SIGNS GO TO THE OKLAHOMA DEPARTMENT OF TRANSPORTATION WEBSITE AT:
<http://www.okladot.state.ok.us/traffic/qpl/index.php>
- (1) FOR USE ON BRIDGE DECK. ITEM MAY BE REPLACED WITH REMOVABLE PAVEMENT MARKING TAPE AT CONTRACTOR'S EXPENSE.

PAY ITEM NOTES (TRAFFIC STRIPING)

- (TS-25) QUANTITY SHOWN INCLUDES 650 L.F. TRAFFIC STRIPE (MULTI-POLYMER)(WHITE) AND 610 L.F. TRAFFIC STRIPE (MULTI-POLYMER)(YELLOW) AND WILL BE MEASURED BY THE LINEAR FOOT OF SIX INCH (6") WIDE TRAFFIC STRIPE.

PAY QUANTITY NOTES

PAY ITEMS ARE BASED ON ODOT 2019 SPECIFICATIONS

GENERAL CONSTRUCTION NOTES

- 1. PAY ITEMS LISTED IN THE BID SCHEDULE ARE THE ONLY PAY ITEMS FOR THE PROJECT. ANY OTHER ITEMS NECESSARY FOR A COMPLETE PROJECT, BUT NOT SHOWN IN THE BID SCHEDULE SHALL BE CONSIDERED AN INCIDENTAL ITEM AND ITS COST TO BE INCLUDED IN OTHER ITEMS.
- 2. THE CONTRACTOR SHALL VERIFY ALL UTILITY LOCATIONS PRIOR TO BIDDING PROJECT. ALL UTILITY LOCATIONS SHOWN ARE APPROXIMATE, EXCEPT AS NOTED.
- 3. ANY CONTRACTOR-CAUSED DAMAGE TO UTILITY AND/OR SERVICE LINES, SHOWN OR NOT SHOWN ON THE PLANS, SHALL BE REPAIRED OR REPLACED AT NO COST TO THE CITY OF LAWTON AND SHALL BE ACCOMPLISHED BY THE CONTRACTOR, SUBCONTRACTOR OR LICENSED PLUMBER AS APPROVED BY THE CITY ENGINEER.
- 4. THE CONTRACTOR SHALL BE RESPONSIBLE FOR NOTIFYING ALL UTILITY COMPANIES PRIOR TO COMMENCING WORK IN THE PROJECT AREA. LIKEWISE, THE CONTRACTOR IS RESPONSIBLE FOR COORDINATING HIS WORK AND THAT OF THE INVOLVED UTILITIES IN THE PROJECT AREA.
- 5. THE CONTRACTOR SHALL BE RESPONSIBLE FOR FURNISHING ALL LABOR, MATERIAL; EQUIPMENT AND INCIDENTAL ITEMS NEEDED TO PROVIDE ADEQUATE CONSTRUCTION SIGNING, BARRICADES, TRAFFIC CONTROL DEVICES AND OTHER RELATED ITEMS FOR THE PROJECT AREA, DURING THE CONSTRUCTION PERIOD. THIS WORK IS TO BE CONSIDERED AN INCIDENTAL ITEM AND THE COST OF THIS ITEM IS TO BE INCLUDED IN OTHER PAY ITEMS.
- 6. THE CONTRACTOR SHALL NOTIFY THE L.P.D. CHIEF, L.F.D. CHIEF, CITY ENGINEER, PUBLIC WORKS DIRECTOR AND ALL PRIVATELY OWNED AMBULANCE COMPANIES 24 HOURS IN ADVANCE OF WHEN TRAFFIC IS TO BE RESTRICTED ON ANY STREET. IF AN EMERGENCY ARISES, THE CONTRACTOR SHALL IMMEDIATELY NOTIFY ALL PARTIES PREVIOUSLY NOTED.
- 7. THE CONTRACTOR SHALL PROVIDE REASONABLE ACCESS TO RESIDENTIAL, COMMERCIAL AND PUBLIC PROPERTIES IN THE PROJECT AREA. DURING CONSTRUCTION, TRAFFIC MAY BE RESTRICTED TO LOCAL TRAFFIC ONLY WITH APPROVAL OF THE CITY ENGINEER.
- 8. THE CONTRACTOR SHALL CAREFULLY REMOVE, STORE AND REINSTALL ALL CITY-OWNED SIGNS WHOSE REMOVAL IS REQUIRED BY HIS CONSTRUCTION WORK IN THE PROJECT AREA. IT SHALL BE THE CONTRACTOR'S RESPONSIBILITY TO ARRANGE FOR THE CITY TO INSPECT ALL SIGNS SCHEDULED FOR REMOVAL PRIOR TO THEIR REMOVAL. ONCE SAID SIGNS HAVE BEEN REMOVED, IT WILL BE ASSUMED THAT THEY WERE IN GOOD CONDITION AT THE TIME OF REMOVAL. ANY SIGNS DAMAGED OR LOST BY THE CONTRACTOR SHALL BE REPLACED AT NO COST TO THE CITY. MATERIALS SHALL BE APPROVED BY THE CITY ENGINEER.
- 9. ALL POST-MOUNTED SIGNS SHALL BE RESET IN CONCRETE AND AT THE PROPER HEIGHT AND LOCATION (CITY TO PROVIDE LOCATION).
- 10. ALL SIDEWALK AND PAVED DRIVEWAY REMOVALS SHALL BE BOUNDED BY JOINTS OR SAWCUTS IN ACCORDANCE WITH LAWTON STANDARDS.
- 11. THE CONTRACTOR SHALL BE RESPONSIBLE FOR COORDINATING ALL DRIVEWAY CLOSINGS WITH THE RESPECTIVE PROPERTY OWNERS AND TENANTS, IF PROPERTY IS RENTED.
- 12. EXISTING CONCRETE DRIVES WILL BE REPLACED WITH 6" MIN. NON-REINFORCED CLASS 3500 PSI H.E.S. CONCRETE AS SPECIFIED ON THE PLAN DOCUMENTS.
- 13. PROPERTY OWNERS WILL BE NOTIFIED BY THE CITY, PRIOR TO CONSTRUCTION, THAT IT WILL BE THE OWNER'S RESPONSIBILITY TO REMOVE OR RELOCATE FENCES, TREES, SHRUBS OR OTHER PROPERTY WHICH THEY INTEND TO KEEP. IF THE ITEMS ARE NOT REMOVED AT THE TIME OF CONSTRUCTION AND ARE IN THE WAY OF CONSTRUCTION, THE CONTRACTOR SHALL REMOVE AND DISPOSE OF THE ITEMS AS DIRECTED BY THE CITY ENGINEER. FENCES SHALL BE REINSTALLED AT THE CONTRACTOR UNIT PRICE FOR FENCES AS DIRECTED BY THE CITY ENGINEER.
- 14. THE CONTRACTOR SHALL VERIFY ALL DIMENSIONS AND ELEVATIONS PRIOR TO THE START OF WORK.
- 15. ANY SURPLUS EXCAVATION SHALL BECOME THE PROPERTY OF THE CONTRACTOR, AND DISPOSAL SHALL BE THE CONTRACTOR'S RESPONSIBILITY AT NO ADDITIONAL COST.
- 16. THE CONTRACTOR SHALL BE RESPONSIBLE FOR ALL SURVEYING AND CONSTRUCTION STAKING FOR THE PROJECT.
- 17. ALL GRADING AND SURFACING SHALL BE IN ACCORDANCE WITH THE PLAN SHEETS AND OKLAHOMA DEPARTMENT OF TRANSPORTATION STANDARD SPECIFICATIONS FOR HIGHWAY CONSTRUCTION.
- 18. ALL EXCAVATION WITHIN 2' OF PAVEMENT SHALL BE BACKFILLED AND COMPACTED TO 95% STANDARD PROCTOR DENSITY WITH LIMESTONE SCREENINGS.

- 19. THE CONTRACTOR SHALL ESTABLISH A HEALTHY STAND OF BERMUDA GRASS OVER AREAS DISTURBED DURING CONSTRUCTION. THE METHOD OF APPLICATION SHALL BE SOLID SLAB SOD. THE PRICE FOR WATERING AND PROPER MAINTENANCE IS CONSIDERED TO BE INCIDENTAL AND SHALL BE INCLUDED IN THE PRICE BID FOR OTHER ITEMS.
- 20. THE CONTRACTOR SHALL REMOVE AND STOCKPILE ALL SALVAGED TOPSOIL TO BE USED LATER AS BACKFILL BEHIND CURBS AND DRIVES. THIS IS NOT A PAY ITEM, BUT COST OF SAME IS TO BE INCLUDED IN OTHER ITEMS OF WORK.
- 21. THE CONTRACTOR SHALL LEVEL ALL DISTURBED AREAS WITH TOPSOIL AND HAND RAKE TO A UNIFORM APPEARANCE. COST SHALL BE INCLUDED IN THE PRICE BID FOR OTHER ITEMS.
- 22. THE CONTRACTOR SHALL TAKE SPECIAL CARE NOT TO DAMAGE ANY SHEDS OR OTHER STRUCTURES LOCATED ON EXISTING EASEMENTS. SHEDS SHALL NOT BE MOVED UNLESS AUTHORIZED BY THE ENGINEER. ALL COSTS TO REMOVE/REPLACE SHEDS SHALL BE INCLUDED IN THE PRICE BID FOR OTHER ITEMS.
- 23. CAUTION: FOR UNDERGROUND UTILITY LOCATIONS, CONTACT 1-800-522-6543 PRIOR TO EXCAVATION.

PAY QUANTITIES				
0300 TRAFFIC CONTROL				
ITEM NO.	DESCRIPTION		UNIT	TOTAL
858(A) 0260	PAVE MARKERS CLASS C TYPE 2	(1)(TC-21)	EA	6.00
877(B) 4300	DELIVER PORTABLE LONGITUDINAL BARRIER	(TC-1,2)	LF	225.00
877(C) 4400	RELOCATION OF PORT. LONGITUDINAL BARRIER	(TC-1)	LF	675.00
880(J) 7110	CONSTRUCTION TRAFFIC CONTROL	(TC-21,26,29,33)	LSUM	1.00

PAY QUANTITIES				
0301 STRIPING				
ITEM NO.	DESCRIPTION		UNIT	TOTAL
856(A) 8204	TRAFFIC STRIPE(MULTI-POLY)(6" WIDE)	(TC-13)(TS-25)	LF	1,260.00

PAY QUANTITY NOTES

PAY ITEMS ARE BASED ON ODOT 2019 SPECIFICATIONS

THE CONTRACTOR SHALL COORDINATE ALL WORK WITH CITY OF LAWTON PROJECT PU2202. COORDINATION SHALL INCLUDE THE CITY OF LAWTON, ENGINEER AND CONTRACTOR FOR PROJECT PU2202 AND EN2112.

Design		CACHE ROAD OVER WOLF CREEK BRIDGES 'A' AND 'B' SUMMARY OF TRAFFIC PAY QUANTITIES City Project <u>EN2112</u> Sheet No. <u>2</u>
Drawn		
Checked		
Approved		
Squad		

PROJECT DIST NO.	STATE	JEP PROJ NO.	FISCAL YEAR	SHEET NO.	TOTAL SHEETS
*	OKLA	*****	**		----

GENERAL NOTES

SPECIFICATIONS -

COMPLY WITH THE REQUIREMENTS OF THE 2019 OKLAHOMA STANDARD SPECIFICATIONS FOR HIGHWAY CONSTRUCTION, EXCEPT AS MODIFIED BY THE PLANS AND SPECIAL PROVISIONS.

DESCRIPTION OF WORK -

THE WORK TO BE PERFORMED CONSISTS OF REPLACING ALL BRIDGE DECK JOINTS AND SELECT BEARING ASSEMBLIES. FULL DEPTH BRIDGE DECK REPAIRS WILL BE NEEDED. A FLOODCOAT WILL BE APPLIED TO THE BRIDGE DECK AND APPROACH SLABS. SUBSTRUCTURE REPAIRS INCLUDE PNEUMATIC MORTAR OR CLASS AA CONCRETE REPAIR OF THE ABUTMENTS AND PIERS; ELASTOMERIC COATING ON ABUTMENT SEATS AND PIER CAPS; AND FILLING VOIDS UNDER THE ABUTMENT SEATS. RIPRAP WILL BE PLACED ALONG THE EXISTING GROUND AROUND THE ABUTMENTS.

VERIFICATION OF EXISTING CONDITIONS -

THE CONTRACTOR IS RESPONSIBLE FOR FULLY UNDERSTANDING THE NATURE OF THE WORK AND CONDITIONS UNDER WHICH THE WORK WILL BE PERFORMED.

ALL DIMENSIONS AND ELEVATIONS OF THE EXISTING BRIDGE COMPONENTS SHOWN ON THE PLANS ARE APPROXIMATE. THE CONTRACTOR WILL VERIFY ALL DIMENSIONS AND ELEVATIONS NECESSARY TO CONNECT THE NEW MATERIAL AND WILL BE SOLELY RESPONSIBLE FOR THE ACCURACY THEREOF.

USE METHODS CONSISTENT WITH GOOD CONSTRUCTION PRACTICE AND TAKE ALL NECESSARY PRECAUTIONS TO PREVENT DAMAGE TO THE EXISTING BRIDGE AND ATTACHMENTS. ANY DAMAGE TO THE EXISTING BRIDGE STRUCTURE OR ROADWAY DUE TO THE CONTRACTOR'S NEGLIGENCE WILL BE REPAIRED, AT THE CONTRACTOR'S EXPENSE, TO THE SATISFACTION OF THE ENGINEER.

EXISTING PLANS -

CONSTRUCTION PLANS FOR THE EXISTING STRUCTURE(S) MAY BE OBTAINED FROM THE OFFICE SERVICES DIVISION OF THE OKLAHOMA DEPARTMENT OF TRANSPORTATION.

PHYSICAL ADDRESS: OKLAHOMA DEPARTMENT OF TRANSPORTATION
200 NE 21ST STREET
OKLAHOMA CITY, OKLAHOMA 73105
405-521-2586

CONSTRUCTION PLANS ARE AVAILABLE FOR DIGITAL DELIVERY THROUGH THE URL LISTED BELOW:
[HTTPS://OKLAHOMA.GOV/ODOT/ABOUT/CONTACT-US/DIVISIONS/OFFICE-SERVICES-DIVISION/PLANS-LIBRARY.HTML](https://oklahoma.gov/odot/about/contact-us/divisions/office-services-division/plans-library.html)

FOR QUESTIONS AND CONCERNS REGARDING AS-BUILT PLANS, PLEASE EMAIL: ODOT-PLANSLIBRARY@ODOT.ORG

DEBRIS REMOVAL -

REMOVE ALL DEBRIS FROM THE DECK SLAB, PIER CAPS, AND ABUTMENT SEATS. INCLUDE ALL COSTS TO REMOVE AND DISPOSE OF THE DEBRIS IN OTHER ITEMS OF WORK. ALL DRIFT AND DEBRIS DISPOSAL LOCATIONS WILL BE APPROVED BY THE ENGINEER.

CONCRETE -

PROVIDE ALL PEDESTAL CONCRETE EDGES WITH A 3/4" CHAMFER. PROVIDE ALL OTHER EXPOSED CONCRETE EDGES OF THE SUBSTRUCTURE WITH A 3/4" CHAMFER UNLESS OTHERWISE SHOWN OR NOTED. PROVIDE ALL EXPOSED CONCRETE EDGES OF THE SUPERSTRUCTURE WITH A 3/4" CHAMFER UNLESS OTHERWISE SHOWN OR NOTED. USE SIZED LUMBER FOR ALL CHAMFER STRIPS.

EQUIP CONCRETE VIBRATORS WITH A SHEATH DESIGNED TO PREVENT DAMAGE TO EPOXY COATINGS WHEN VIBRATING CONCRETE CONTAINING EPOXY COATED REINFORCING STEEL.

CONCRETE REPAIR -

CLEAN REPAIR AREA OF ALL DELAMINATED OR LOOSE CONCRETE AND DEBRIS LEAVING ONLY SOUND CONCRETE. DO NOT USE POWER TOOLS FOR REMOVING LOOSE CONCRETE UNLESS HAND TOOLS PROVE INCAPABLE OF EXCAVATING DETERIORATED CONCRETE TO SOUND CONCRETE AS DETERMINED BY THE ENGINEER. IF POWER TOOLS ARE DEEMED NECESSARY, USE TOOLS OF A SIZE THAT DO NOT DAMAGE SOUND CONCRETE. PREPARE THE GEOMETRY OF THE PATCH IN ACCORDANCE WITH FIGURE 513:1 OF THE SPECIFICATIONS. ENSURE DIMENSION OF RE-ENTRANT CORNER IS EQUAL TO AT LEAST 4 INCHES.

DO NOT CUT, STRETCH OR DAMAGE EXPOSED REINFORCING STEEL. BLAST EXPOSED REINFORCING STEEL CLEAN. REPLACE CORROSION DAMAGED REINFORCING STEEL IF MORE THAN 20% OF THE AREA OF THE SECTION HAS BEEN LOST. REPLACE OR REPAIR DAMAGED REINFORCING STEEL BY EITHER LAPPING OR PROVIDING MECHANICAL SPLICES IN ACCORDANCE WITH SECTION 511.04.C(3) OF THE SPECIFICATIONS. DO NOT LAP BARS IF EXCESSIVE REMOVAL OF SOUND CONCRETE IS REQUIRED, AS DETERMINED BY THE ENGINEER.

THE CONTRACTOR MAY USE CAST-IN-PLACE CONCRETE OR MORTAR AS THE PATCHING MATERIAL FOR THE TWO TYPES OF REPAIRS AS SHOWN IN THE DETAILS. PROVIDE CLASS AA CONCRETE IN ACCORDANCE WITH SECTION 701 OF THE SPECIFICATIONS. PROVIDE ONE OF THE FOLLOWING, COMMERCIALY AVAILABLE, MORTAR-TYPE PRODUCTS IN ACCORDANCE WITH THE MANUFACTURER'S RECOMMENDATIONS AND AS APPROVED BY THE ENGINEER.

- (1) QUIKRETE SHOTCRETE MS WITH POLYPROPYLENE FIBERS
- (2) SIKACEM 103F
- (3) SIKACEM 133
- (4) SIKACRETE 211 SCC PLUS
- (5) MASTEREMACO S 210SP
- (6) MASTEREMACO S 211SP
- (7) PROSPEC SHOTCRETE 300V

PLACE NEW PATCHING MATERIAL TO THE ORIGINAL NEAT LINES OF THE STRUCTURAL COMPONENT UNDER REPAIR AND FINISHED TO PROVIDE A SURFACE TEXTURE MATCHING THAT OF THE ADJACENT EXISTING CONCRETE. COORDINATE THE APPLICATION OF THE CORROSION INHIBITOR WITH THE CONCRETE REPAIR AS SHOWN IN THE DETAILS.

SUBMIT A PROPOSED WORK PLAN FOR THE CHOSEN REPAIR METHOD WHICH INCLUDES SURFACE PREPARATION METHODS, PATCHING MATERIAL, BONDING AGENTS, MATERIAL PLACING METHODS AND FINISHING METHODS. REPAIR A TEST AREA TO VERIFY THE EFFECTIVENESS OF THE PROPOSED REPAIR METHOD PRIOR TO COMMENCING WORK. REPLACE FAULTY REPAIRS AT NO ADDITIONAL COST TO THE DEPARTMENT.

ANCHORAGE INTO EXISTING CONCRETE -

THE CONTRACTOR WILL HAVE THE OPTION OF THE METHODS BY WHICH THE NEW ANCHOR BOLTS ARE TO BE ANCHORED INTO THE CONCRETE OF THE EXISTING BRIDGE. ANCHORAGE INTO THE CONCRETE OF THE EXISTING BRIDGE WILL BE ACCOMPLISHED BY ONE OF THE FOLLOWING METHODS:

- 1. SELF-MIXING INJECTION TYPE ANCHORAGE SYSTEM SUCH AS "HILTI FASTENING SYSTEMS", "UNITEX PRO-POXY 300 FAST" OR AN APPROVED EQUAL. ANCHORAGES WILL BE INSTALLED IN ACCORDANCE WITH THE ODOT STANDARD SPECIFICATIONS AND MANUFACTURER'S SPECIFICATIONS FOR THE SYSTEM USED.
- 2. ENCAPSULATED NON-EXPANDING CHEMICAL TYPE ANCHORAGE SYSTEMS SUCH AS "RAWLPLUG COMPANY CHEM-STUD", "HILTI ENCAPSULATED" OR AN APPROVED EQUAL. ANCHORAGES WILL BE INSTALLED IN ACCORDANCE WITH THE ODOT STANDARD SPECIFICATIONS AND MANUFACTURER'S SPECIFICATIONS FOR THE SYSTEM USED.

DRILLING INTO THE EXISTING CONCRETE TO INSTALL THE ANCHORAGE WILL BE ACCOMPLISHED WITHOUT CUTTING THE EXISTING CONCRETE REINFORCING STEEL. PRIOR TO DRILLING, THE CONTRACTOR WILL LOCATE AND MARK THE EXISTING CONCRETE REINFORCING STEEL WITH NONDESTRUCTIVE TOOLS, EQUIPMENT AND METHODS APPROVED BY THE ENGINEER. IF EXISTING REINFORCING STEEL IS ENCOUNTERED DURING DRILLING, THE DRILLING WILL CEASE AND THEN THE HOLE WILL BE GROUTED. THE HOLE WILL THEN BE RELOCATED TO CLEAR THE EXISTING REINFORCING STEEL. ANY ADJUSTMENT IN THE LOCATIONS OF THE NEW ANCHOR BOLTS FROM THE PLAN LOCATIONS SHOWN WILL BE THE MINIMUM AMOUNT NECESSARY TO AVOID CUTTING THE EXISTING CONCRETE REINFORCING STEEL AND WILL BE APPROVED BY THE ENGINEER.

ALL COST TO ANCHOR THE NEW ANCHOR BOLTS INTO THE EXISTING BRIDGE AS SPECIFIED OR AS SHOWN IN THE PLANS INCLUDING THE COST OF LOCATING EXISTING CONCRETE REINFORCING STEEL, DRILLING, REPAIRING FLAWED DRILL HOLES, ANCHORING INTO THE EXISTING CONCRETE, MATERIALS, LABOR, EQUIPMENT AND INCIDENTALS WILL BE INCLUDED IN OTHER ITEMS OF WORK.

WATER REPELLENT TREATMENT -

APPLY WATER REPELLENT TREATMENT TO THE BRIDGE IN A MANNER CONSISTENT WITH THE DETAILS SHOWN IN THE PLANS.

STRUCTURAL STEEL -

PROVIDE STRUCTURAL STEEL FOR ANCHOR PLATES AND ANCHOR BOLTS IN ACCORDANCE WITH AASHTO M270 (ASTM A709), GRADE 50W (WEATHERING STEEL, CHARPY V-NOTCH TESTING NOT REQUIRED). PROVIDE ALL BOLTS, NUTS, WASHERS AND WELDING WITH WEATHERING CHARACTERISTICS. PROVIDE STRUCTURAL STEEL FOR PIPE IN ACCORDANCE WITH ASTM A53 GRADE B.

SURVEYING AND CONSTRUCTION STAKING -

THE CONTRACTOR WILL BE REQUIRED TO CONDUCT ALL SURVEYING AND CONSTRUCTION STAKING NECESSARY FOR THE COMPLETION OF THE PROJECT AS DIRECTED BY THE ENGINEER. THE SURVEYING AND CONSTRUCTION STAKING REQUIRED FOR COMPLETION OF THE PROJECT MAY INCLUDE THE FOLLOWING:

- 1. ESTABLISHING HORIZONTAL CONTROL INCLUDING THE STAKING OF CENTERLINE BRIDGE AND APPROACH ROADWAY.
- 2. ESTABLISHING VERTICAL CONTROL INCLUDING THE SETTING OF BENCHMARKS.
- 3. MEASURING THE ELEVATIONS ALONG THE EXISTING BRIDGE DECK AT CENTERLINE AND EDGES OF DECK SLAB.
- 4. MEASURING THE ELEVATIONS ALONG THE EXISTING APPROACH ROADWAY AT CENTER LINE AND EDGES.
- 5. MEASURING AND SETTING CONSTRUCTION STAKES AS NECESSARY FOR CONDUCTING THE GRADING AND SURFACING WORK ON THE APPROACH ROADWAY.

ALL SURVEY DATA WILL BE PROVIDED TO THE ENGINEER FOR APPROVAL BEFORE CONSTRUCTING THE CONCRETE DECK OVERLAY AND APPROACH ROADWAY PAVEMENT.

ALL COST OF THE SURVEYING AND CONSTRUCTION STAKING NECESSARY FOR COMPLETION OF THE PROJECT AS DIRECTED BY THE ENGINEER INCLUDING THE COST OF MATERIALS, LABOR, EQUIPMENT, AND INCIDENTALS WILL BE INCLUDED IN THE UNIT PRICE BID PER LUMP SUM OF "CONSTRUCTION STAKING LEVEL II".

PAINTING EXISTING STRUCTURES -

CLEAN AND PAINT THE BRIDGE COMPONENTS LISTED BELOW AND AS SHOWN IN THE PLANS IN ACCORDANCE WITH THE MANUFACTURER'S RECOMMENDATIONS AND SECTION 512 OF THE SPECIFICATIONS USING A CATEGORY "E" APPLICATION. MATCH THE COLOR OF THE TOP COAT FOR THE EXTERIOR SURFACES.

THIS ITEM CONSISTS OF THE FOLLOWING COMPONENTS:

- (A) BEAMS AND COVER PLATES ESTIMATED AT 5,900 SQUARE FEET.
- (B) DIAPHRAGMS AND CONNECTION PLATES ESTIMATED AT 900 SQUARE FEET.
- (C) BEARING STIFFENERS ESTIMATED AT 45 SQUARE FEET.
- (D) BEARING ASSEMBLIES INCLUDING ANCHOR PLATES ESTIMATED AT 90 SQUARE FEET.
- (E) HANDRAILS ESTIMATED AT 710 SQUARE FEET.

EXERCISE CARE TO ENSURE THAT NO DAMAGE IS CAUSED TO TRAFFIC DURING CLEANING AND PAINTING OPERATIONS. USE TARPS AND OTHER NECESSARY EQUIPMENT AS APPROVED BY THE ENGINEER. THE CONTRACTOR WILL BE SOLELY RESPONSIBLE FOR SECURING THE PAINT APPLICATION.

REMOVED MATERIAL -

ALL MATERIAL AND DEBRIS REMOVED DURING THIS PROJECT WILL BECOME THE PROPERTY OF THE CONTRACTOR AND WILL BE DISPOSED OF IN A MANNER APPROVED BY THE ENGINEER.

EXISTING STEEL STRUCTURES -

REPORT ANY DETERIORATED STRUCTURAL STEEL EXPOSED DURING OPERATIONS TO THE ENGINEER FOR REMEDIAL ACTION. PROVIDE REPLACEMENT STRUCTURAL STEEL IN ACCORDANCE WITH AASHTO M270 (ASTM A709), GRADE 36 OR HIGHER. MAKE ALL WELDS TO SOUND STEEL. ADJUST WELD LOCATIONS AND EXTENTS OF NEW STRUCTURAL STEEL IF SOUND STEEL IS NOT FOUND AT LOCATIONS SHOWN IN THE PLANS. PERFORM ALL WELDING OPERATIONS IN ACCORDANCE WITH SECTION 724.03 OF THE SPECIFICATIONS AND THE CURRENT ANSI/AASHTO/AWS D1.5 BRIDGE WELDING CODE. ALL FIELD WELDS WILL BE INSPECTED BY THE CITY OF LAWTON OR THEIR REPRESENTATIVE. CONTACT THE CITY OF LAWTON AT LEAST 72 HOURS PRIOR TO THE ANTICIPATED COMPLETION OF FIELD WELDS.

ELASTOMERIC COATING -

THE ELASTOMERIC COATING WILL BE A LIQUID APPLIED URETHANE COATING SUCH AS CIM 1000 AS MANUFACTURED BY CIM INDUSTRIES, INC., IM-129 AS MANUFACTURED BY CUSTOM LININGS. PRODUCT INFORMATION FOR CIM 1000 CAN BE OBTAINED FROM LASTER CASTOR CORP. OF TULSA, OKLAHOMA, PHONE NUMBER 918-234-7777. PRODUCT INFORMATION FOR IM-129 CAN BE OBTAINED FROM CUSTOM LININGS, PHONE NUMBER 719-374-8785. THE EQUIPMENT AND METHODS OF APPLYING THE URETHANE COATING WILL BE IN ACCORDANCE WITH THE PRODUCT COATING PROFILE AND INSTRUCTION GUIDES FOR APPLICATION TO CONCRETE. PRECAUTIONARY MEASURES WILL BE IN ACCORDANCE WITH THE MATERIAL SAFETY DATA SHEETS AS PROVIDED BY THE MANUFACTURER. THE COATING WILL BE 60 MILS DRY THICKNESS AND 68 MILS WET THICKNESS. IN ADDITION TO APPLYING THE COATING TO THE CONCRETE SUBSTRUCTURE UNITS AS LISTED BELOW, THE COATING WILL RETURN UP THE VERTICAL FACES OF THE PIER AND ABUTMENT BEARING ASSEMBLY BASE PLATES TO PROVIDE A WATER TIGHT SEAL WITH THE CONCRETE PEDESTALS. SURFACE PREPARATIONS AND PRODUCT MIXING WILL BE PER THE MANUFACTURER'S RECOMMENDATIONS AND ALL NEW CONCRETE WILL HAVE A MINIMUM STRENGTH OF 3000 PSI AT THE TIME OF APPLICATION. PRIMER WILL BE APPLIED TO THE CONCRETE SURFACES PRIOR TO APPLYING THE COATING. ALL CONCRETE WORK WILL BE COMPLETED PRIOR TO THE APPLICATION OF THE SPECIAL CONCRETE FINISH.

WATER REPELLENT WILL NOT BE REQUIRED ON SURFACES THAT ARE COATED WITH ELASTOMERIC COATING. ELASTOMERIC COATING WILL BE APPLIED TO ALL AREAS LISTED AND DETAILED BELOW:

- 1. ABUTMENT CAPS AND BACKWALLS
- 2. PIER CAPS

ALL COSTS OF THE ELASTOMERIC COATING INCLUDING THE COST OF MATERIALS, LABOR, EQUIPMENT, AND INCIDENTALS WILL BE INCLUDED IN THE PRICE BID PER SQUARE FOOT OF "ELASTOMERIC COATING".

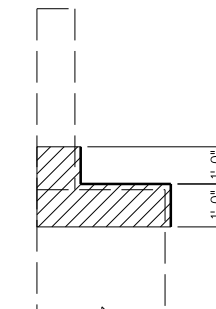

ABUTMENTS

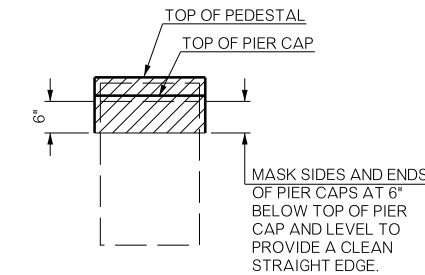

PIERS

NOTE: APPLY ELASTOMERIC COATING TO ALL SURFACES SHOWN WITH HEAVY LINES AND HATCH (INCLUDING PEDESTAL STEPS AND ENDS OF CAPS).

Design		CACHE ROAD OVER WOLF CREEK	COMANCHE COUNTY
Drawn		BRIDGES 'A' AND 'B'	
Checked			
Approved			
Squad			

GENERAL NOTES - BRIDGE

City Project EN2112 Sheet No. 3

PROJECT DIST NO.	STATE	JEP PROJ NO.	FISCAL YEAR	SHEET NO.	TOTAL SHEETS
*	OKLA	*****	**		----

PAY ITEM NOTES

- QUANTITY INCLUDES 50 C.Y. TO BE USED AS DIRECTED BY THE ENGINEER.
- ITEM "CLSM BACKFILL" INCLUDES 10.0 CY TO BE USED AS DIRECTED BY THE ENGINEER FOR FILLING VOIDS UNDER THE ABUTMENT SEATS AND APPROACH SLABS AS NEEDED TO ENSURE CONTINUOUS SUPPORT.
- ITEM "(PL) FALSEWORK JACKING" CONSISTS OF SUPPORTING THE BRIDGE THROUGHOUT CONSTRUCTION ACTIVITIES ASSOCIATED WITH SUPERSTRUCTURE AND SUBSTRUCTURE REPAIRS AS NECESSARY IN ACCORDANCE WITH SECTION 502 OF THE SPECIFICATIONS. SUBMIT A WORK PLAN SEALED BY A PROFESSIONAL ENGINEER LICENSED IN THE STATE OF OKLAHOMA TO THE ENGINEER FOR APPROVAL. DO NOT BEGIN JACKING OPERATIONS UNTIL APPROVAL OF THE PLAN BY THE ENGINEER IS RECEIVED. INCLUDE ALL COSTS ASSOCIATED WITH JACKING OPERATIONS, INCLUDING PROFESSIONAL SERVICES, IN THE CONTRACT UNIT PRICE OF "(PL) FALSEWORK JACKING".
- PAYMENT TO THE CONTRACTOR WILL BE BASED ON PLAN QUANTITIES.
- QUANTITY INCLUDES 500 LB. TO BE USED FOR REPLACING DETERIORATED STRUCTURAL STEEL AS DETERMINED BY THE ENGINEER. QUANTITY SHOWN INCLUDES STRUCTURAL STEEL TO BE USED AS BACKWALL PLATES FOR SUPPORTING THE EXPANSION JOINTS ALONG THE ABUTMENT BACKWALL.
- THE EXPANSION BEARING ASSEMBLIES CONTAIN AN ESTIMATED STRUCTURAL STEEL TOTAL OF 920.00 LB. AT BRIDGE 'A' AND 610 LB. AT BRIDGE 'B'.
- THE PAY ITEMS "CLASS AA CONCRETE", "EPOXY COATED REINFORCING STEEL", "SEALED EXPANSION JOINTS" INCLUDE QUANTITIES FOR REPLACING THE EXISTING BRIDGE BRIDGE DECK JOINTS AS SHOWN ON THE PLANS AND AS DIRECTED BY THE ENGINEER. REPLACE WITH CLASS AA CONCRETE, EPOXY COATING REINFORCING STEEL AND SEALED EXPANSION JOINT IN ACCORDANCE WITH SECTIONS 504, 509, AND 511 OF THE STANDARD SPECIFICATIONS AND AS SHOWN ON THE PLANS.

QUANTITIES FOR CONCRETE, REINFORCING STEEL AND STRUCTURAL STEEL NEEDED TO RECONSTRUCT THE BRIDGE DECKS FOR THE BRIDGE DECK JOINT REPLACEMENT WILL BE INCLUDED IN THEIR RESPECTIVE BID ITEMS FOR "CLASS AA CONCRETE", "EPOXY COATED REINFORCING STEEL" AND "STRUCTURAL STEEL". ALL COSTS FOR THE SEALED EXPANSION JOINT, DRILLING AND BONDING AGENTS WILL BE INCLUDED IN THE UNIT PRICE BID PER LINEAR FOOT OF "SEALED EXPANSION JOINTS".
- ITEM "CLASS C CONCRETE" CONSISTS OF 15.0 C.Y. TO BE USED AT THE DIRECTION OF THE ENGINEER.
- ITEM "REINFORCING STEEL" CONSISTS OF 1,000 LB. PROVIDING REPLACEMENT REINFORCING STEEL IN THE ABUTMENTS AND PIERS HAVING A SECTION LOSS OF 50% OR MORE DETERMINED IN THE FIELD BY THE ENGINEER.
- CLEAN AND PAINT THE BRIDGE COMPONENTS LISTED BELOW AND AS SHOWN IN THE PLANS IN ACCORDANCE WITH THE MANUFACTURER'S RECOMMENDATIONS AND SECTION 512 OF THE SPECIFICATIONS USING A CATEGORY "E" APPLICATION. THE TOPCOAT FOR THE EXTERIOR SURFACES FOR METAL HANDRAIL SHALL BE PER FEDERAL COLOR NUMBERS 10032, 10059, OR 17038. METAL BELOW THE BRIDGE DECKS SHALL BE PER FEDERAL COLOR NUMBERS 30045, 30097, OR 30108. PRIOR TO APPLICATION CONTRACTOR SHALL SUBMIT A 2'X2' STEEL SAMPLE OF EACH COLOR TO THE CITY OF LAWTON FOR REVIEW AND FINAL COLOR SELECTION.

THIS ITEM CONSISTS OF THE FOLLOWING COMPONENTS:
(A) BEAMS AND COVER PLATES ESTIMATED AT 5,900 SQUARE FEET.
(B) DIAPHRAGMS AND CONNECTION PLATES ESTIMATED AT 900 SQUARE FEET.
(C) BEARING STIFFENERS ESTIMATED AT 45 SQUARE FEET.
(D) BEARING ASSEMBLIES INCLUDING ANCHOR PLATES ESTIMATED AT 90 SQUARE FEET.
(E) HANDRAILS ESTIMATED AT 710 SQUARE FEET.
- SSPC QP-2 CERTIFICATION WILL BE REQUIRED. REPORT THE FINDING OF ANY LEAD PAINT TO THE ENGINEER. PERSONNEL WITH SSPC C-3 SUPERVISOR/COMPETENT PERSON TRAINING FOR DELEADING OF INDUSTRIAL STRUCTURES MAY BE USED IN LIEU OF SSPC QP-2 CERTIFICATION. IF PERSONNEL WITH SSPC C-3 TRAINING ARE TO BE USED, PROVIDE A CURRENT CERTIFICATE SHOWING SUCCESSFUL COMPLETION OF THE SSPC C-3 TRAINING WITH THE BID PROPOSAL. THE SUPERVISOR WITH SSPC C-3 TRAINING WILL BE REQUIRED TO BE PRESENT AT THE PROJECT SITE THE ENTIRE TIME THAT DELEADING OPERATIONS ARE TAKING PLACE AT THE PROJECT SITE. THE CONTRACTOR WILL BE RESPONSIBLE FOR TESTING AND COMPLYING WITH SECTION 512 OF THE SPECIFICATIONS FOR HAZARDOUS AND NON-HAZARDOUS WASTE.
- QUANTITY INCLUDES 15 S.Y. TO BE USED AS DIRECTED BY THE ENGINEER.
- REPAIR AREAS SHOWN IN THE PLANS AND AS DIRECTED BY THE ENGINEER. QUANTITY SHOWN IS APPROXIMATE AND SUBJECT TO THE ACTUAL LOCATIONS AND EXTENTS OF REPAIRS DETERMINED IN THE FIELD BY THE ENGINEER. ALL REMOVED MATERIALS WILL BECOME THE PROPERTY OF THE CONTRACTOR. SEE PLANS FOR ESTIMATED QUANTITIES AND LOCATIONS.
- QUANTITY SHOWN FOR EPOXY RESIN ESTIMATED AT 0.08 GALLONS PER FOOT OF CRACK REPAIR.
- ITEM "CORROSION INHIBITOR (SURFACE APPLIED)" CONSISTS OF APPLYING A CORROSION INHIBITOR AT THE LOCATIONS SHOWN ON THE PLANS OR AS DIRECTED BY THE ENGINEER.

QUANTITY SHOWN INCLUDES 40 S.Y. TO BE USED AS DIRECTED BY THE ENGINEER.
- ITEM "(PL) REPAIR BRIDGE ITEMS" CONSISTS OF REPAIRING DETERIORATED CONCRETE WITH PNEUMATICALLY PLACED MORTAR OR CLASS AA CONCRETE MATERIAL AS DESCRIBED IN THE GENERAL NOTES, AS SHOWN IN THE PLANS AND IN A MANNER APPROVED BY THE ENGINEER.
- QUANTITY INCLUDES 25 S.Y. TO BE USED AS DIRECTED BY THE ENGINEER.
- QUANTITY SHOWN FOR TYPE I PLAIN RIPRAP ESTIMATED AT 110 LB PER CUBIC FOOT.

- ITEM "REMOVAL OF BRIDGE ITEMS" CONSISTS OF REMOVAL AND DISPOSAL OF PORTIONS OF THE BRIDGE DECKS, PARAPETS, APPROACH SLABS, EXPANSION JOINTS (INCLUDING SAWING) AND BEARINGS IN ACCORDANCE WITH SUBSECTION 619.04(B)2 OF THE SPECIFICATIONS AND IN A MANNER APPROVED BY THE ENGINEER. ALL REMOVED MATERIALS WILL BECOME THE PROPERTY OF THE CONTRACTOR.

THE HANDRAILS ON TOP OF THE EXISTING PARAPETS WILL REMAIN IN PLACE. THE CONTRACTOR WILL TAKE CARE NOT TO DAMAGE THE HANDRAIL AND COMPONENTS AND REATTACH THE HANDRAILS TO THE NEW PARAPETS.

INCLUDE ALL COSTS FOR LABOR, EQUIPMENT AND INCIDENTALS NECESSARY TO COMPLETE THE WORK IN THE LUMP SUM PRICE BID OF "REMOVAL OF BRIDGE ITEMS".

PAY QUANTITIES				
0200 BRIDGE 'A' - WESTBOUND				
ITEM NO.		DESCRIPTION	UNIT	TOTAL
202(D)	2510	UNCLASSIFIED BORROW	(1) CY	50.00
501(G)	1800	CLSM BACKFILL	(2) CY	18.10
502(B)	3320	(PL)FALSEWORK JACKING	(3) LSUM	1.00
504(B)	5300	SAW-CUT GROOVING	(4) SY	202.70
504(E)	5500	CONCRETE PARAPET	(4) LF	84.00
506(A)	7200	STRUCTURAL STEEL	(5) LB	550.00
507(B)	8310	WEATHERING STL EXP. BEARING ASSEMBLY	(4, 6) EA	6.00
509(A)	0210	CLASS AA CONCRETE	(4, 7) CY	59.60
509(D)	0510	CLASS C CONCRETE	(8) CY	15.00
511	2100	MECHANICAL SPLICES	EA	220.00
511(A)	2210	REINFORCING STEEL	(9) LB	1,000.00
511(B)	2310	EPOXY COATED REINFORCING STEEL	(4, 7) LB	16,480.00
512(A)	3200	PAINTING EXISTING STRUCTURES	(10) LSUM	1.00
512(B)	3300	COLLECTION AND HANDLING OF WASTE	(11) LSUM	1.00
513(B)	4300	CLASS B BRIDGE DECK REPAIR	(12) SY	37.90
513(C)	4400	CLASS C BRIDGE DECK REPAIR	(12) SY	15.00
515(A)	7200	WATER REPELLENT (VISUALLY INSPECTED)	(4) SY	322.00
517	9110	ELASTOMERIC COATING	(4) SF	870.00
518(B)	0300	SEALED EXPANSION JOINTS	(4, 7) LF	84.00
518(C)	0400	RAPID CURE JOINT SEALANT	LF	83.50
520(A)	1200	PREPARATION OF CRACKS, ABOVE WATER	(13) LF	3.00
520(C)	1400	EPOXY RESIN, ABOVE WATER	(13, 14) GAL	0.30
523(C)	3400	DECK AREA SEALED (FLOODCOATS)	(4) SY	809.00
535	7100	CORROSION INHIBITOR (SURFACE APPLIED)	(13, 15) SY	68.60
540	8112	(PL) REPAIR BRIDGE ITEMS	(13, 16, 17) SY	44.00
601(A)	1110	TYPE I PLAIN RIPRAP	(18) TON	740.00
619(B)	6304	REMOVAL OF BRIDGE ITEMS	(19) LSUM	1.00

PAY QUANTITIES				
0201 BRIDGE 'B' - EASTBOUND				
ITEM NO.		DESCRIPTION	UNIT	TOTAL
202(D)	2510	UNCLASSIFIED BORROW	(1) CY	50.00
501(G)	1800	CLSM BACKFILL	(2) CY	22.50
502(B)	3320	(PL)FALSEWORK JACKING	(3) LSUM	1.00
504	5140	HANGERS	(4) EA	10.00
504(B)	5300	SAW-CUT GROOVING	(4) SY	202.70
504(E)	5500	CONCRETE PARAPET	(4) LF	84.00
506(A)	7200	STRUCTURAL STEEL	(5) LB	550.00
507(B)	8310	WEATHERING STL EXP. BEARING ASSEMBLY	(4, 6) EA	4.00
509(A)	0210	CLASS AA CONCRETE	(4, 7) CY	59.60
509(D)	0510	CLASS C CONCRETE	(8) CY	15.00
511	2100	MECHANICAL SPLICES	EA	220.00
511(A)	2210	REINFORCING STEEL	(9) LB	1,000.00
511(B)	2310	EPOXY COATED REINFORCING STEEL	(4, 7) LB	16,480.00
512(A)	3200	PAINTING EXISTING STRUCTURES	(10) LSUM	1.00
512(B)	3300	COLLECTION AND HANDLING OF WASTE	(11) LSUM	1.00
513(B)	4300	CLASS B BRIDGE DECK REPAIR	(12) SY	78.10
513(C)	4400	CLASS C BRIDGE DECK REPAIR	(12) SY	15.00
515(A)	7200	WATER REPELLENT (VISUALLY INSPECTED)	(4) SY	322.00
517	9110	ELASTOMERIC COATING	(4) SF	870.00
518(B)	0300	SEALED EXPANSION JOINTS	(4, 7) LF	84.00
518(C)	0400	RAPID CURE JOINT SEALANT	LF	83.50
520(A)	1200	PREPARATION OF CRACKS, ABOVE WATER	(13) LF	10.00
520(C)	1400	EPOXY RESIN, ABOVE WATER	(13, 14) GAL	0.90
523(C)	3400	DECK AREA SEALED (FLOODCOATS)	(4) SY	809.00
535	7100	CORROSION INHIBITOR (SURFACE APPLIED)	(13, 15) SY	55.50
540	8112	(PL) REPAIR BRIDGE ITEMS	(13, 16, 17) SY	35.30
601(A)	1110	TYPE I PLAIN RIPRAP	(18) TON	740.00
619(B)	6304	REMOVAL OF BRIDGE ITEMS	(19) LSUM	1.00

PAY QUANTITY NOTES

PAY ITEMS ARE BASED ON ODOT 2019 SPECIFICATIONS

CONSTRUCTION PAY QUANTITIES				
0640 CONSTRUCTION				
ITEM NO.		DESCRIPTION	UNIT	TOTAL
641	2100	MOBILIZATION	LSUM	1.00
642(B)	3300	CONSTRUCTION STAKING LEVEL II	LSUM	1.00

THE CONTRACTOR SHALL COORDINATE ALL WORK WITH CITY OF LAWTON PROJECT PU2202. COORDINATION SHALL INCLUDE THE CITY OF LAWTON, ENGINEER AND CONTRACTOR FOR PROJECT PU2202 AND EN2112.

Design		CACHE ROAD OVER WOLF CREEK BRIDGES 'A' AND 'B' SUMMARY OF BRIDGE PAY QUANTITIES City Project <u>EN2112</u> Sheet No. <u>4</u>
Drawn		
Checked		
Approved		
Squad		

PROJECT DIST NO.	STATE	J.P. PROJ. NO.	FISCAL YEAR	SHEET NO.	TOTAL SHEETS
..	OKLA	*****	**	..	----



BRIDGE A

NEW CONSTRUCTION DESIGN DATA

MATERIAL
 CLASS AA CONCRETE f'c = 4 KSI
 CLASS A CONCRETE f'c = 3 KSI
 REINFORCING STEEL (GRADE 60) fy = 60 KSI
 STRUCTURAL STEEL M270 (GRADE 50W) fy = 50 KSI

INDEX OF SHEETS

- 3 GENERAL NOTES - BRIDGE
- 4 SUMMARY OF BRIDGE PAY QUANTITIES
- 5 GENERAL PLAN AND ELEVATION - BRIDGE 'A'
- 6 GENERAL PLAN AND ELEVATION - BRIDGE 'B'
- 7 BRIDGE CONSTRUCTION SEQUENCE
- 8-10 ABUTMENT DETAILS
- 11-13 PIER DETAILS
- 14-21 SUPERSTRUCTURE DETAILS
- 22 RIPRAP PLAN

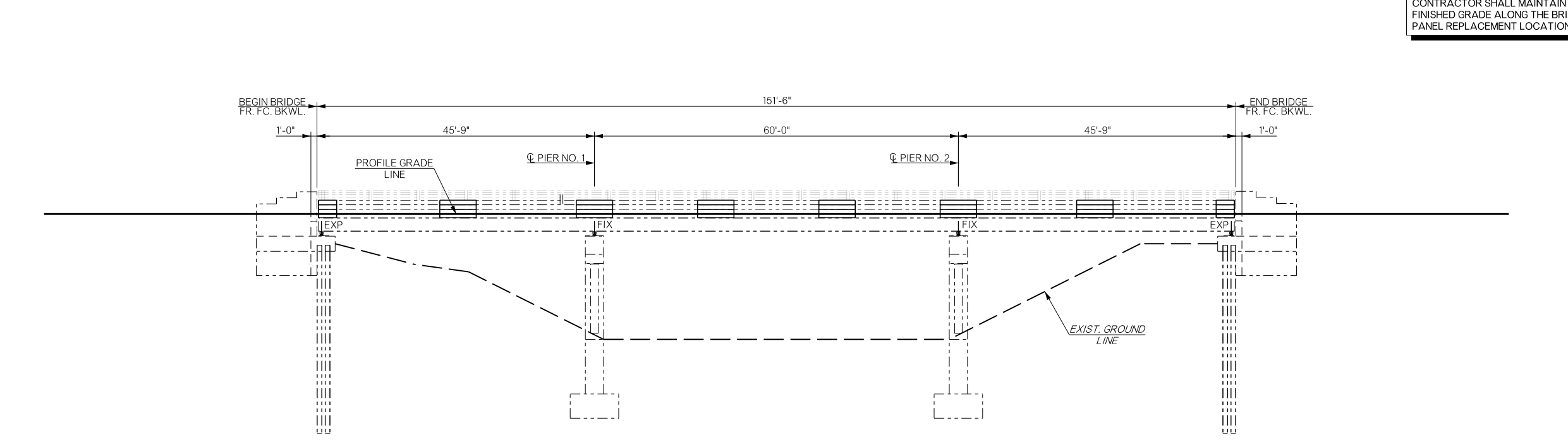
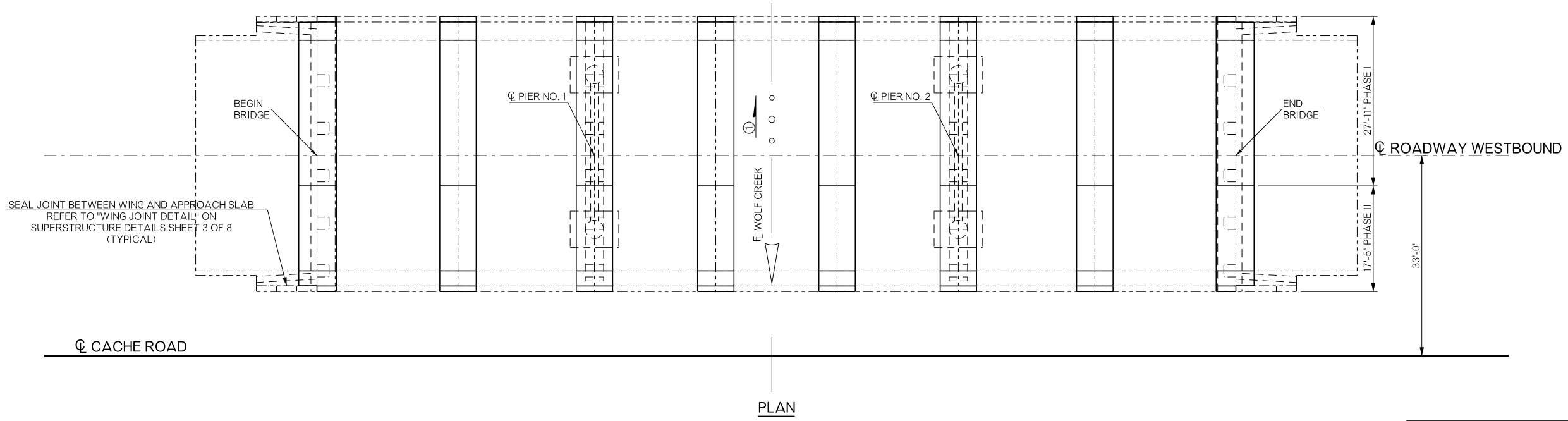

CONTRACTOR SHALL MAINTAIN THE EXISTING FINISHED GRADE ALONG THE BRIDGE DECK AT ALL PANEL REPLACEMENT LOCATIONS

THE CONTRACTOR SHALL COORDINATE ALL WORK WITH CITY OF LAWTON PROJECT PU2202. COORDINATION SHALL INCLUDE THE CITY OF LAWTON, ENGINEER AND CONTRACTOR FOR PROJECT PU2202 AND EN2112.

ALIGNMENT, AND EXISTING GRADE DATA ARE TAKEN FROM RECORD DRAWINGS AND ARE FOR INFORMATIONAL PURPOSES ONLY.

① THE EXISTING DECK CROSS SLOPE IS 3/8" PER FOOT. DECK CROSS SLOPE SHOWN IS AS DETAILED IN THE EXISTING PLANS OF THE EXISTING BRIDGE. MATCH THE ACTUAL EXISTING CROSS SLOPE MEASURED IN THE FIELD.

Design	
Drawn	
Checked	
Approved	
Squad	

CACHE ROAD OVER WOLF CREEK COMANCHE COUNTY
 BRIDGE 'A' - WESTBOUND

GENERAL PLAN AND ELEVATION

PROJECT DIST NO.	STATE	J.P. PROJ. NO.	FISCAL YEAR	SHEET NO.	TOTAL SHEETS
.	OKLA	*****	**	---	---

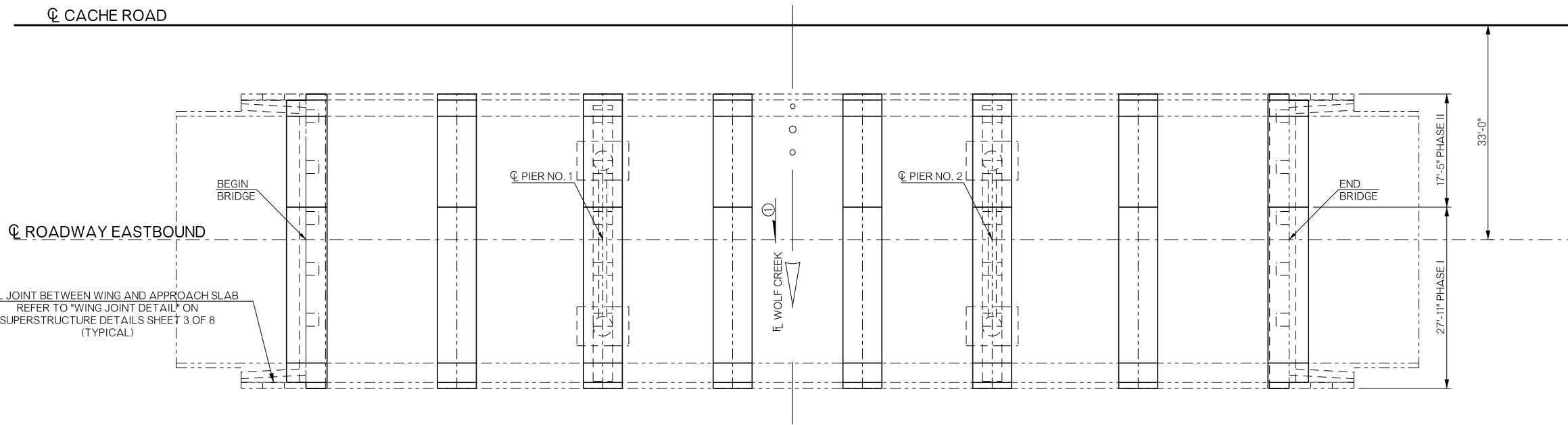

BRIDGE B

NEW CONSTRUCTION DESIGN DATA

MATERIAL
 CLASS AA CONCRETE f'c = 4 KSI
 CLASS A CONCRETE f'c = 3 KSI
 REINFORCING STEEL (GRADE 60) fy = 60 KSI
 STRUCTURAL STEEL M270 (GRADE 50W) fy = 50 KSI

INDEX OF SHEETS

- 3 GENERAL NOTES - BRIDGE
- 4 SUMMARY OF BRIDGE PAY QUANTITIES
- 5 GENERAL PLAN AND ELEVATION - BRIDGE 'A'
- 6 GENERAL PLAN AND ELEVATION - BRIDGE 'B'
- 7 BRIDGE CONSTRUCTION SEQUENCE
- 8-10 ABUTMENT DETAILS
- 11-13 PIER DETAILS
- 14-21 SUPERSTRUCTURE DETAILS
- 22 RIPRAP PLAN

PLAN

CONTRACTOR SHALL MAINTAIN THE EXISTING FINISHED GRADE ALONG THE BRIDGE DECK AT ALL PANEL REPLACEMENT LOCATIONS

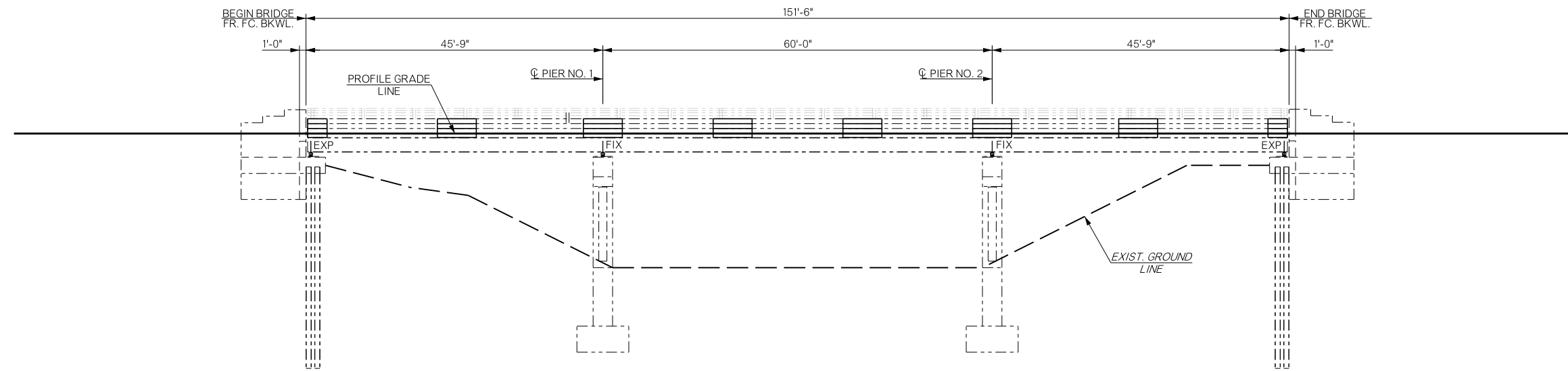

ELEVATION

THE CONTRACTOR SHALL COORDINATE ALL WORK WITH CITY OF LAWTON PROJECT PU2202. COORDINATION SHALL INCLUDE THE CITY OF LAWTON, ENGINEER AND CONTRACTOR FOR PROJECT PU2202 AND EN2112.

ALIGNMENT, AND EXISTING GRADE DATA ARE TAKEN FROM RECORD DRAWINGS AND ARE FOR INFORMATIONAL PURPOSES ONLY.

① THE EXISTING DECK CROSS SLOPE IS 3/16" PER FOOT. DECK CROSS SLOPE SHOWN IS AS DETAILED IN THE EXISTING PLANS OF THE EXISTING BRIDGE. MATCH THE ACTUAL EXISTING CROSS SLOPE MEASURED IN THE FIELD.

Design	
Drawn	
Checked	
Approved	
Squad	

CACHE ROAD OVER WOLF CREEK BRIDGE 'B' - EASTBOUND COMANCHE COUNTY

GENERAL PLAN AND ELEVATION

FED ROAD DISTNO	STATE	APPROJNO	FISCAL YEAR	SHEET NO	TOTAL SHEETS
*	OKLA	*****	**		

SUMMARY OF QUANTITIES												
ITEM	UNIT	BRIDGE 'A' - WESTBOUND					BRIDGE 'B' - EASTBOUND					TOTAL
		ABUTMENT	PIER	SUPERSTRUCTURE	ADDITIONAL	SUBTOTAL	ABUTMENT	PIER	SUPERSTRUCTURE	ADDITIONAL	SUBTOTAL	
UNCLASSIFIED BORROW	CY				50.00	50.00				50.00	50.00	100.00
CLSM BACKFILL	CY	8.10			10.00	18.10	12.50			10.00	22.50	40.60
(PL)FALSEWORK JACKING	LSUM				1.00	1.00				1.00	1.00	2.00
SAW-CUT GROOVING	SY			50.70	152.00	202.70			50.70	152.00	202.70	405.40
CONCRETE PARAPET	LF			84.00		84.00			84.00		84.00	168.00
STRUCTURAL STEEL	LB			50.00	500.00	550.00			50.00	500.00	550.00	1,100.00
WEATHERING STEEL EXPANSION BEARING ASSEMBLY	EA			6.00		6.00			4.00		4.00	10.00
CLASS AA CONCRETE	CY			59.60		59.60			59.60		59.60	119.20
CLASS C CONCRETE	CY				15.00	15.00			15.00		15.00	30.00
MECHANICAL SPLICES	EA			220.00		220.00			220.00		220.00	440.00
REINFORCING STEEL	LB				1,000.00	1,000.00				1,000.00	1,000.00	2,000.00
EPOXY COATED REINFORCING STEEL	LB			16,480.00		16,480.00			16,480.00		16,480.00	32,960.00
PAINTING EXISTING STRUCTURES	LSUM			1.00		1.00			1.00		1.00	2.00
COLLECTION AND HANDLING OF WASTE	LSUM			1.00		1.00			1.00		1.00	2.00
CLASS B BRIDGE REPAIR	SY			22.90	15.00	37.90			63.10	15.00	78.10	116.10
CLASS C BRIDGE REPAIR	SY				15.00	15.00				15.00	15.00	30.00
WATER REPELLENT (VISUALLY INSPECTED)	SY	38.00	84.00	200.00		322.00	38.00	84.00	200.00		322.00	644.00
ELASTOMERIC COATING	SF	488.00	382.00			870.00	488.00	382.00			870.00	1,740.00
SEALED EXPANSION JOINTS	LF			84.00		84.00			84.00		84.00	168.00
RAPID CURE JOINT SEALANT	LF			83.50		83.50			83.50		83.50	167.00
PREPERATION OF CRACKS ABOVE WATER	LF	3.00				3.00	4.00	6.00			10.00	13.00
EPOXY RESIN ABOVE WATER	GAL	0.30				0.30	0.40	0.50			0.90	1.20
DECK AREA SEALED (FLOODCOATS)	SY			809.00		809.00			809.00		809.00	1,618.00
CORROSION INHIBITOR (SURFACE APPLIED)	SY	6.00	22.60		40.00	68.60	5.30	10.20		40.00	55.50	124.10
(PL) REPAIR BRIDGE ITEMS	SY	4.00	15.00		25.00	44.00	3.50	6.80		25.00	35.30	79.30
TYPE I PLAIN RIPRAP	TON				740.00	740.00				740.00	740.00	1,480.00
REMOVAL OF BRIDGE ITEMS	LSUM				1.00	1.00				1.00	1.00	2.00
HANGERS	EA									10.00	10.00	10.00

Design		CACHE ROAD OVER WOLF CREEK	COMANCHE COUNTY
Drawn		SUMMARY SHEET BRIDGE PAY ITEMS City Project <u>EN2112</u> Sheet No. <u>7</u>	
Checked			
Approved			
Squad			

PROJECT DIST NO.	STATE	J.P. PROJECT NO.	FISCAL YEAR	SHEET NO.	TOTAL SHEETS
..	OKLA	*****	**	---	---

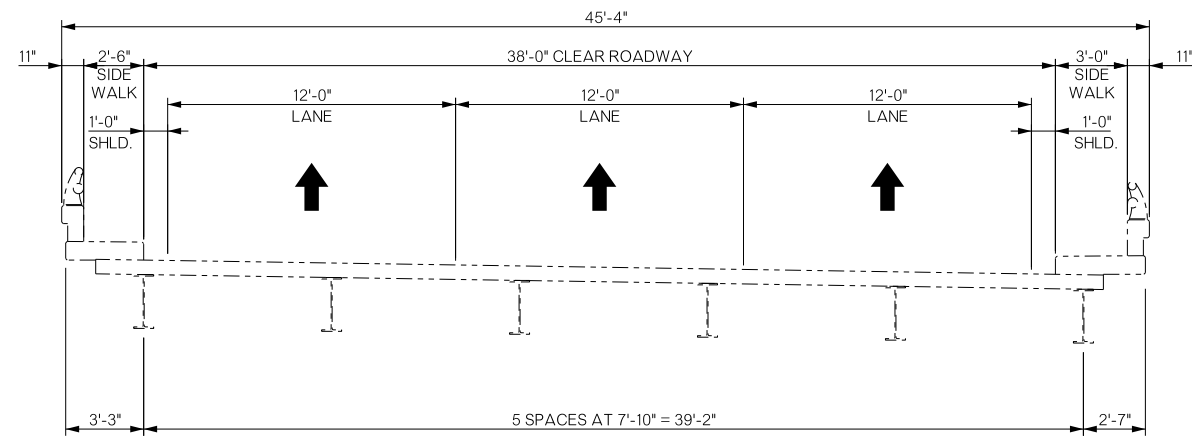

EXISTING BRIDGE

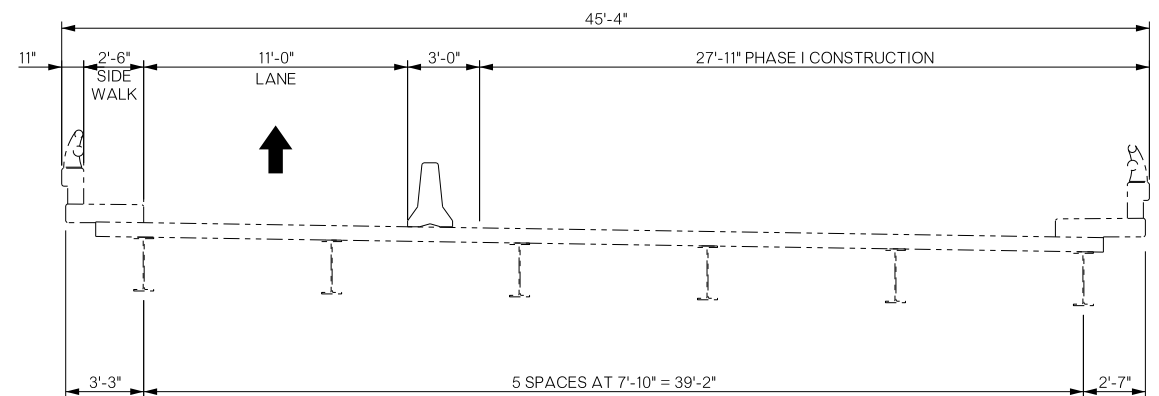

PHASE I

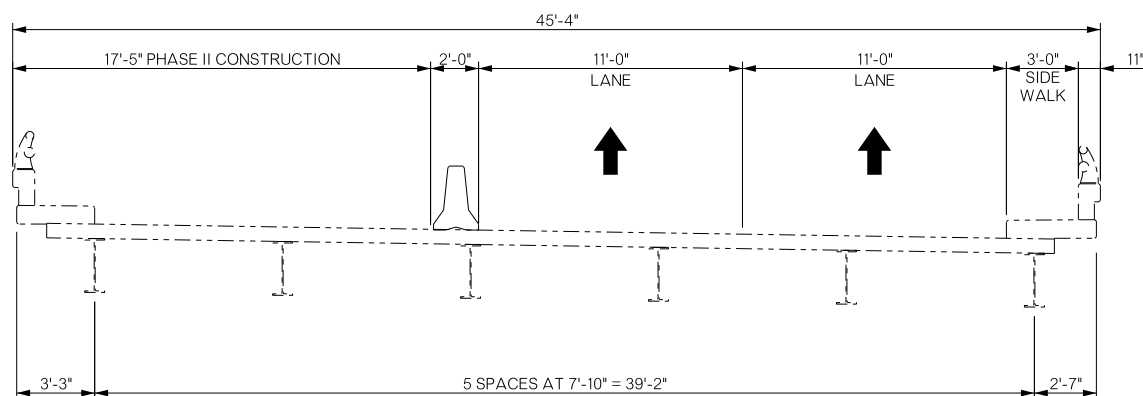

PHASE II

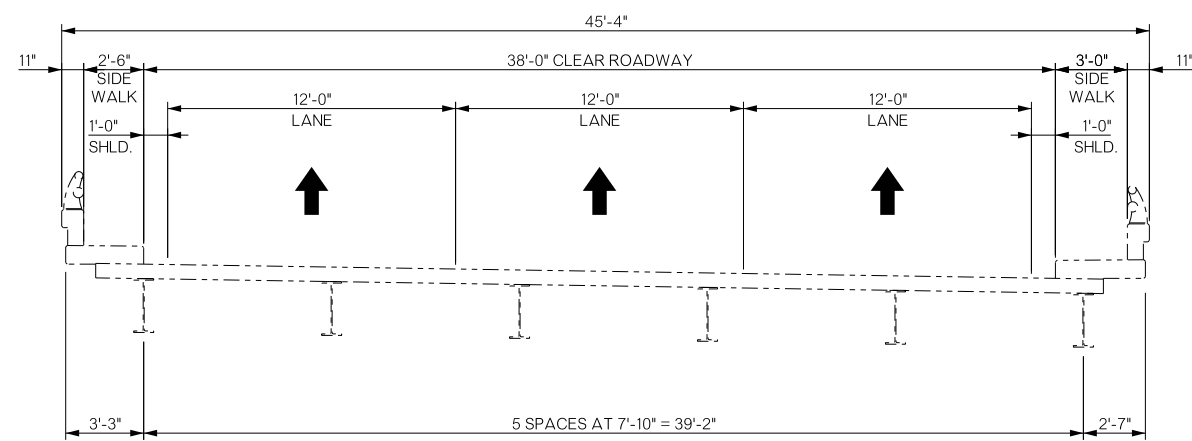

FINISHED BRIDGE

BRIDGE CONSTRUCTION SEQUENCE NOTES

MAINTAIN AT LEAST ONE 11' WIDE LANE OF TRAFFIC AT ALL TIMES.

PHASE I

1. INSTALL PORTABLE LONGITUDINAL BARRIER AND TEMPORARY TRAFFIC CONTROL AS INDICATED.
2. RESTRICT TRAFFIC TO ONE LANE ON THE BRIDGE.
3. PERFORM CLASS B AND C BRIDGE DECK REPAIRS, JOINT REHABILITATION AND EXPANSION JOINT REPLACEMENT.
4. INSTALL NEOPRENE GLANDS FOR THE EXPANSION JOINTS INTO EXTRUSIONS. PROVIDE A CONTINUOUS NEOPRENE GLAND THROUGH THE WIDTH OF THE BRIDGE DECK. DO NOT CUT THE NEOPRENE GLAND BETWEEN PHASES. ROLL UP UNUSED PORTION OF THE GLAND FOR INSTALLATION IN PHASE II.

PHASE II

1. RELOCATE TRAFFIC TO THE REPAIRED PORTION DURING PHASE I.
2. RESTRICT TRAFFIC TO TWO LANES ON THE BRIDGE.
3. PERFORM CLASS B AND C BRIDGE DECK REPAIRS, JOINT REHABILITATION AND EXPANSION JOINT REPLACEMENT.
4. INSTALL REMAINDER OF THE NEOPRENE GLAND FOR EXPANSION JOINTS FROM PHASE I.
5. REMOVE PORTABLE LONGITUDINAL BARRIER.
6. RELOCATE ALL TRAFFIC TO FINAL TRAFFIC CONFIGURATION.

FOR ADDITIONAL DETAILS SEE SHEETS 24-29

NOTE:
EASTBOUND SHOWN; WESTBOUND OPPOSITE HAND

THE CONTRACTOR SHALL COORDINATE ALL WORK WITH CITY OF LAWTON PROJECT PU2202. COORDINATION SHALL INCLUDE THE CITY OF LAWTON, ENGINEER AND CONTRACTOR FOR PROJECT PU2202 AND EN2112.

Design	
Drawn	
Checked	
Approved	
Squad	

CACHE ROAD OVER WOLF CREEK BRIDGES 'A' AND 'B' COMANCHE COUNTY

BRIDGE CONSTRUCTION SEQUENCE

PROJECT DIST NO.	STATE	J.P. PROJECT NO.	FISCAL YEAR	SHEET NO.	TOTAL SHEETS
0001	OKLA	*****	**	---	---

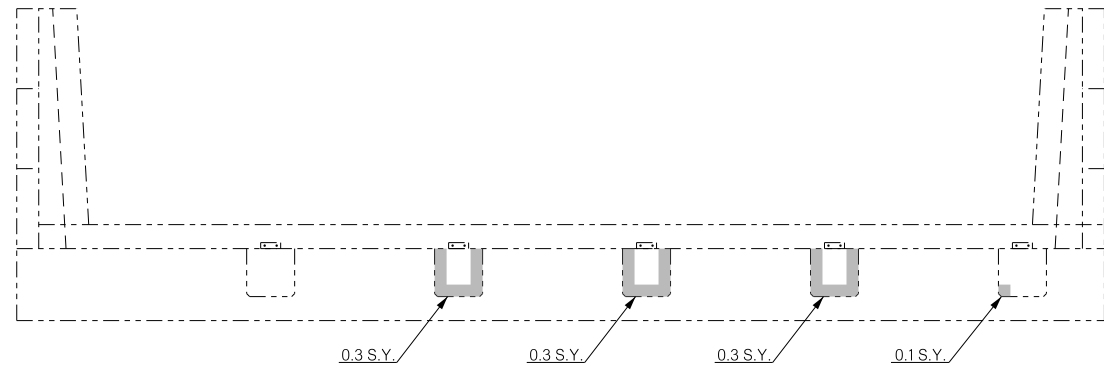

BRIDGE 'B' - EASTBOUND

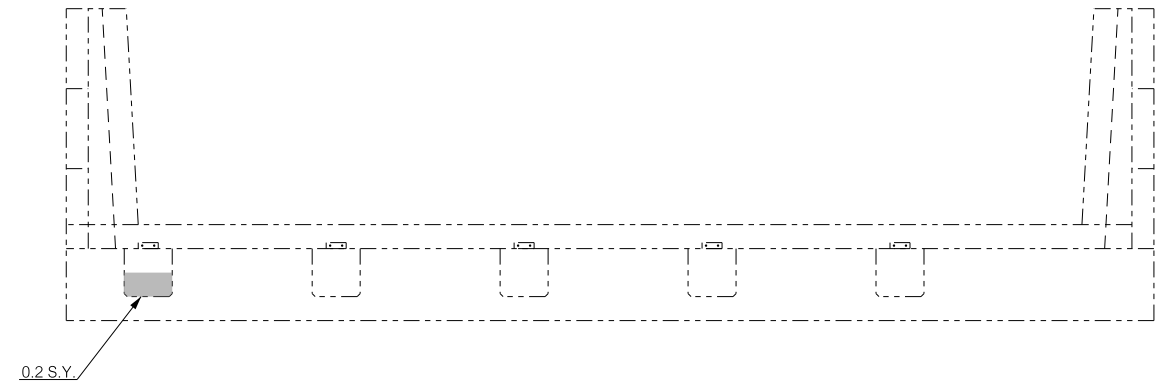

BRIDGE 'A' - WESTBOUND

ABUTMENT NO. 1 PLAN

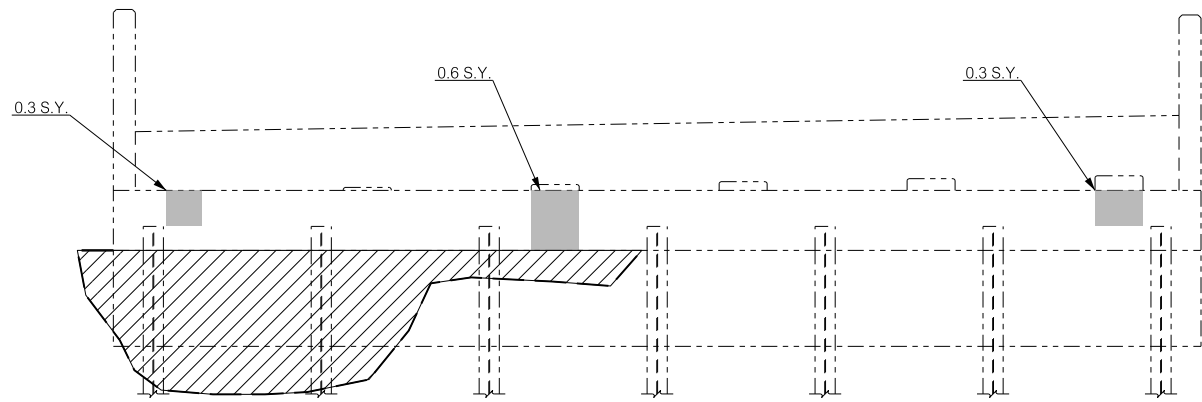

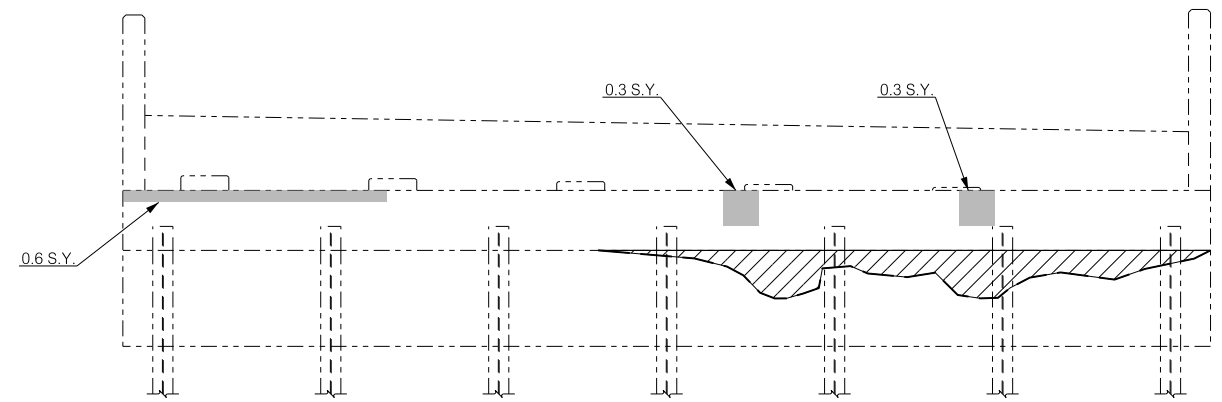

BRIDGE 'B' - EASTBOUND



BRIDGE 'A' - WESTBOUND

ABUTMENT NO. 1 ELEVATION

LEGEND

	CONCRETE REPAIR WITH CORROSION INHIBITOR (SURFACE APPLIED)
	CLSM BACKFILL TO FILL VOID UNDER ABUTMENT SEAT

REPAIR AREAS WERE DETERMINED FROM AN ON-SITE FIELD VISIT HELD ON NOVEMBER 21, 2022. THESE LOCATIONS ARE FOR INFORMATION ONLY TO DETERMINE CALCULATED QUANTITIES. CONCRETE REPAIR AREAS SHALL BE DETERMINED BY THE ENGINEER.

NOTE:
FOR ABUTMENT QUANTITIES AND WATER REPELLENT DETAILS, SEE SHEET 11.
FOR ELASTOMERIC COATING EXTENTS, SEE SHEET 3.

Design		CACHE ROAD OVER WOLF CREEK BRIDGES 'A' AND 'B' ABUTMENT DETAILS ABUTMENT NO. 1 REPAIR DETAILS 1 OF 3 City Project <u>EN2112</u> Sheet No. <u>9</u>
Drawn		
Checked		
Approved		
Squad		

PROJECT DIST NO.	STATE	J.P. PROJECT	FISCAL YEAR	SHEET NO.	TOTAL SHEETS
0001	OKLA	*****	**	10	10

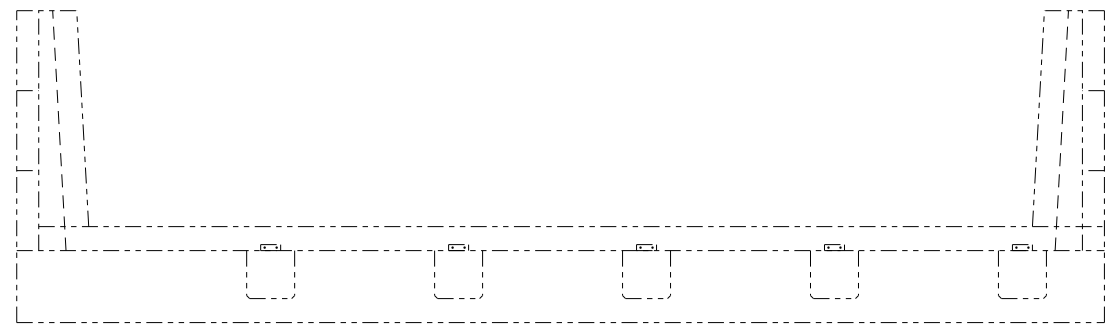

BRIDGE 'A' - WESTBOUND

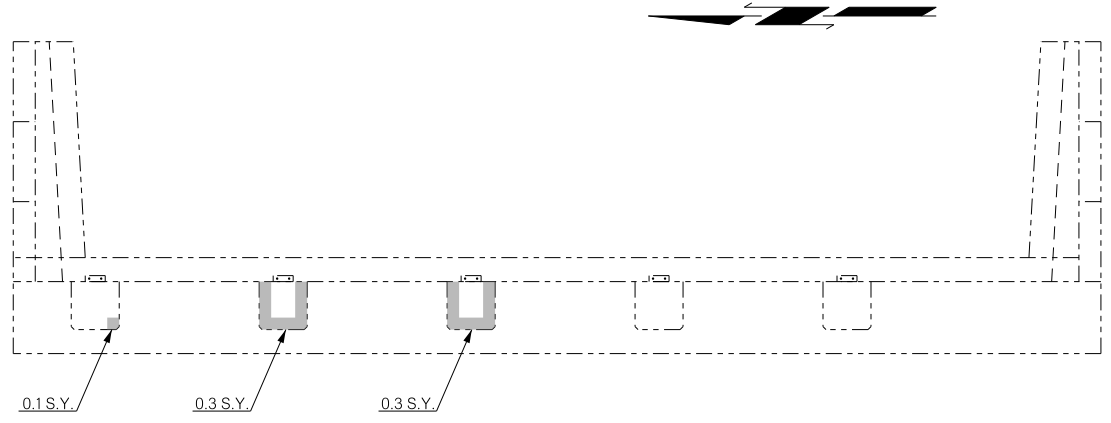

BRIDGE 'B' - EASTBOUND

ABUTMENT NO. 2 PLAN

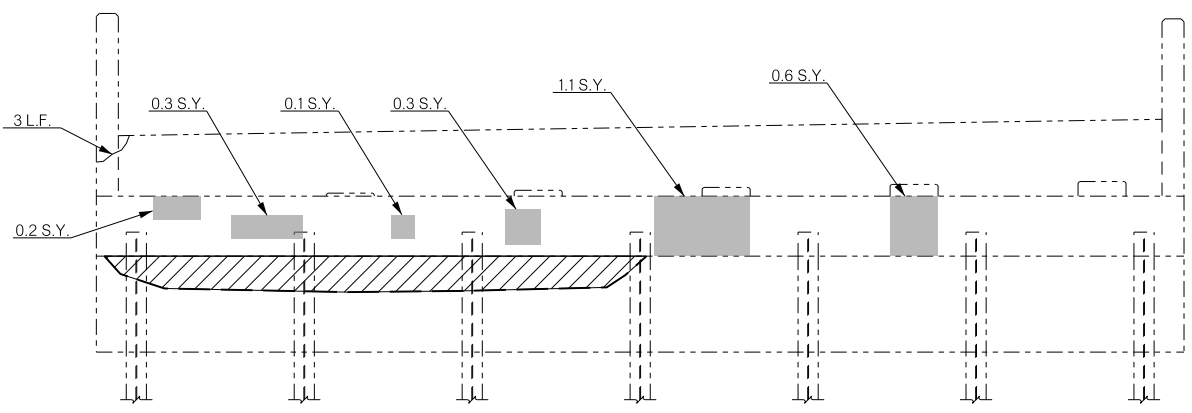

BRIDGE 'A' - WESTBOUND

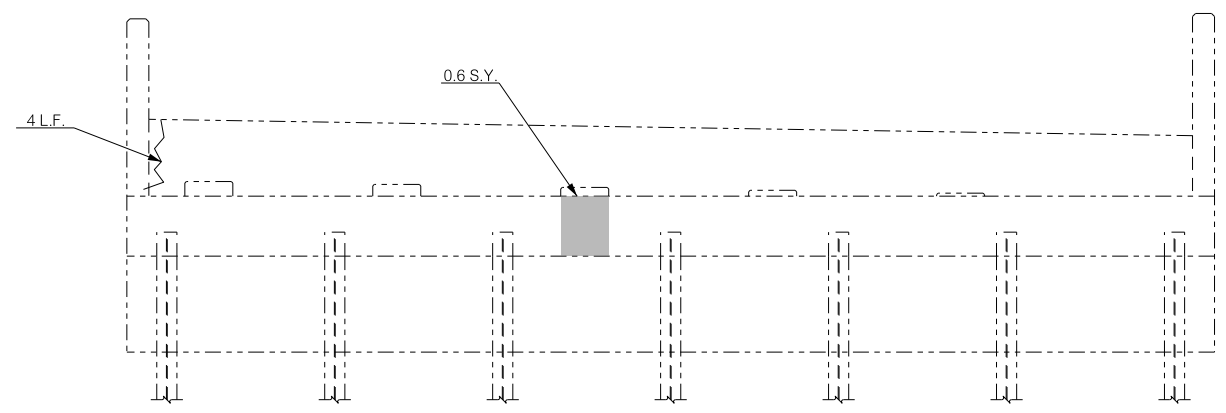

BRIDGE 'B' - EASTBOUND

ABUTMENT NO. 2 ELEVATION

LEGEND

	CONCRETE REPAIR WITH CORROSION INHIBITOR (SURFACE APPLIED)
	PREPARATION OF CRACKS, ABOVE WATER
	CLSM BACKFILL TO FILL VOID UNDER ABUTMENT SEAT

NOTE:
 FOR ABUTMENT QUANTITIES AND WATER REPELLENT DETAILS, SEE SHEET 11.
 FOR ELASTOMERIC COATING EXTENTS, SEE SHEET 3.

REPAIR AREAS WERE DETERMINED FROM AN ON-SITE FIELD VISIT HELD ON NOVEMBER 21, 2022. THESE LOCATIONS ARE FOR INFORMATION ONLY TO DETERMINE CALCULATED QUANTITIES. CONCRETE REPAIR AREAS SHALL BE DETERMINED BY THE ENGINEER.

Design		CACHE ROAD OVER WOLF CREEK BRIDGES 'A' AND 'B' ABUTMENT DETAILS ABUTMENT NO. 2 REPAIR DETAILS 2 OF 3 City Project <u>EN2112</u> Sheet No. <u>10</u>
Drawn		
Checked		
Approved		
Squad		

4/4/2024 4:15:37 PM p:\tochmer-pw_bentley.com\tochmer-pw-01\Documents\Projects\00018888Z_Design\SHEET FILES\0010-ABUTMENT DETAIL.S.dgn

PROJECT DIST NO.	STATE	JEP PROJECT NO.	FISCAL YEAR	SHEET NO.	TOTAL SHEETS
.	OKLA	*****	**		----

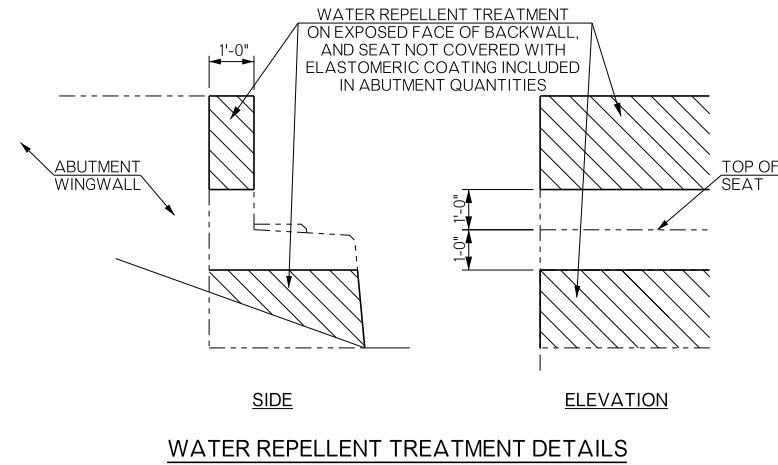

NOTE:
DO NOT APPLY WATER REPELLENT TREATMENT AT AREAS TO RECEIVE ELASTOMERIC COATING.

NOTE:
FOR ELASTOMERIC COATING EXTENTS, SEE SHEET 3.

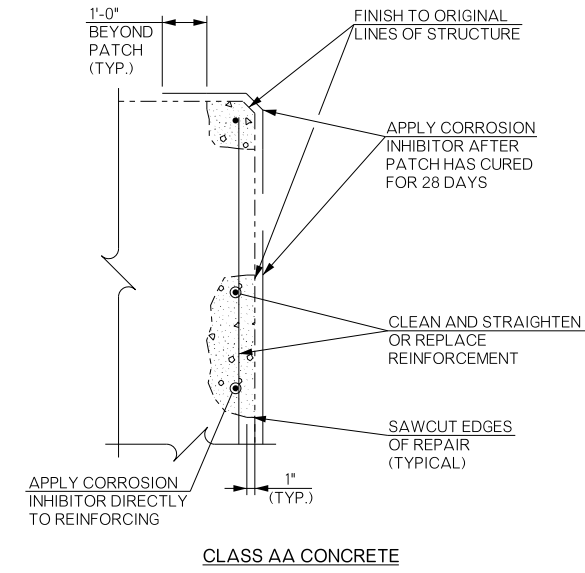
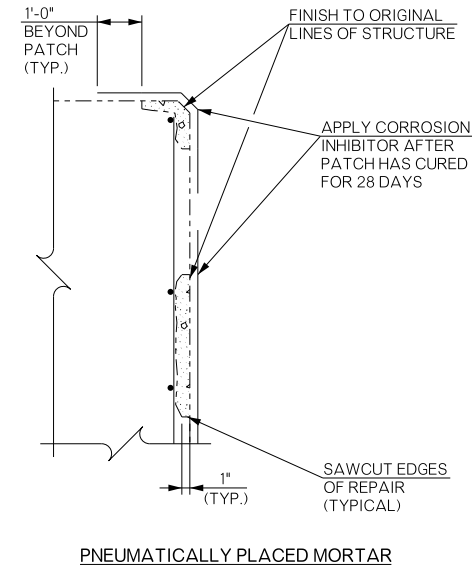

CONCRETE REPAIR DETAILS

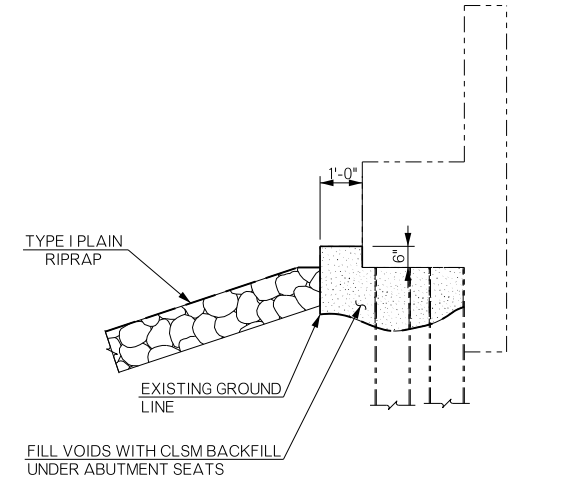

ABUTMENT QUANTITIES							
ITEM	UNIT	BRIDGE 'A' - WESTBOUND			BRIDGE 'B' - EASTBOUND		
		ABUTMENT NO. 1	ABUTMENT NO. 2	TOTAL	ABUTMENT NO. 1	ABUTMENT NO. 2	TOTAL
CLSM BACKFILL	CY	3.70	4.40	8.10	12.50		12.50
ELASTOMERIC COATING	SF	244.00	244.00	488.00	244.00	244.00	488.00
WATER REPELLENT (VISUALLY INSPECTED)	SY	19.00	19.00	38.00	19.00	19.00	38.00
PREPARATION OF CRACKS, ABOVE WATER	LF		3.00	3.00		4.00	4.00
EPOXY RESIN, ABOVE WATER	GAL		0.30	0.30		0.40	0.40
CORROSION INHIBITOR (SURFACE APPLIED)	SY	2.10	3.90	6.00	3.30	2.00	5.30
(PL) REPAIR BRIDGE ITEMS	SY	1.40	2.60	4.00	2.20	1.30	3.50

REPAIR AREAS WERE DETERMINED FROM AN ON-SITE FIELD VISIT HELD ON NOVEMBER 21, 2022. THESE LOCATIONS ARE FOR INFORMATION ONLY TO DETERMINE CALCULATED QUANTITIES. CONCRETE REPAIR AREAS SHALL BE DETERMINED BY THE ENGINEER.

Design		CACHE ROAD OVER WOLF CREEK	COMANCHE COUNTY
Drawn		BRIDGES 'A' AND 'B'	
Checked		ABUTMENT DETAILS	
Approved		ABUTMENT REPAIR DETAILS	
Squad		3 OF 3	

City Project EN2112 Sheet No. 11

PROJECT DIST NO.	STATE	APP. PROJ. NO.	FISCAL YEAR	SHEET NO.	TOTAL SHEETS
..	OKLA	*****	**	---	---

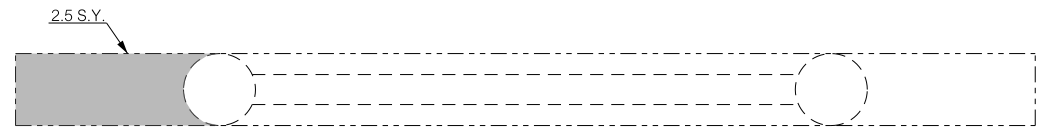

BRIDGE 'B' - EASTBOUND

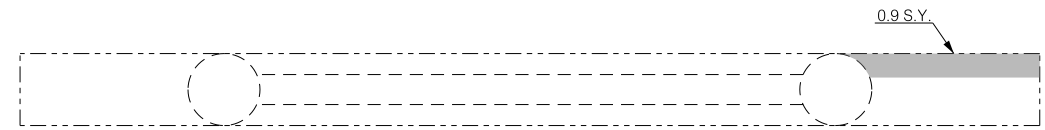

BRIDGE 'A' - WESTBOUND

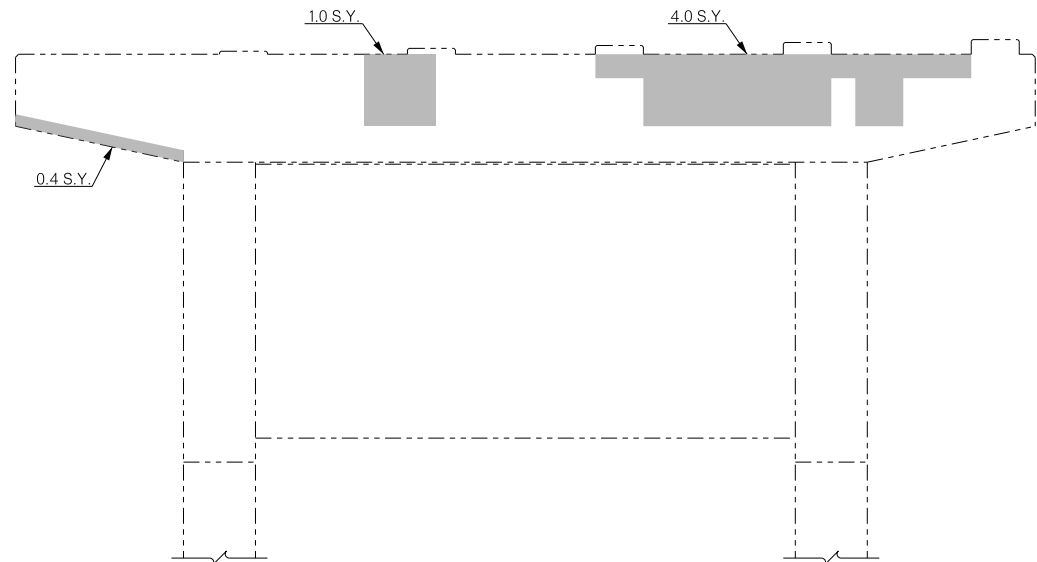

BRIDGE 'A' - WESTBOUND

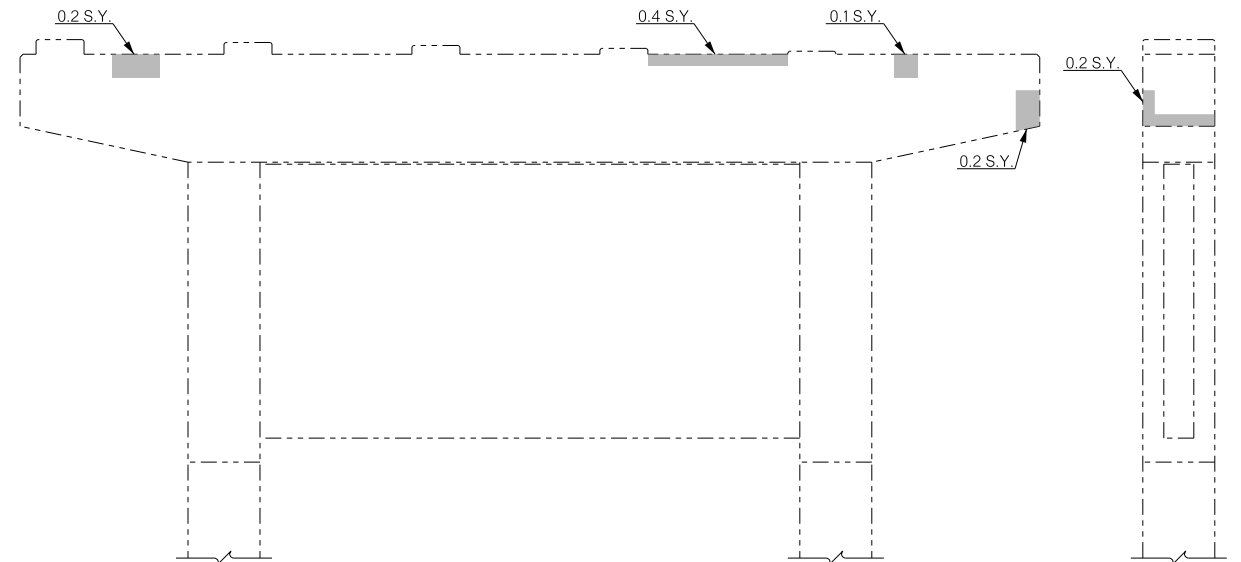

BRIDGE 'B' - EASTBOUND

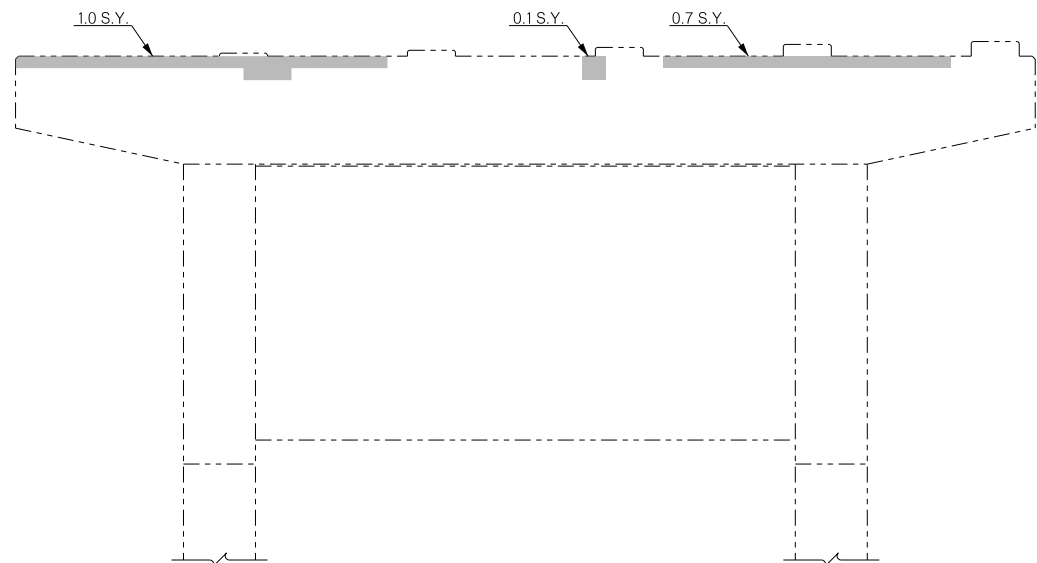

BRIDGE 'B' - EASTBOUND

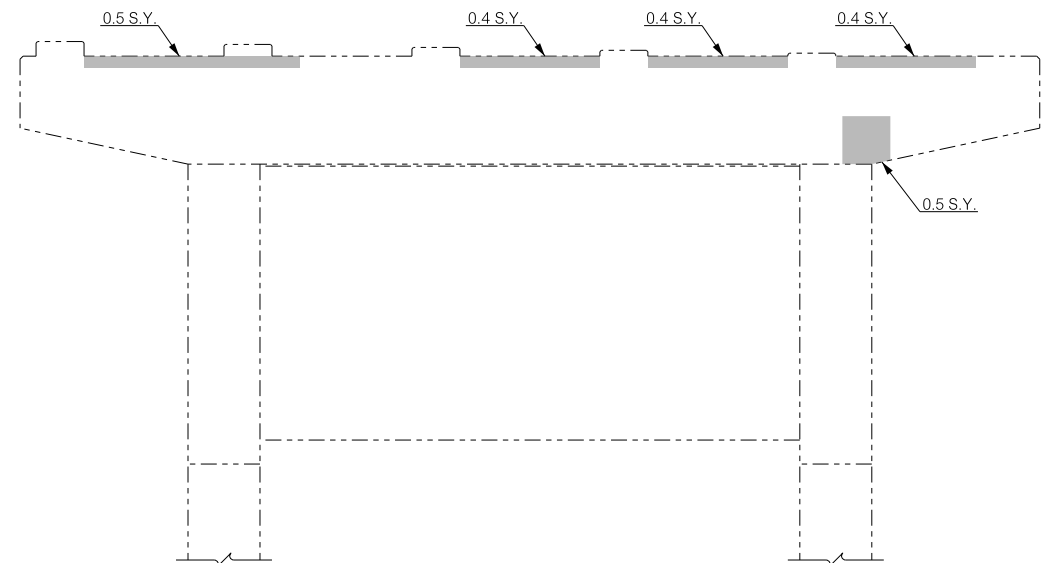

BRIDGE 'A' - WESTBOUND

PIER NO. 1 BOTTOM OF CAP

NOTES:
 FOR ELASTOMERIC COATING EXTENTS, SEE SHEET 3.
 FOR CONCRETE REPAIR DETAILS, SEE SHEET 10.
 FOR WATER REPELLENT TREATMENT DETAIL, SEE SHEET 14.

PIER NO. 1 WEST ELEVATION

LEGEND
 CONCRETE REPAIR WITH CORROSION INHIBITOR (SURFACE APPLIED)

PIER NO. 1 EAST ELEVATION

BRIDGE 'B' - PIER NO. 1 SOUTH ELEVATION

REPAIR AREAS WERE DETERMINED FROM AN ON-SITE FIELD VISIT HELD ON NOVEMBER 21, 2022. THESE LOCATIONS ARE FOR INFORMATION ONLY TO DETERMINE CALCULATED QUANTITIES. CONCRETE REPAIR AREAS SHALL BE DETERMINED BY THE ENGINEER.

Design		CACHE ROAD OVER WOLF CREEK BRIDGES 'A' AND 'B' PIER DETAILS PIER NO. 1 DETAILS 1 OF 3 City Project <u>EN2112</u> Sheet No. <u>12</u>
Drawn		
Checked		
Approved		
Squad		

PROJECT DIST NO.	STATE	J.P. PROJECT NO.	FISCAL YEAR	SHEET NO.	TOTAL SHEETS
*	OKLA	*****	**		----

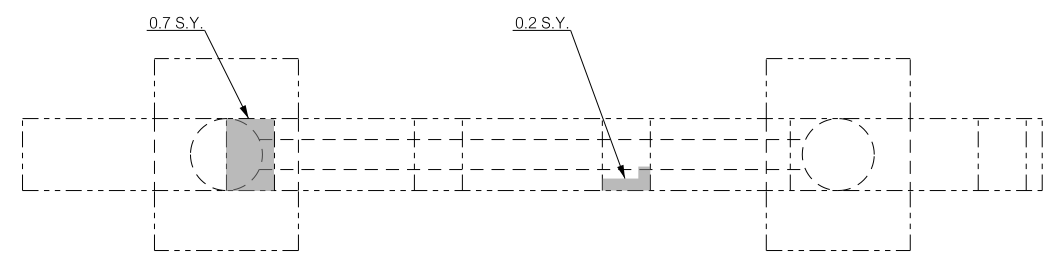

BRIDGE 'A' - WESTBOUND

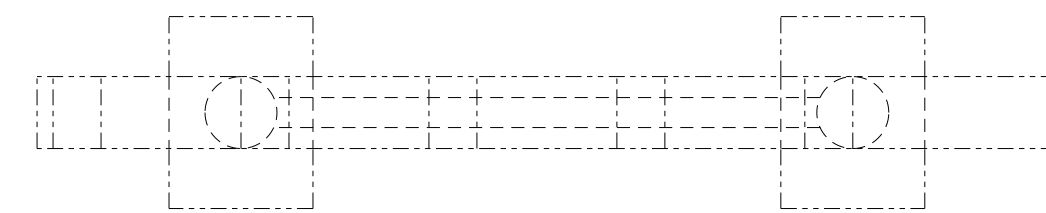

BRIDGE 'B' - EASTBOUND

PIER NO. 2 PLAN

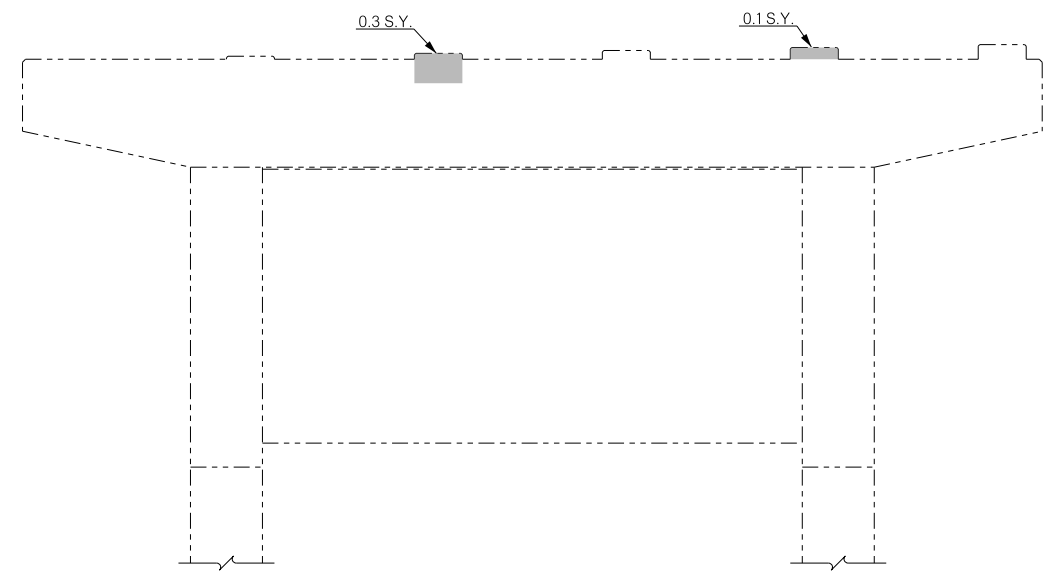

BRIDGE 'A' - WESTBOUND

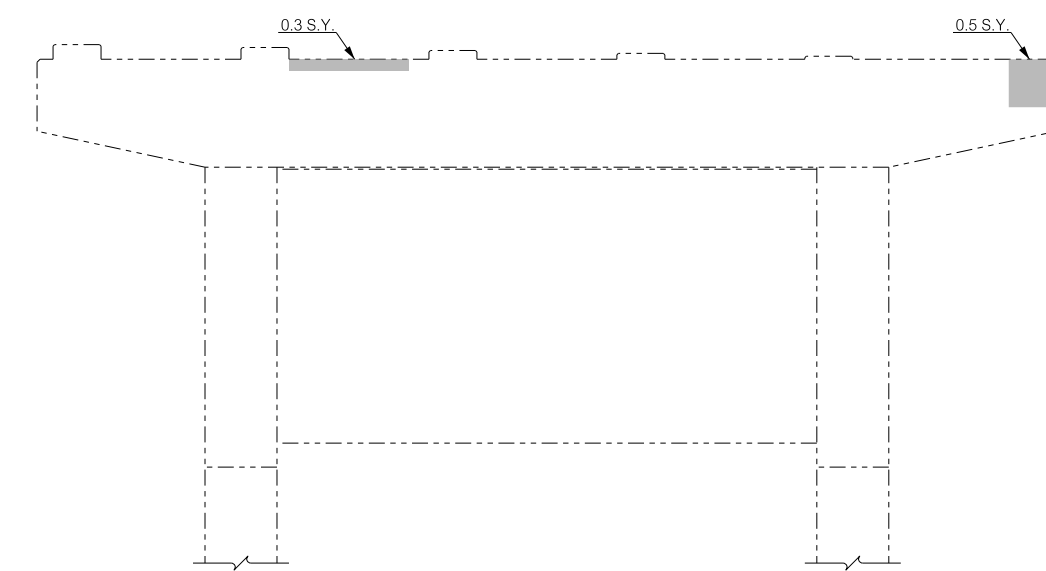

BRIDGE 'B' - EASTBOUND

NOTES:
 FOR ELASTOMERIC COATING EXTENTS, SEE SHEET 3.
 FOR CONCRETE REPAIR DETAILS, SEE SHEET 10.
 FOR WATER REPELLENT TREATMENT DETAIL, SEE SHEET 14.

PIER NO. 2 WEST ELEVATION

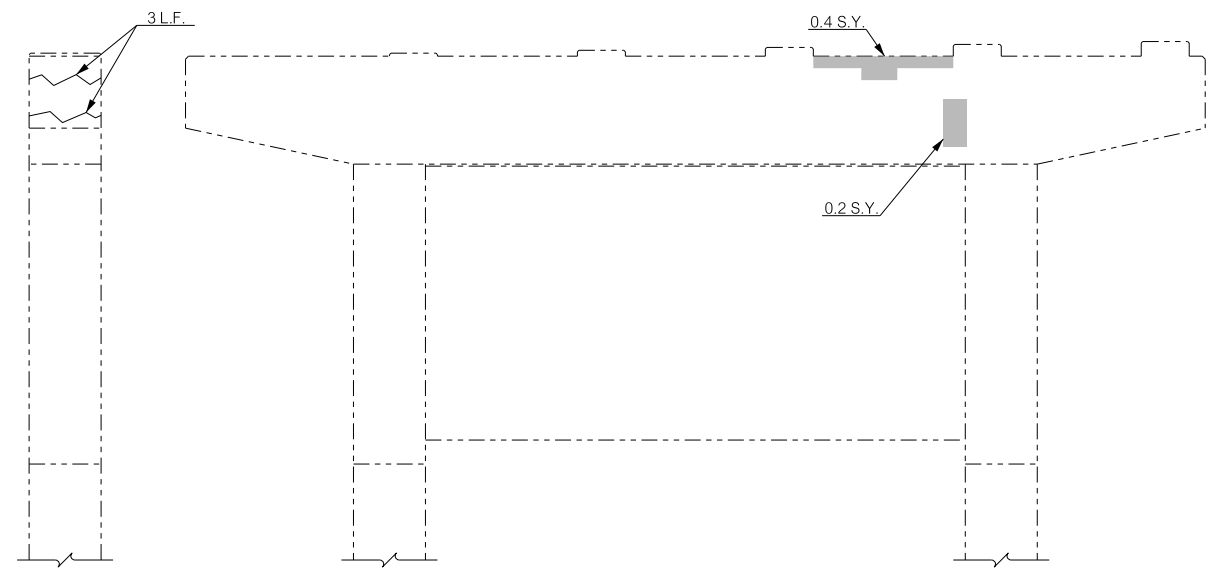

BRIDGE 'B' - PIER NO. 2 SOUTH ELEVATION

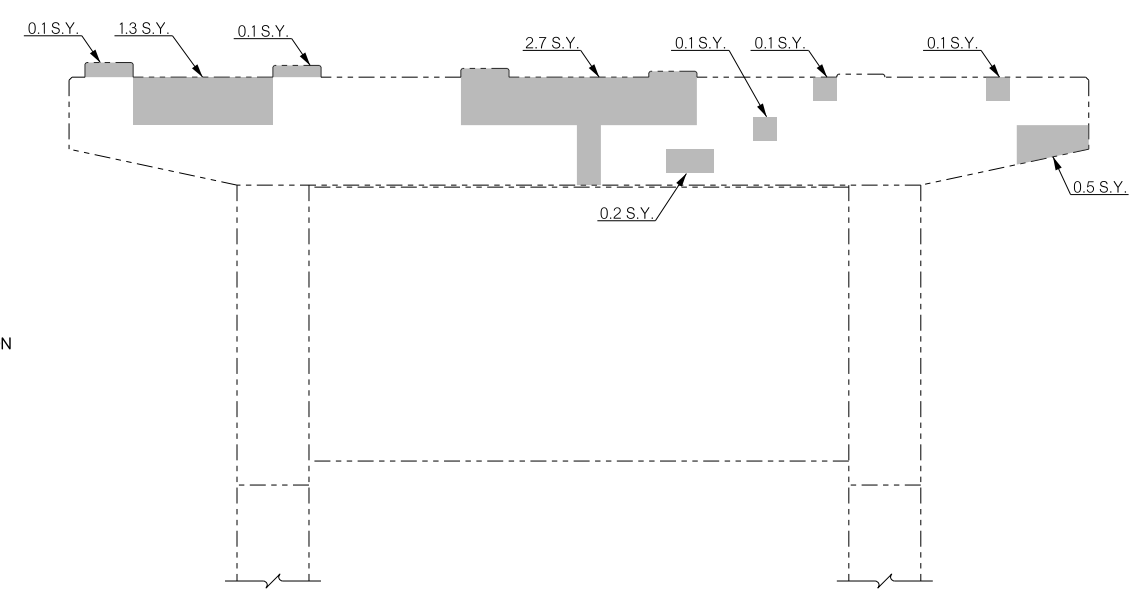

BRIDGE 'A' - WESTBOUND

PIER NO. 2 EAST ELEVATION

LEGEND

CONCRETE REPAIR WITH CORROSION INHIBITOR (SURFACE APPLIED)

PREPARATION OF CRACKS, ABOVE WATER

REPAIR AREAS WERE DETERMINED FROM AN ON-SITE FIELD VISIT HELD ON NOVEMBER 21, 2022. THESE LOCATIONS ARE FOR INFORMATION ONLY TO DETERMINE CALCULATED QUANTITIES. CONCRETE REPAIR AREAS SHALL BE DETERMINED BY THE ENGINEER.

Design		CACHE ROAD OVER WOLF CREEK	COMANCHE COUNTY
Drawn		BRIDGES 'A' AND 'B'	
Checked		PIER DETAILS PIER NO. 2 DETAILS 2 OF 3	
Approved			
Squad			
		City Project	EN2112
		Sheet No.	13

PROJECT DIST NO.	STATE	J.P. PROJECT	FISCAL YEAR	SHEET NO.	TOTAL SHEETS
*	OKLA	*****	**		----

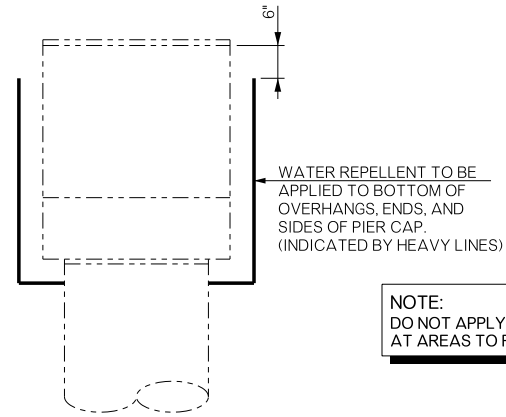

NOTE:
DO NOT APPLY WATER REPELLENT TREATMENT AT AREAS TO RECEIVE ELASTOMERIC COATING.

NOTES:
FOR ELASTOMERIC COATING EXTENTS, SEE SHEET 3.
FOR CONCRETE REPAIR LOCATIONS, SEE SHEET 12 & 13.

WATER REPELLENT TREATMENT DETAIL

PIER QUANTITIES							
ITEM	UNIT	BRIDGE 'A' - WESTBOUND			BRIDGE 'B' - EASTBOUND		
		PIER NO. 1	PIER NO. 2	TOTAL	PIER NO. 1	PIER NO. 2	TOTAL
ELASTOMERIC COATING	SF	191.00	191.00	382.00	191.00	191.00	382.00
WATER REPELLENT (VISUALLY INSPECTED)	SY	42.00	42.00	84.00	42.00	42.00	84.00
PREPARATION OF CRACKS, ABOVE WATER	LF			0.00		6.00	6.00
EPOXY RESIN, ABOVE WATER	GAL			0.00		0.50	0.50
CORROSION INHIBITOR (SURFACE APPLIED)	SY	12.80	9.80	22.60	8.10	2.10	10.20
(PL) REPAIR BRIDGE ITEMS	SY	8.50	6.50	15.00	5.40	1.40	6.80

REPAIR AREAS WERE DETERMINED FROM AN ON-SITE FIELD VISIT HELD ON NOVEMBER 21, 2022. THESE LOCATIONS ARE FOR INFORMATION ONLY TO DETERMINE CALCULATED QUANTITIES. CONCRETE REPAIR AREAS SHALL BE DETERMINED BY THE ENGINEER.

Design		CACHE ROAD OVER WOLF CREEK	COMANCHE COUNTY
Drawn		BRIDGES 'A' AND 'B'	
Checked		PIER DETAILS	
Approved		PIER REPAIR DETAILS	
Squad		3 OF 3	
		City Project	EN2112
		Sheet No.	14

4/4/2024

4:16:17 PM

p:\p\tochner-pw_bentley.com\tochner-pw-01\Documents\Projects\00018888Z_Design\SHEET FILES\014-PIER DETAILS.dgn

PROJECT DIST NO.	STATE	JEP PROJ NO.	FISCAL YEAR	SHEET NO.	TOTAL SHEETS
OKLA	OKLA	*****	..	---	---

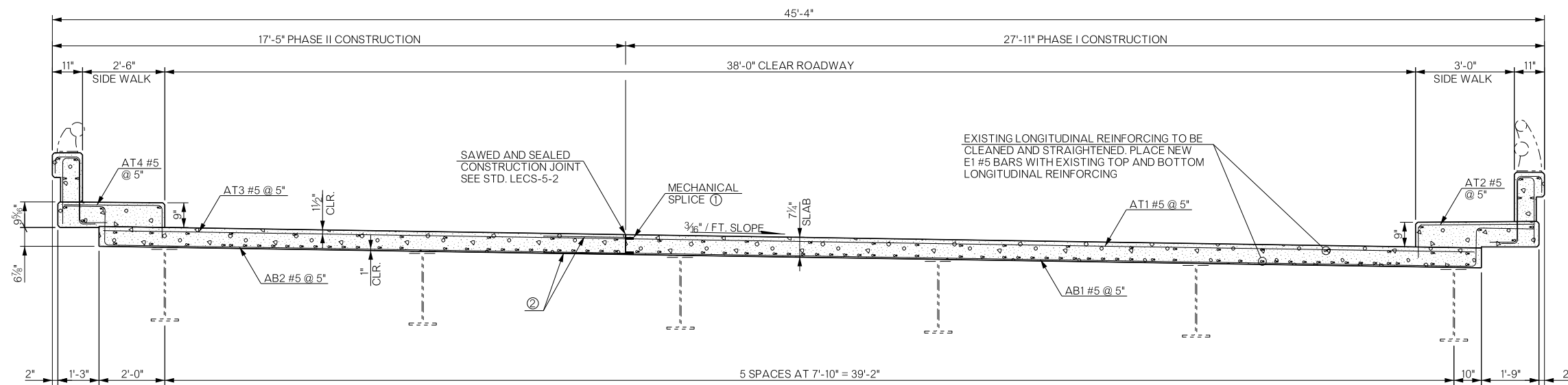

TYPICAL SLAB REPLACEMENT SECTION

EXISTING LONGITUDINAL REINFORCING TO BE CLEANED AND STRAIGHTENED. PLACE NEW E1 #5 BARS WITH EXISTING LONGITUDINAL REINFORCING

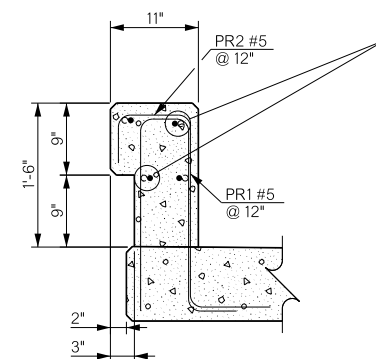

PARAPET DETAIL

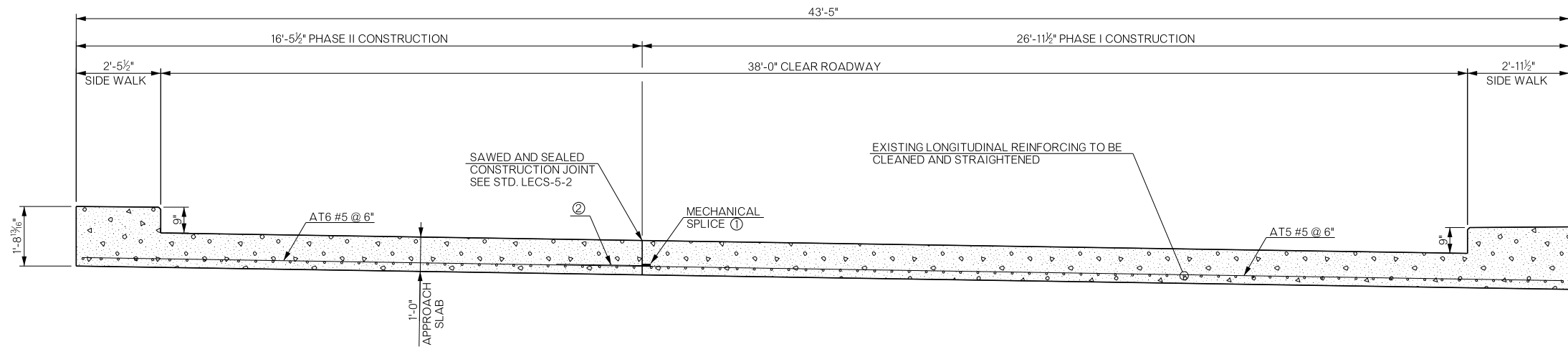

TYPICAL APPROACH SLAB REPLACEMENT SECTION

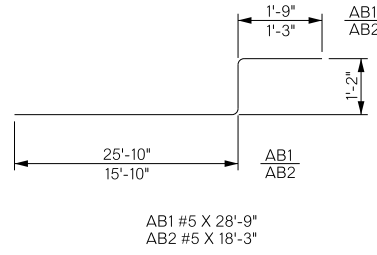
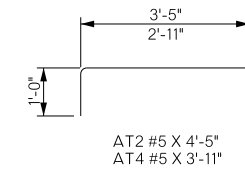
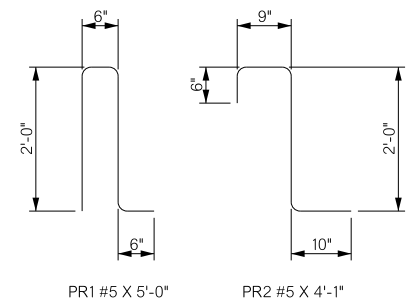

CONTRACTOR SHALL MAINTAIN THE EXISTING FINISHED GRADE ALONG THE BRIDGE DECK AT ALL PANEL REPLACEMENT LOCATIONS

- ① EPOXY COAT OR GALVANIZE MECHANICAL SPLICE.
- ② PROVIDE #5 EPOXY COATED REBAR TO PROVIDE A MINIMUM LAP OF 2'-6" WITH AT BARS FOR EACH PHASE AT EACH MECHANICAL SPLICE. INCLUDE ALL COST FOR THE EPOXY COATED REBAR, LABOR, AND INCIDENTALS IN THE CONTRACT UNIT PRICE OF "MECHANICAL SPLICE".

NOTE: EASTBOUND SHOWN; WESTBOUND OPPOSITE HAND

ITEM	UNIT	SUPERSTRUCTURE QUANTITIES					
		BRIDGE 'A' - WESTBOUND			BRIDGE 'B' - EASTBOUND		
		PHASE I	PHASE II	TOTAL	PHASE I	PHASE II	TOTAL
SAW-CUT GROOVING	SY	32.00	18.70	50.70	32.00	18.70	50.70
HANGERS	EA						10.00
CONCRETE PARAPET	LF	42.00	42.00	84.00	42.00	42.00	84.00
STRUCTURAL STEEL	LB	30.00	20.00	50.00	30.00	20.00	50.00
WEATHERING STEEL EXPANSION BEARING ASSEMBLY	EA			6.00			4.00
CLASS AA CONCRETE	CY	36.20	23.40	59.60	36.20	23.40	59.60
MECHANICAL SPLICES	EA	220.00		220.00	220.00		220.00
EPOXY COATED REINFORCING STEEL	LB	9,980.00	6,500.00	16,480.00	9,980.00	6,500.00	16,480.00
PAINTING EXISTING STRUCTURES	LSUM			1.00			1.00
COLLECTION AND HANDLING WASTE	LSUM			1.00			1.00
CLASS B BRIDGE DECK REPAIR	SY	18.70	4.20	22.90	39.10	24.00	63.10
WATER REPELLENT (VISUALLY INSPECTED)	SY	104.00	96.00	200.00	104.00	96.00	200.00
SEALED EXPANSION JOINT	LF	52.00	32.00	84.00	52.00	32.00	84.00
RAPID CURE JOINT SEALANT	LF	50.00	27.50	83.50	56.00	27.50	83.50
DECK AREA SEALED (FLOODCOATS)	SY	511.00	298.00	809.00	511.00	298.00	809.00

Design		CACHE ROAD OVER WOLF CREEK BRIDGES 'A' AND 'B' SUPERSTRUCTURE DETAILS TYPICAL SECTION 1 OF 8 City Project EN2112 Sheet No. 15
Drawn		
Checked		
Approved		
Squad		

PROJECT DIST NO.	STATE	APP. PROJ. NO.	FISCAL YEAR	SHEET NO.	TOTAL SHEETS
.	OKLA	*****	**		----

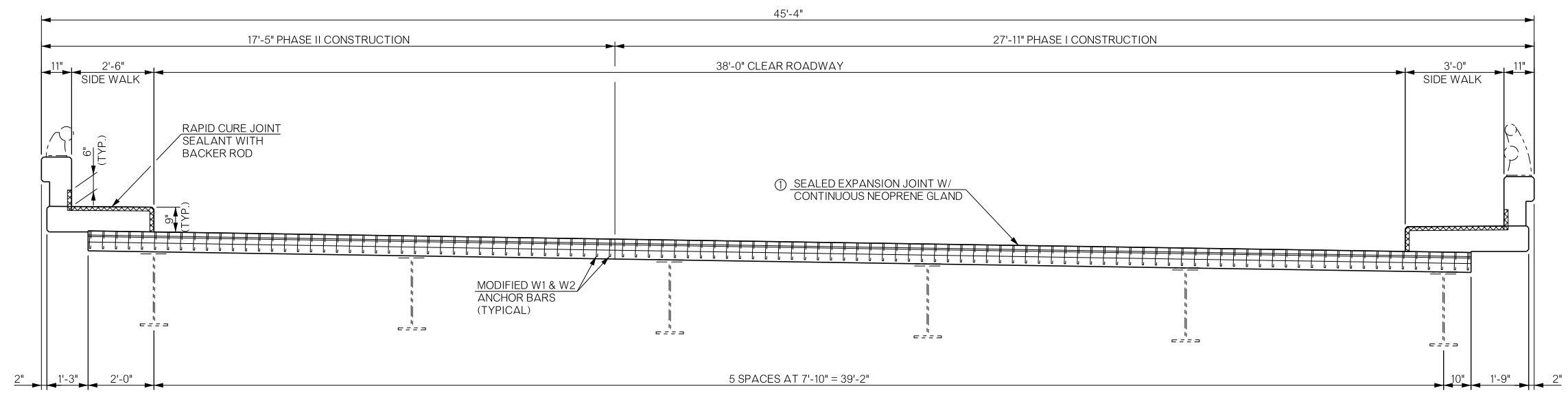
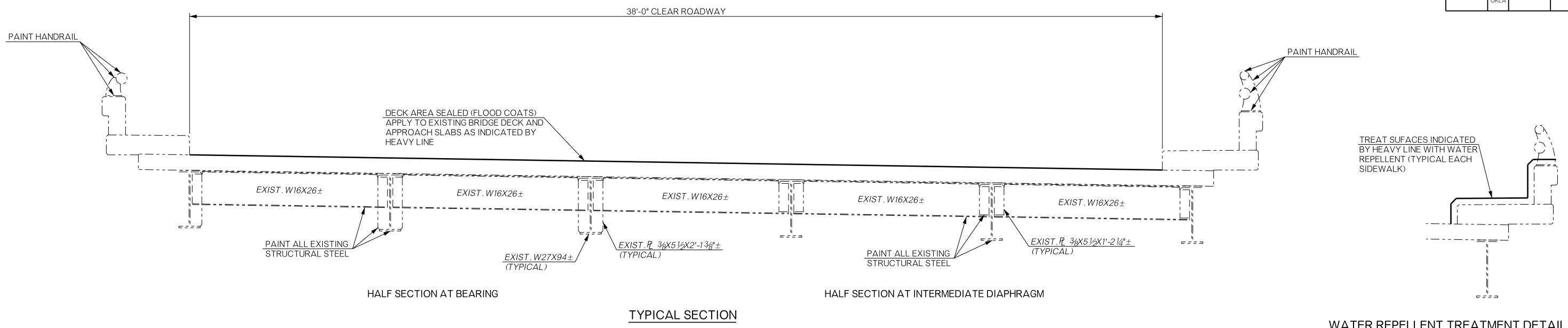

① ITEM "SEALED EXPANSION JOINTS" WILL BE FABRICATED AND INSTALLED IN TWO PHASES. DURING THE SECOND PHASE OF CONSTRUCTION, THE DEVICE ANGLES OF THE SECOND PHASE WILL BE ALIGNED WITH THE FIRST PHASE ANGLES AND PROPERLY SUPPORTED DURING POURING OF THE CONCRETE. THE NEOPRENE GLAND WILL BE FURNISHED FULL LENGTH OF THE COMPLETED EXPANSION JOINT AND WILL BE CONTINUOUS ACROSS THE ENTIRE WIDTH OF THE EXPANSION JOINT ALONG THE BRIDGE DECK, CURB FACE, SIDEWALK AND INTO THE PARAPET. THE END OF THE NEOPRENE GLAND INSTALLED IN THE PHASE I JOINT WILL BE ROLLED UP AND PROTECTED UNTIL IT CAN BE INSTALLED IN PHASE II.

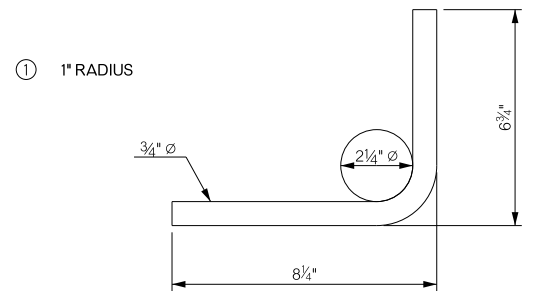
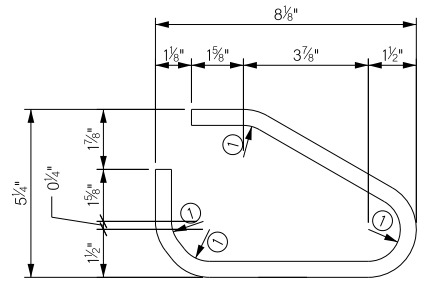
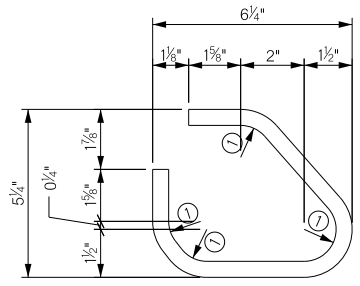

Design		CACHE ROAD OVER WOLF CREEK BRIDGES 'A' AND 'B' SUPERSTRUCTURE DETAILS TYPICAL SECTION 2 OF 8	COMANCHE COUNTY
Drawn			
Checked			
Approved			
Squad			
City Project		EN2112	Sheet No. 16

PROJECT DIST NO.	STATE	J.P. PROJECT NO.	FISCAL YEAR	SHEET NO.	TOTAL SHEETS
...	OKLA

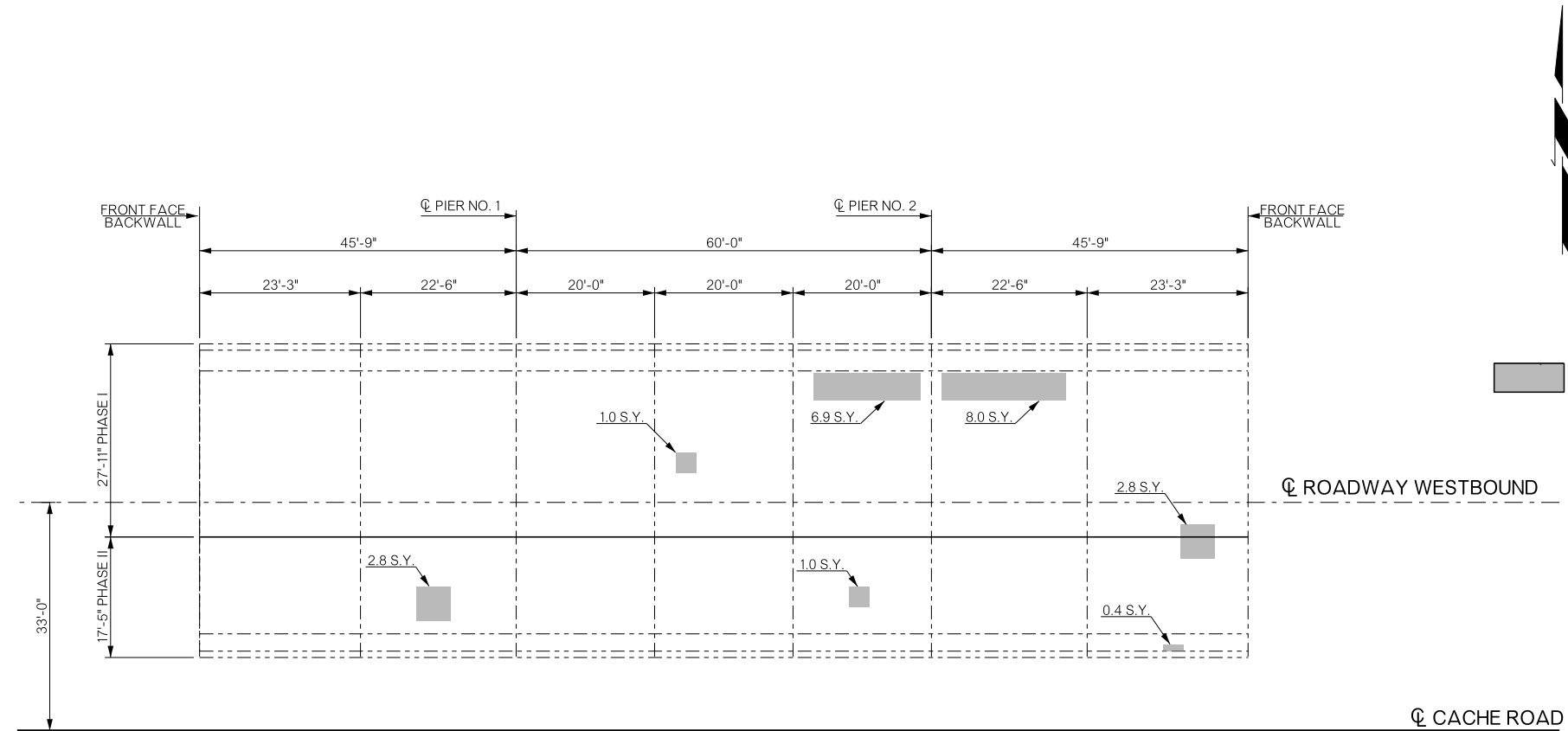

LEGEND
 CLASS B BRIDGE DECK REPAIR

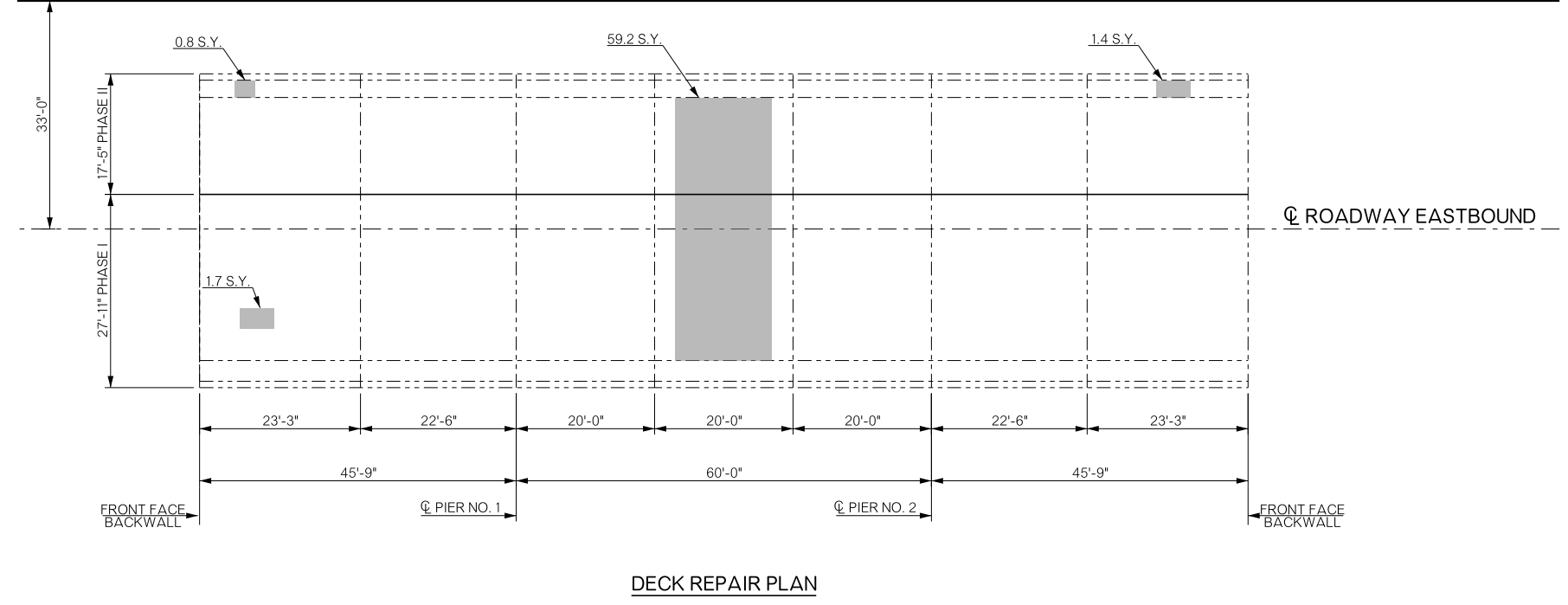
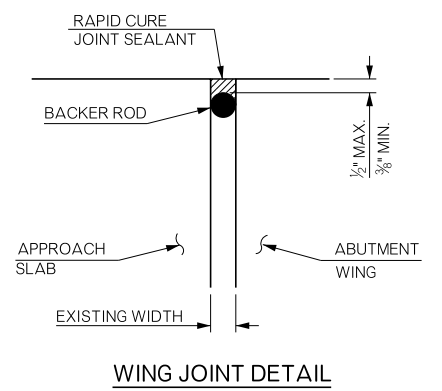

DECK REPAIR PLAN

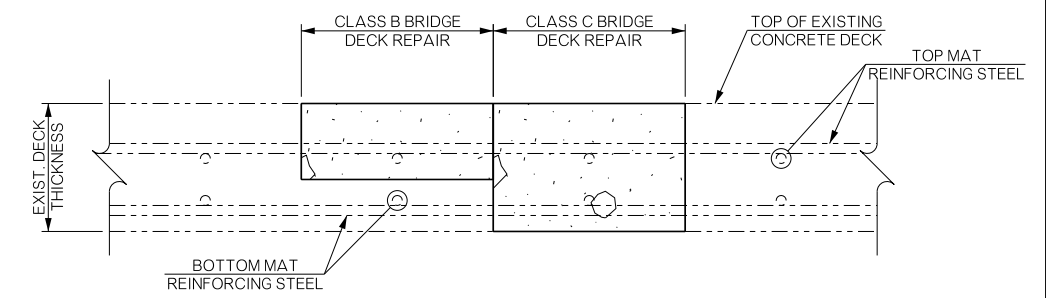

BRIDGE DECK REPAIR DETAIL

Design		CACHE ROAD OVER WOLF CREEK BRIDGES 'A' AND 'B' SUPERSTRUCTURE DETAILS 3 OF 8 City Project <u>EN2112</u> Sheet No. <u>17</u>	COMANCHE COUNTY
Drawn			
Checked			
Approved			
Squad			

4/4/2024 4:16:42 PM p:\tochnr-pw_bentley.com\tochnr-pw-01\Documents\Projects\00018888Z_Design\SHEET FILES\0017-SUPERSTRUCTURE DETAILS.dgn

PROJECT DIST NO.	STATE	J.P. PROJECT NO.	FISCAL YEAR	SHEET NO.	TOTAL SHEETS
00018888Z	OKLA	*****	**	18	20

LEGEND
 REMOVAL

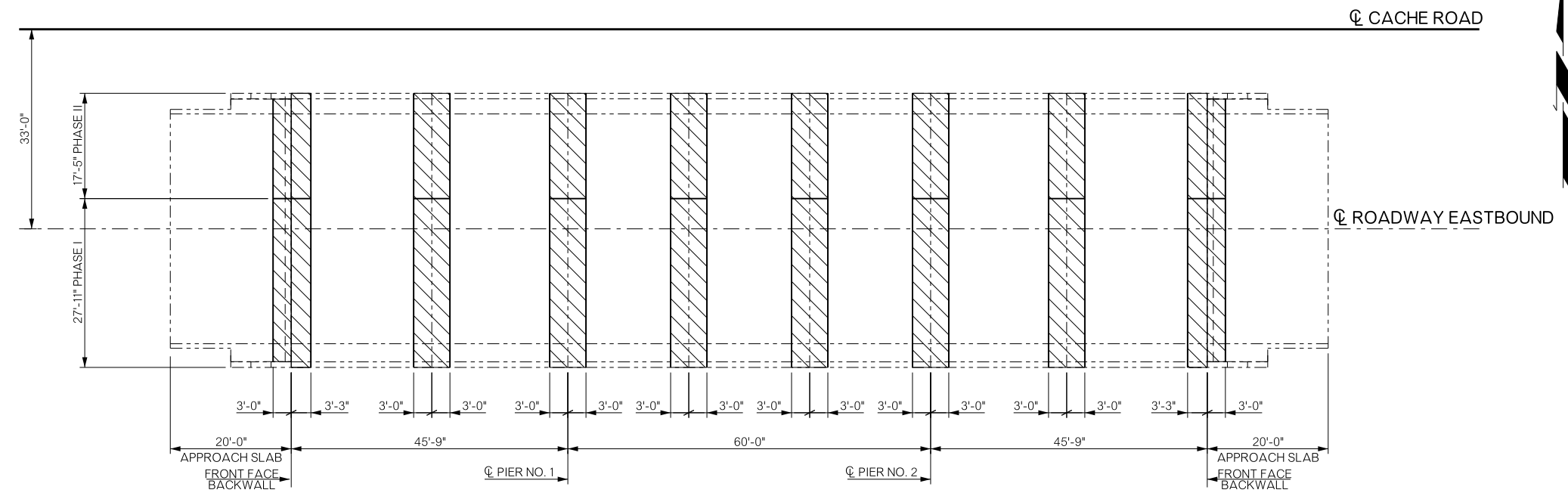

REMOVAL PLAN

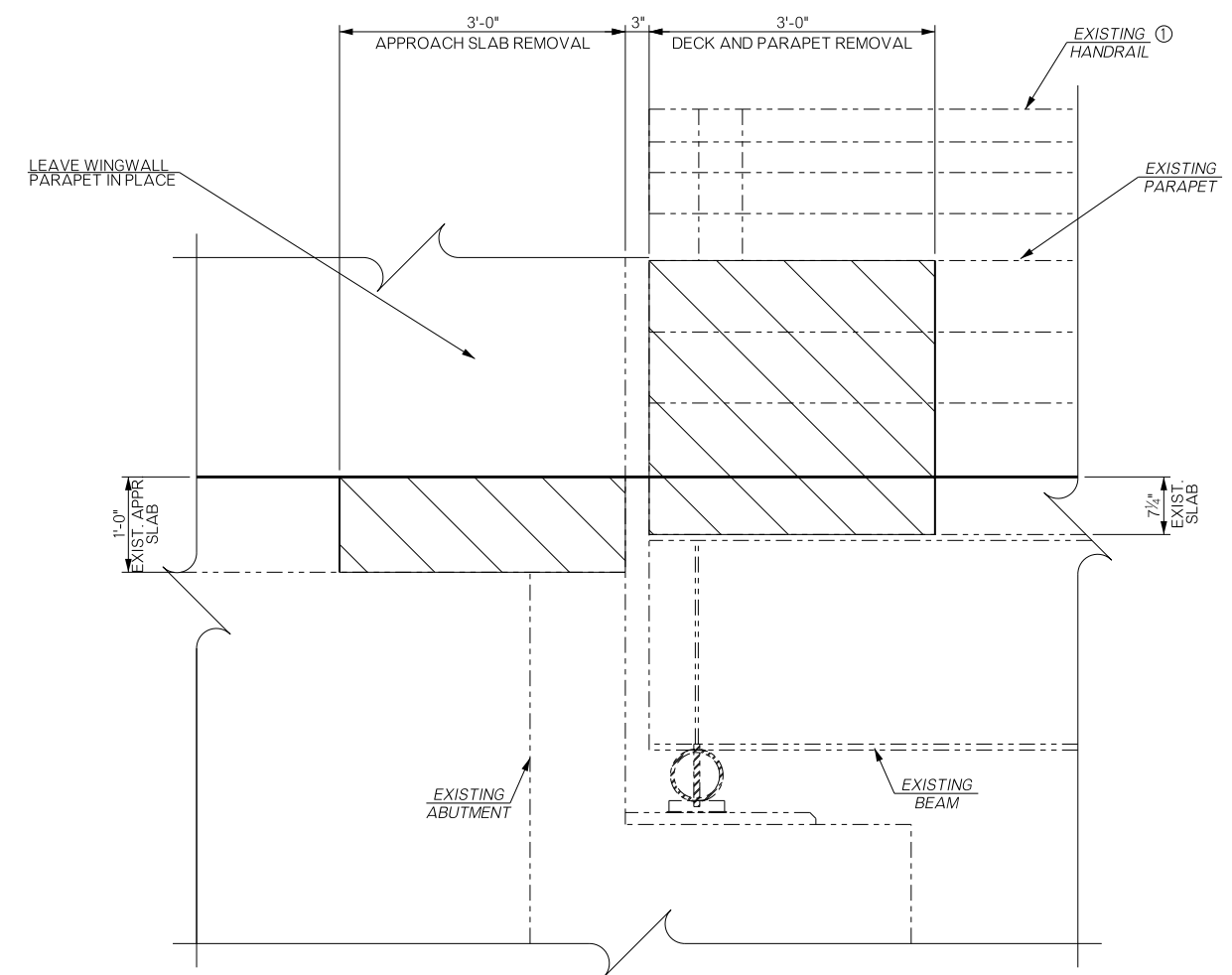

SLAB REMOVAL AT ABUTMENT

① PROTECT IN PLACE. SUPPORT HANDRAIL DURING REMOVAL AND CONSTRUCTION OPERATIONS.

NOTE: EASTBOUND SHOWN; WESTBOUND SIMILAR

NOTE: DIMENSIONS ARE ALONG ϕ BEAM. ABUTMENT NO. 1 SHOWN; ABUTMENT NO. 2 OPPOSITE HAND.

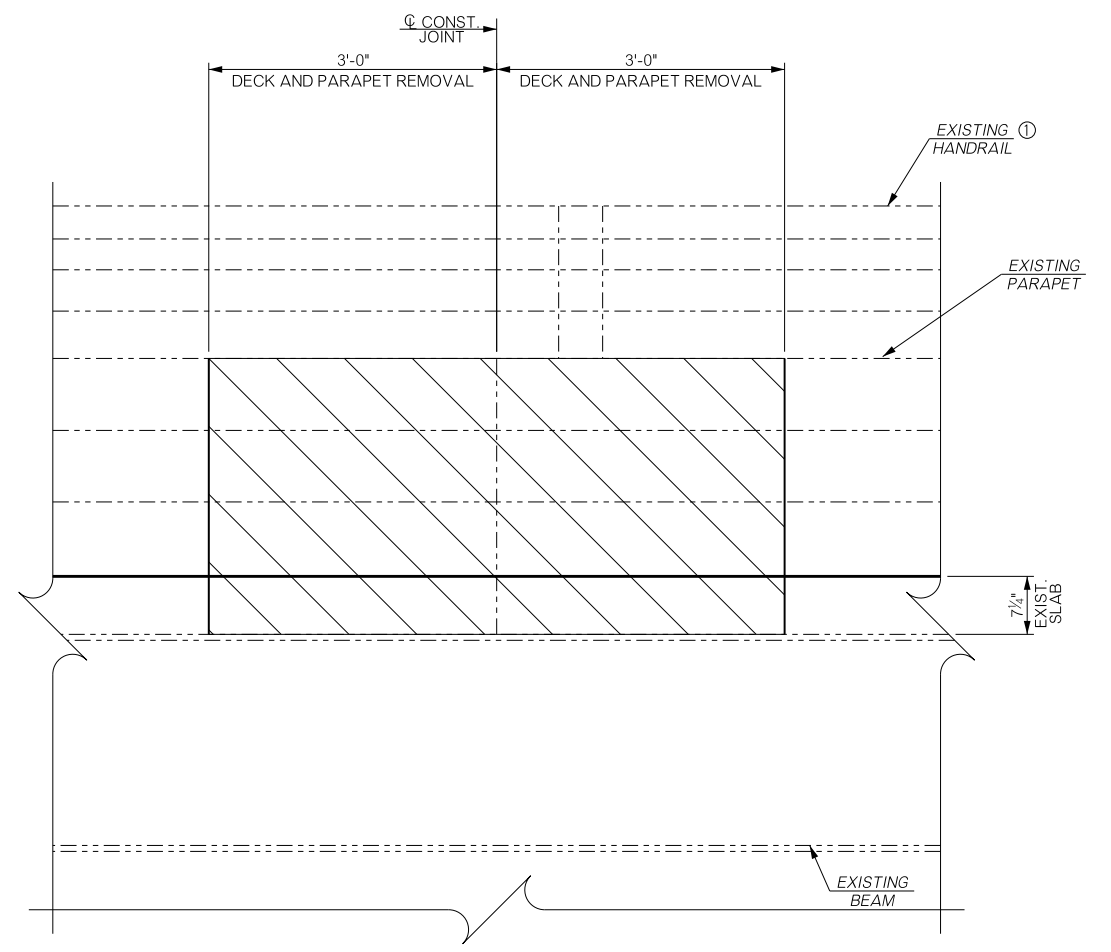

SLAB REMOVAL AT CONSTRUCTION JOINT

Design	
Drawn	
Checked	
Approved	
Squad	

CACHE ROAD OVER WOLF CREEK BRIDGES 'A' AND 'B' COMANCHE COUNTY
SUPERSTRUCTURE DETAILS
 SLAB REMOVAL DETAILS
 4 OF 8
 City Project EN2112 Sheet No. 18

PROJECT DIST NO.	STATE	J.P. PROJECT NO.	FISCAL YEAR	SHEET NO.	TOTAL SHEETS
...	OKLA

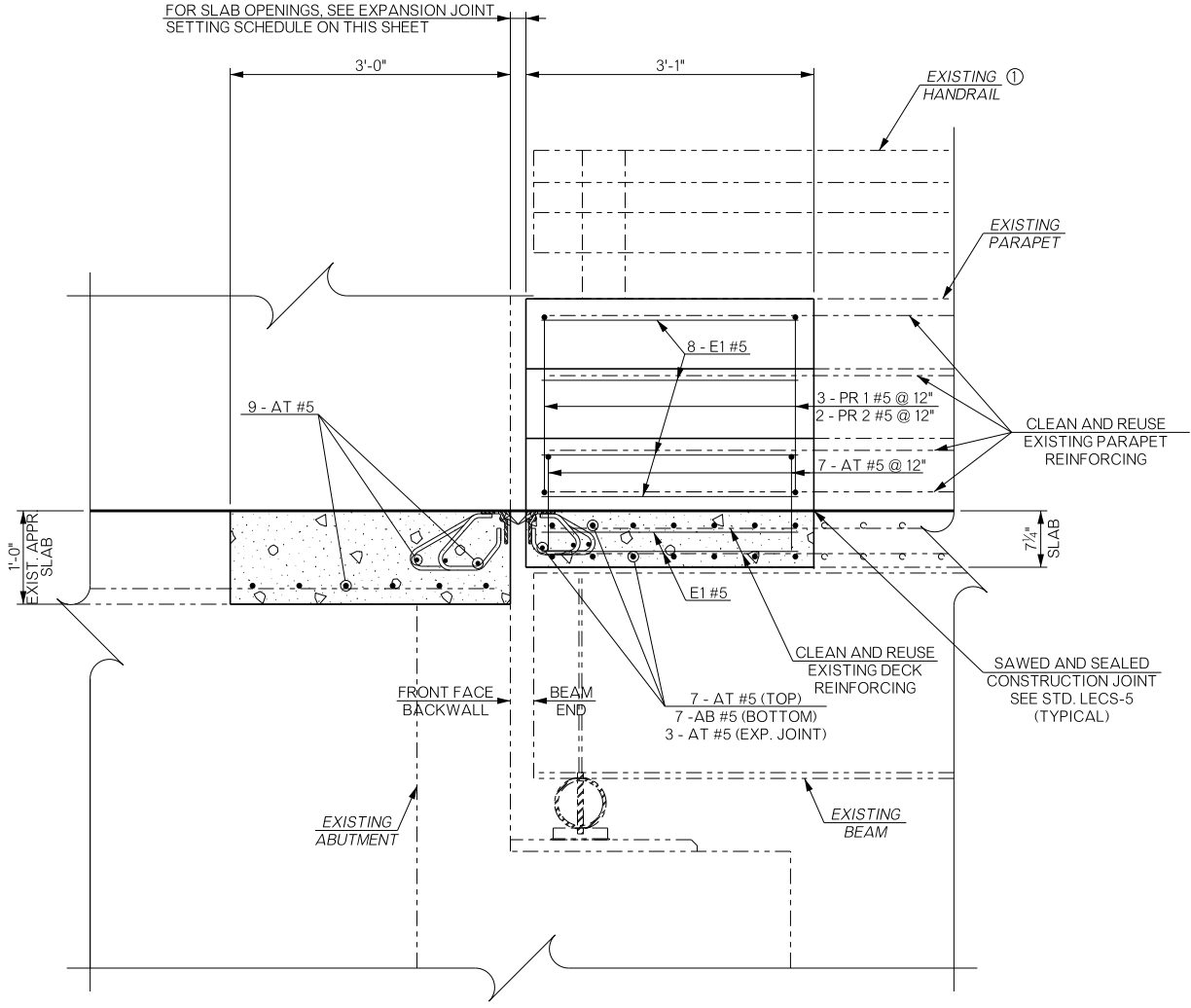

SLAB REPLACEMENT DETAIL AT PARAPET

① PROTECT IN PLACE. SUPPORT HANDRAIL DURING REMOVAL AND CONSTRUCTION OPERATIONS.

CONTRACTOR SHALL MAINTAIN THE EXISTING FINISHED GRADE ALONG THE BRIDGE DECK AT ALL PANEL REPLACEMENT LOCATIONS

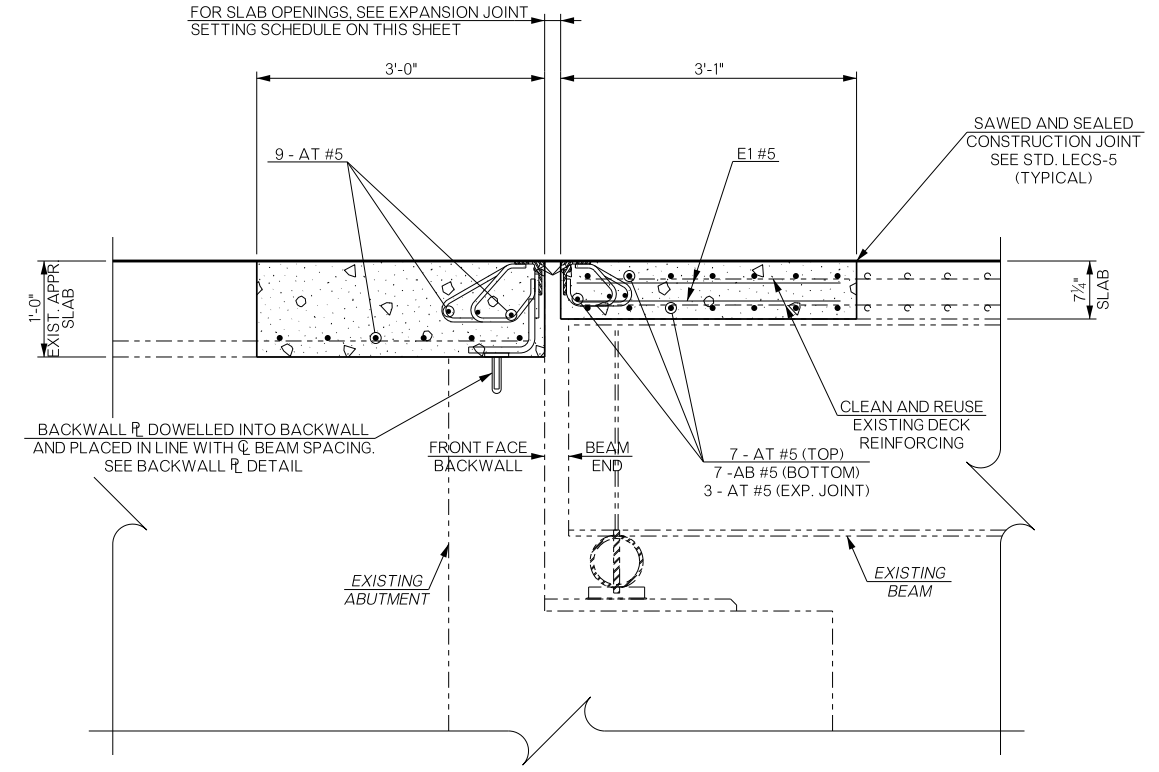

SLAB REPLACEMENT DETAIL AT Q BEAM

NOTE: DIMENSIONS ARE ALONG Q BEAM. ABUTMENT NO. 1 SHOWN; ABUTMENT NO. 2 OPPOSITE HAND

NOTE: DOWELING OF WELDED STUDS WILL BE IN ACCORDANCE WITH SECTION 509.04(D)3 OF THE STANDARD SPECIFICATIONS AND ALL COSTS TO BE INCLUDED IN THE UNIT PRICE BID PER LINEAR FOOT OF "SEALED EXPANSION JOINT".

JOINT OPENING	TEMPERATURE °F	
	ABUT. NO. 1	ABUT. NO. 2
2 1/4"	17	17
2 1/8"	39	39
2"	60	60
1 7/8"	81	81
1 3/4"	103	103

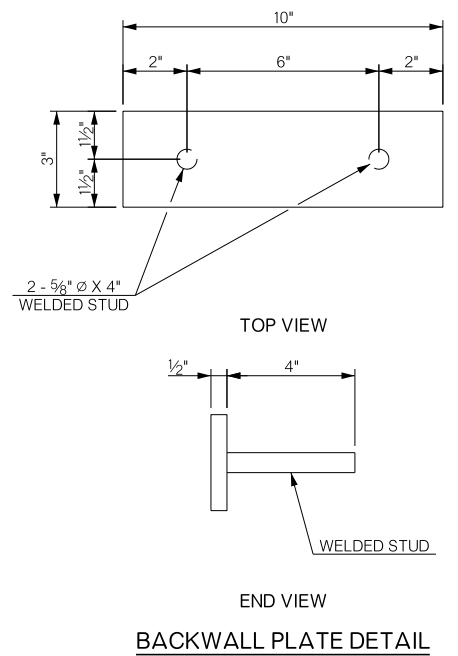

BACKWALL PLATE DETAIL

MARK	SIZE	NO.	FORM	LENGTH	LENGTH VARIATION
EPOXY COATED REINFORCING					
AB1	#5	7	BNT.	28'-9"	
AT1	#5	10	STR.	25'-10"	
AT2	#5	7	BNT.	4'-5"	
AT5	#5	9	STR.	26'-9"	
E1	#5	72	STR.	2'-9"	
PR1	#5	3	BNT.	5'-0"	
PR2	#5	2	BNT.	4'-1"	

NOTE: FOR BAR BEND DETAILS, SEE SHEET 14.

MARK	SIZE	NO.	FORM	LENGTH	LENGTH VARIATION
EPOXY COATED REINFORCING					
AB2	#5	7	BNT.	18'-3"	
AT3	#5	10	STR.	15'-10"	
AT4	#5	7	BNT.	3'-11"	
AT6	#5	9	STR.	16'-3"	
E1	#5	47	STR.	2'-9"	
PR1	#5	3	BNT.	5'-0"	
PR2	#5	2	BNT.	4'-1"	

ITEM	UNIT	PHASE I	PHASE II	TOTAL
SAW-CUT GROOVING	SY	16.00	9.40	25.40
CONCRETE PARAPET	LF	3.00	3.00	6.00
CLASS AA CONCRETE	CY	5.40	3.40	8.80
MECHANICAL SPLICES	EA			26.00
EPOXY COATED REINFORCING STEEL	LB	1,000.00	640.00	1,980.00
SEALED EXPANSION JOINT	LF	26.00	16.00	42.00

Design	
Drawn	
Checked	
Approved	
Squad	

CACHE ROAD OVER WOLF CREEK BRIDGES 'A' AND 'B' COMANCHE COUNTY
SUPERSTRUCTURE DETAILS
 EXPANSION JOINT DETAILS
 5 OF 8
 City Project EN2112 Sheet No. 19

4/4/2024 4:16:58 PM pw:\tochner-pw_bentley.com\tochner-pw-01\Documents\Projects\00018888\Z_Design\SHEET FILES\01-SUPERSTRUCTURE DETAILS.dgn

PROJECT DIST NO.	STATE	J.P. PROJECT NO.	FISCAL YEAR	SHEET NO.	TOTAL SHEETS
...	OKLA	---	---

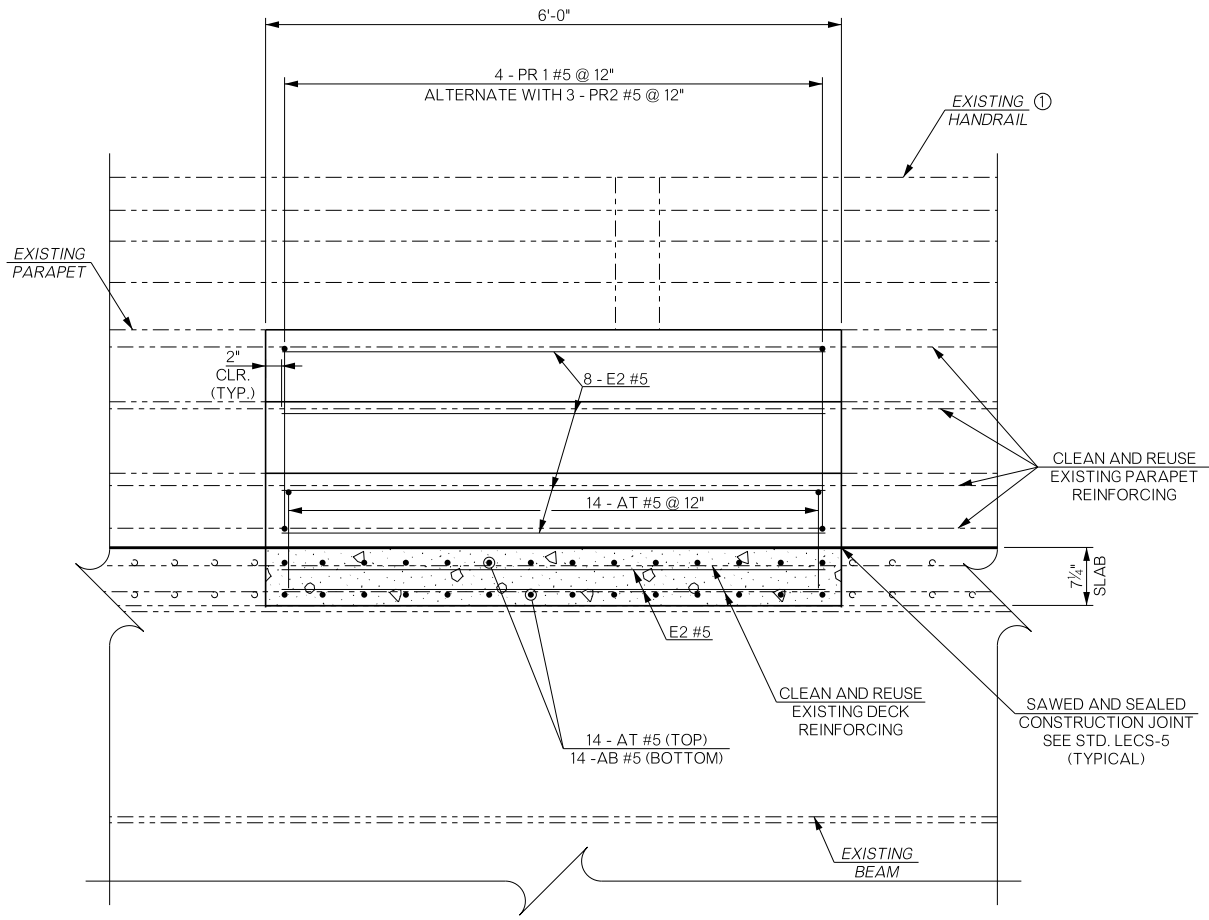

SLAB REPLACEMENT DETAIL AT PARAPET

① PROTECT IN PLACE. SUPPORT HANDRAIL DURING REMOVAL AND CONSTRUCTION OPERATIONS.

CONTRACTOR SHALL MAINTAIN THE EXISTING FINISHED GRADE ALONG THE BRIDGE DECK AT ALL PANEL REPLACEMENT LOCATIONS

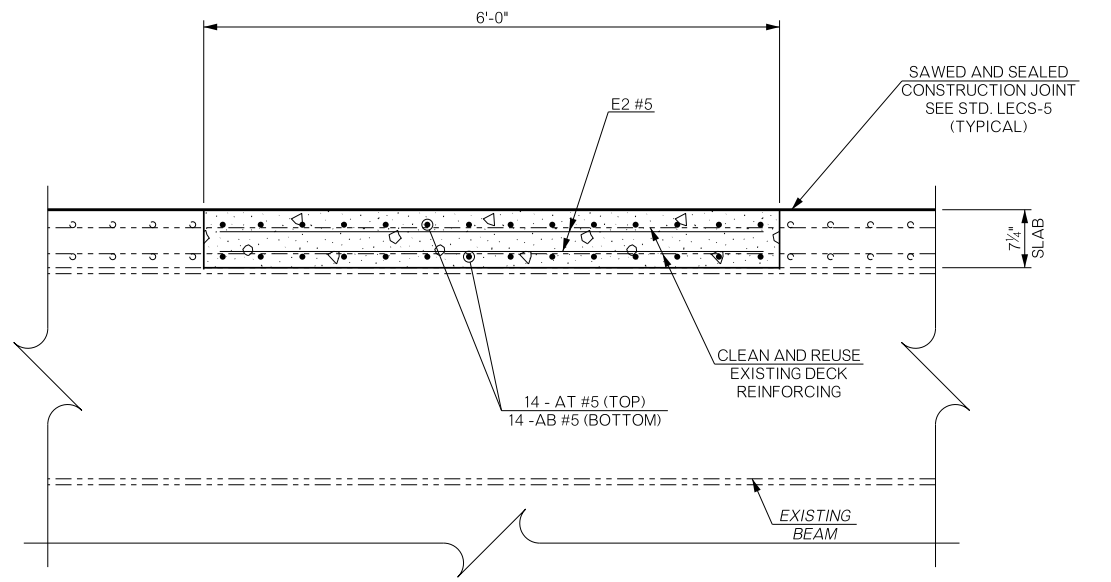

SLAB REPLACEMENT DETAIL

NOTE: DIMENSIONS ARE ALONG C BEAM.

CONSTRUCTION JOINT BAR LIST PHASE I (ONE SHOWN; TWELVE REQUIRED)					
MARK	SIZE	NO.	FORM	LENGTH	LENGTH VARIATION
EPOXY COATED REINFORCING					
AB1	#5	14	BNT.	28'-9"	
AT1	#5	14	STR.	25'-10"	
AT2	#5	14	BNT.	4'-5"	
E2	#5	72	STR.	5'-8"	
PR1	#5	4	BNT.	5'-0"	
PR2	#5	3	BNT.	4'-1"	

CONSTRUCTION JOINT BAR LIST PHASE II (ONE SHOWN; TWELVE REQUIRED)					
MARK	SIZE	NO.	FORM	LENGTH	LENGTH VARIATION
EPOXY COATED REINFORCING					
AB2	#5	14	BNT.	18'-3"	
AT3	#5	14	STR.	15'-10"	
AT4	#5	14	BNT.	3'-11"	
E2	#5	47	STR.	5'-8"	
PR1	#5	4	BNT.	5'-0"	
PR2	#5	3	BNT.	4'-1"	

CONSTRUCTION JOINT QUANTITIES (ONE SHOWN; TWELVE REQUIRED)				
ITEM	UNIT	PHASE I	PHASE II	TOTAL
SAW-CUT GROOVING	SY	16.00	9.40	25.40
CONCRETE PARAPET	LF	6.00	6.00	12.00
CLASS AA CONCRETE	CY	4.30	2.80	7.10
MECHANICAL SPLICES	EA			28.00
EPOXY COATED REINFORCING STEEL	LB	1,730.00	1,150.00	2,880.00

NOTE: FOR BAR BEND DETAILS, SEE SHEET 15

Design		CACHE ROAD OVER WOLF CREEK BRIDGES 'A' AND 'B' SUPERSTRUCTURE DETAILS CONSTRUCTION JOINT DETAILS 6 OF 8 City Project <u>EN2112</u> Sheet No. <u>20</u>
Drawn		
Checked		
Approved		
Squad		

4/4/2024 4:17:07 PM p:\tochner-pw_bentley.com\tochner-pw-01\Documents\Projects\00018888\Z_Design\SHEET FILES\002-SUPERSTRUCTURE DETAILS.dgn

PROJECT DIST NO.	STATE	APP. PROJ. NO.	FISCAL YEAR	SHEET NO.	TOTAL SHEETS
..	OKLA	*****	**	---	---

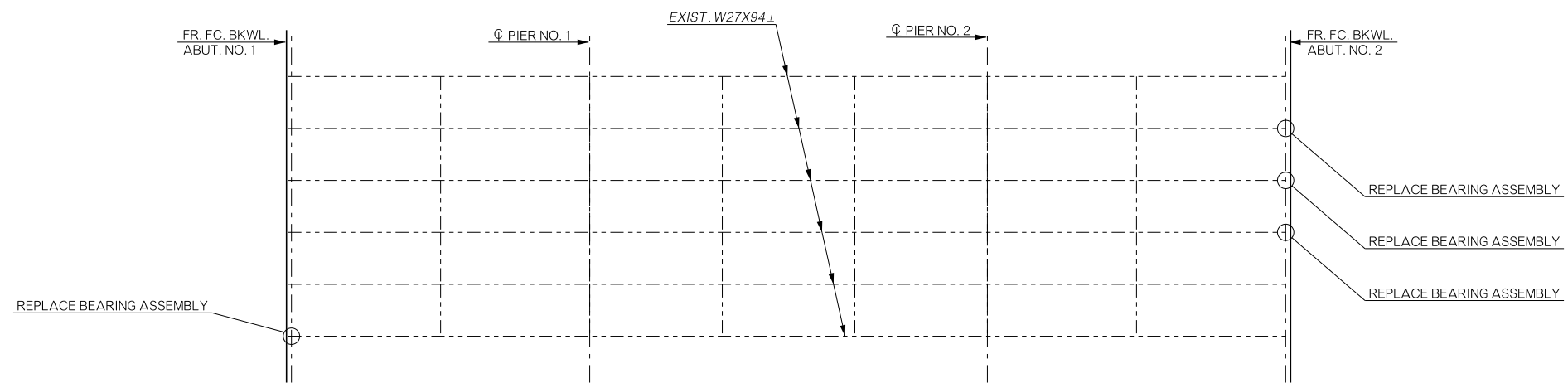
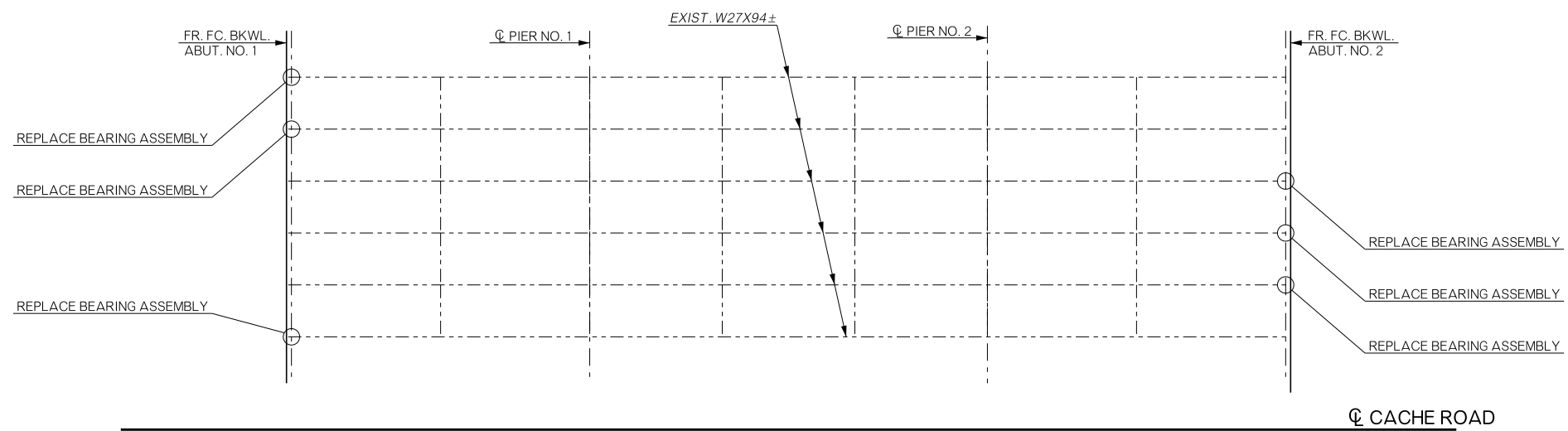

SPAN NO. 1

SPAN NO. 2

SPAN NO. 3

BEARING REPLACEMENT PLAN

☉ CACHE ROAD



Design	
Drawn	
Checked	
Approved	
Squad	

CACHE ROAD OVER WOLF CREEK
BRIDGES 'A' AND 'B' COMANCHE COUNTY

SUPERSTRUCTURE DETAILS
BEARING REPLACEMENT DETAILS
7 OF 8

PROJECT DIST NO.	STATE	JEP PROJ NO.	FISCAL YEAR	SHEET NO.	TOTAL SHEETS
.	OKLA	*****	**		----

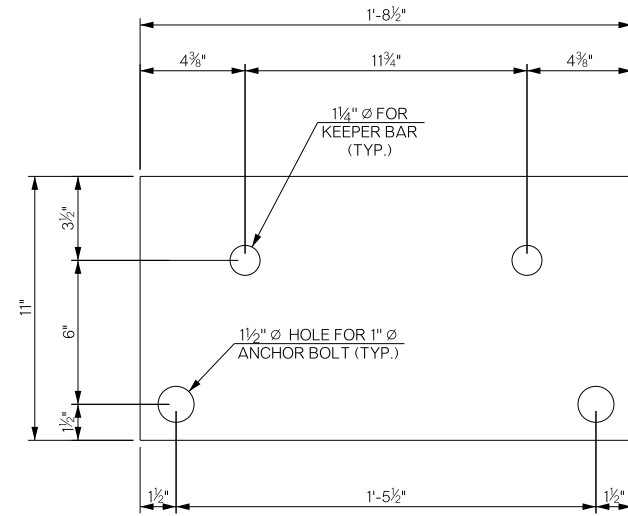

PLAN OF EXPANSION BEARING PLATE

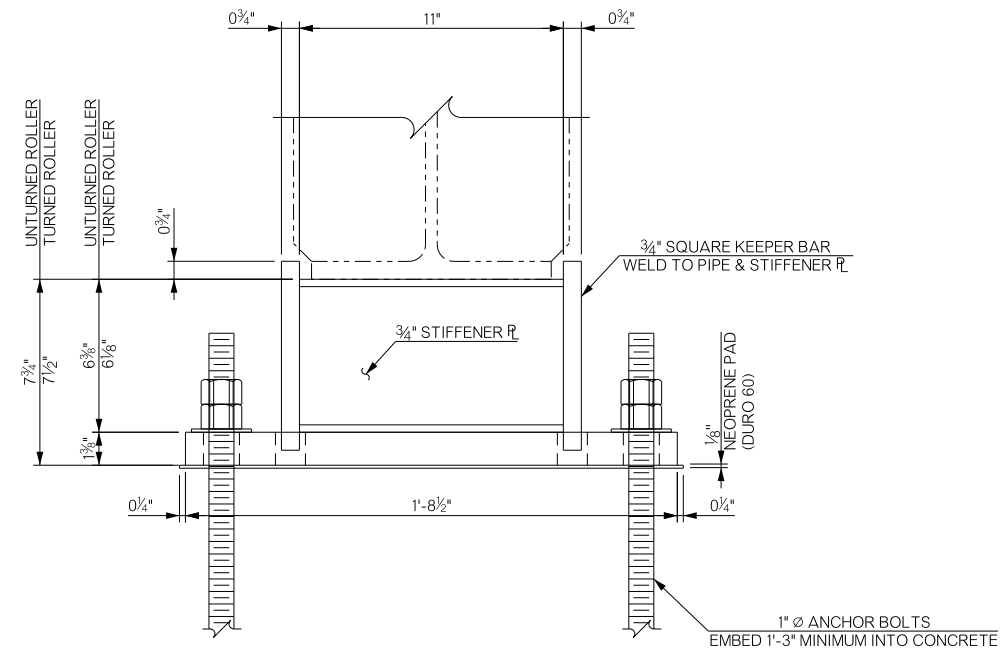

ELEVATION

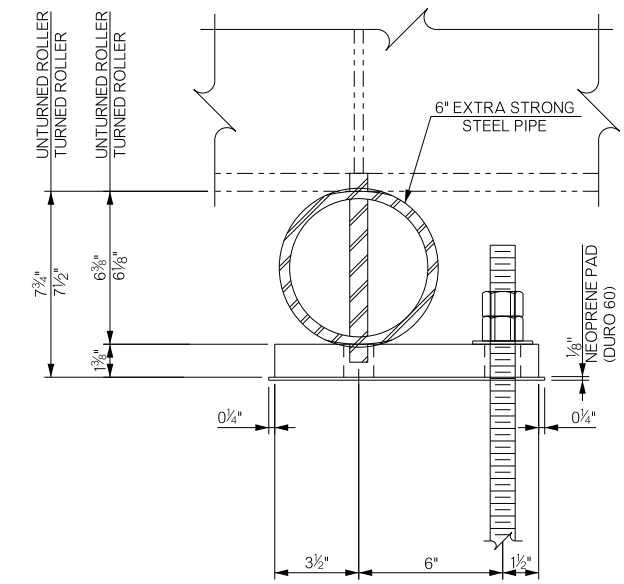

END VIEW

DETAIL OF EXPANSION SHOES

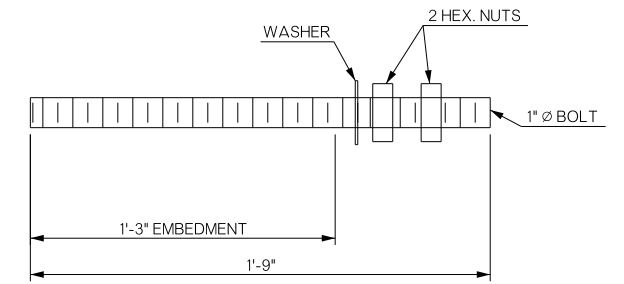

ANCHOR BOLT DETAIL

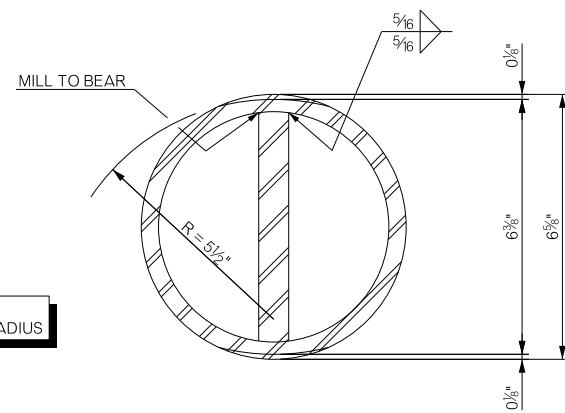

SECTION THRU ROLLER

NOTE:
ROLLER TO BE TURNED TO 5 1/2" RADIUS

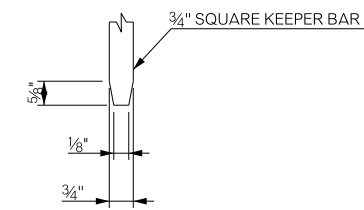

KEEPER DETAIL

Design		CACHE ROAD OVER WOLF CREEK	COMANCHE COUNTY
Drawn		BRIDGES 'A' AND 'B'	
Checked		SUPERSTRUCTURE DETAILS	
Approved		BEARING REPLACEMENT DETAILS	
Squad		8 OF 8	
		City Project	EN2112
		Sheet No.	22

PROJECT DIST NO.	STATE	APP'G PROJ NO.	FISCAL YEAR	SHEET NO.	TOTAL SHEETS
..	OKLA	*****	**	---	---

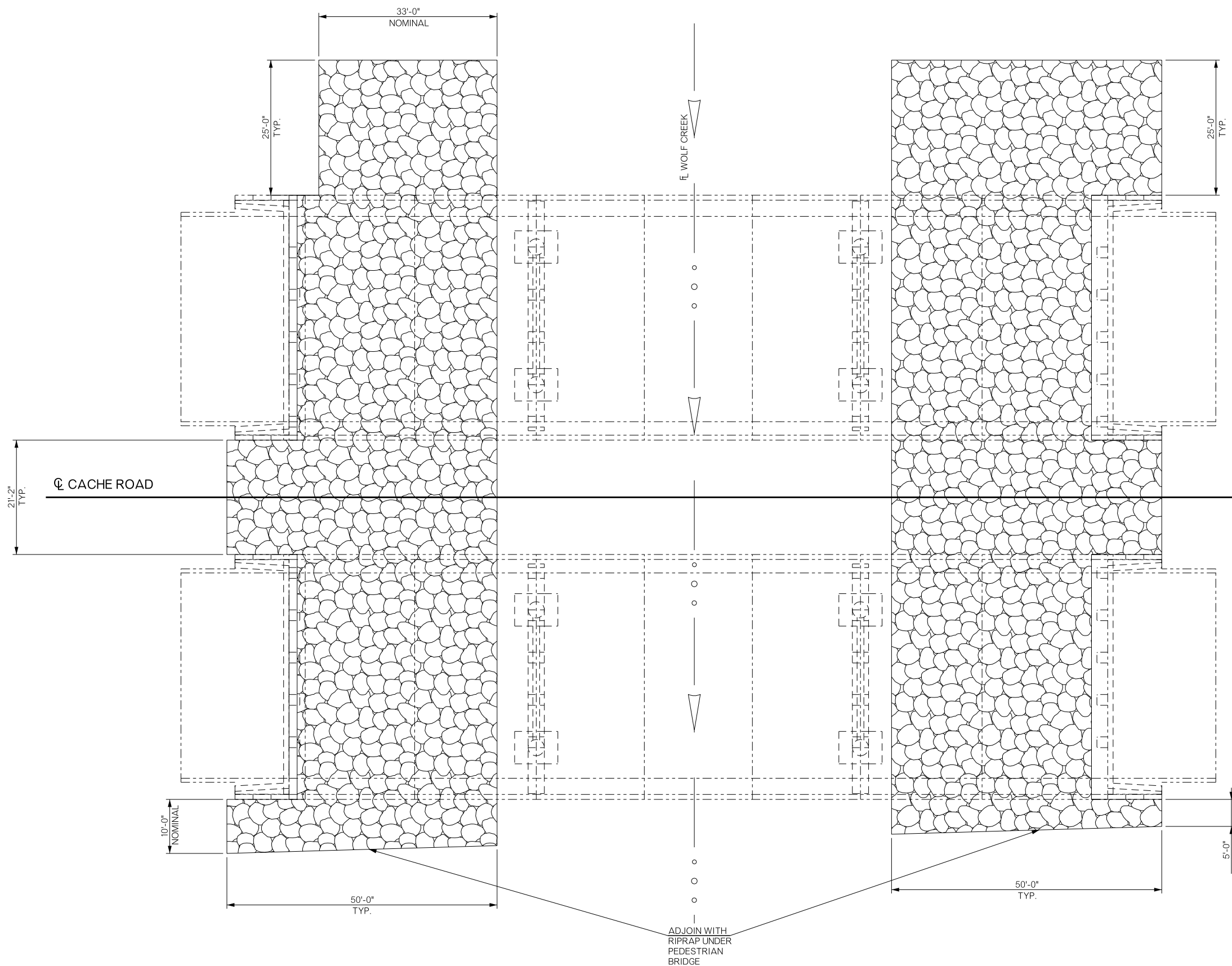

PLAN

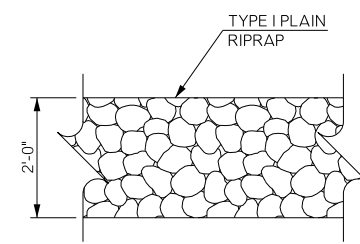

SECTION THRU RIPRAP

Design	
Drawn	
Checked	
Approved	
Squad	

CACHE ROAD OVER WOLF CREEK
BRIDGES 'A' AND 'B' COMANCHE COUNTY

RIPRAP PLAN

PROJECT DISTRICT	STATE	APPROVED	FISCAL YEAR	SHEET NO.	TOTAL SHEETS
.	OKLA	*****	**		

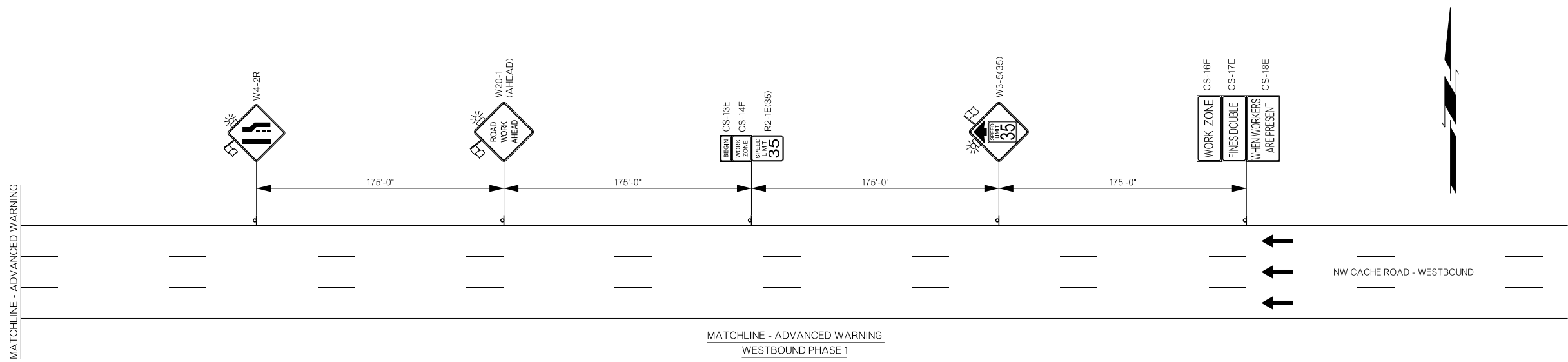

MATCHLINE - ADVANCED WARNING
WESTBOUND PHASE 1

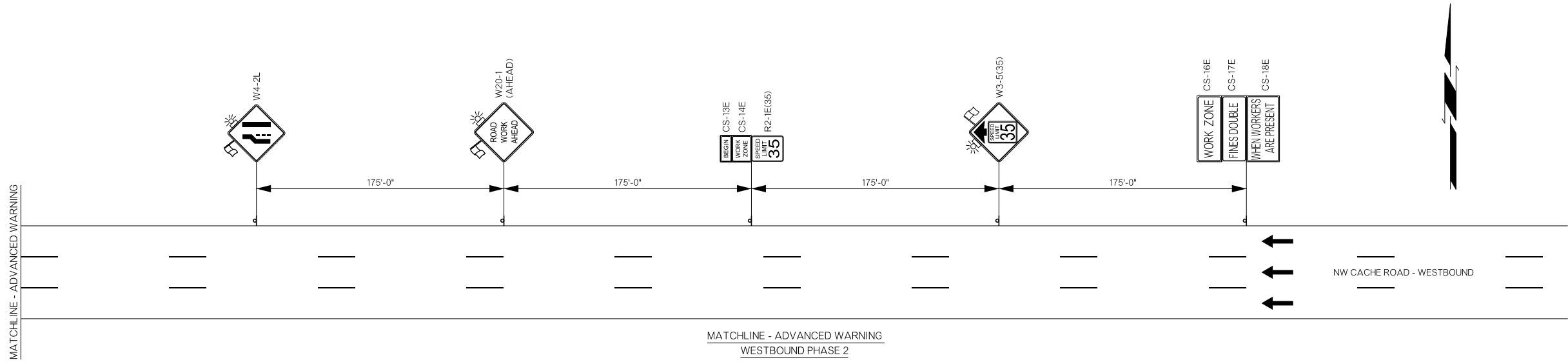

MATCHLINE - ADVANCED WARNING
WESTBOUND PHASE 2

THE CONTRACTOR SHALL COORDINATE ALL WORK WITH CITY OF LAWTON PROJECT PU2202. COORDINATION SHALL INCLUDE THE CITY OF LAWTON, ENGINEER AND CONTRACTOR FOR PROJECT PU2202 AND EN2112.

Design		CACHE ROAD OVER WOLF CREEK	COMANCHE COUNTY
Drawn		ADVANCE WARNING SIGNING DETAIL PHASE 1 & 2	
Checked			
Approved			
Squad			
City Project		EN2112	Sheet No. 24

PROJECT DISTRICT	STATE	PROJECT NO.	FISCAL YEAR	SHEET NO.	TOTAL SHEETS
.	OKLA	*****	**		

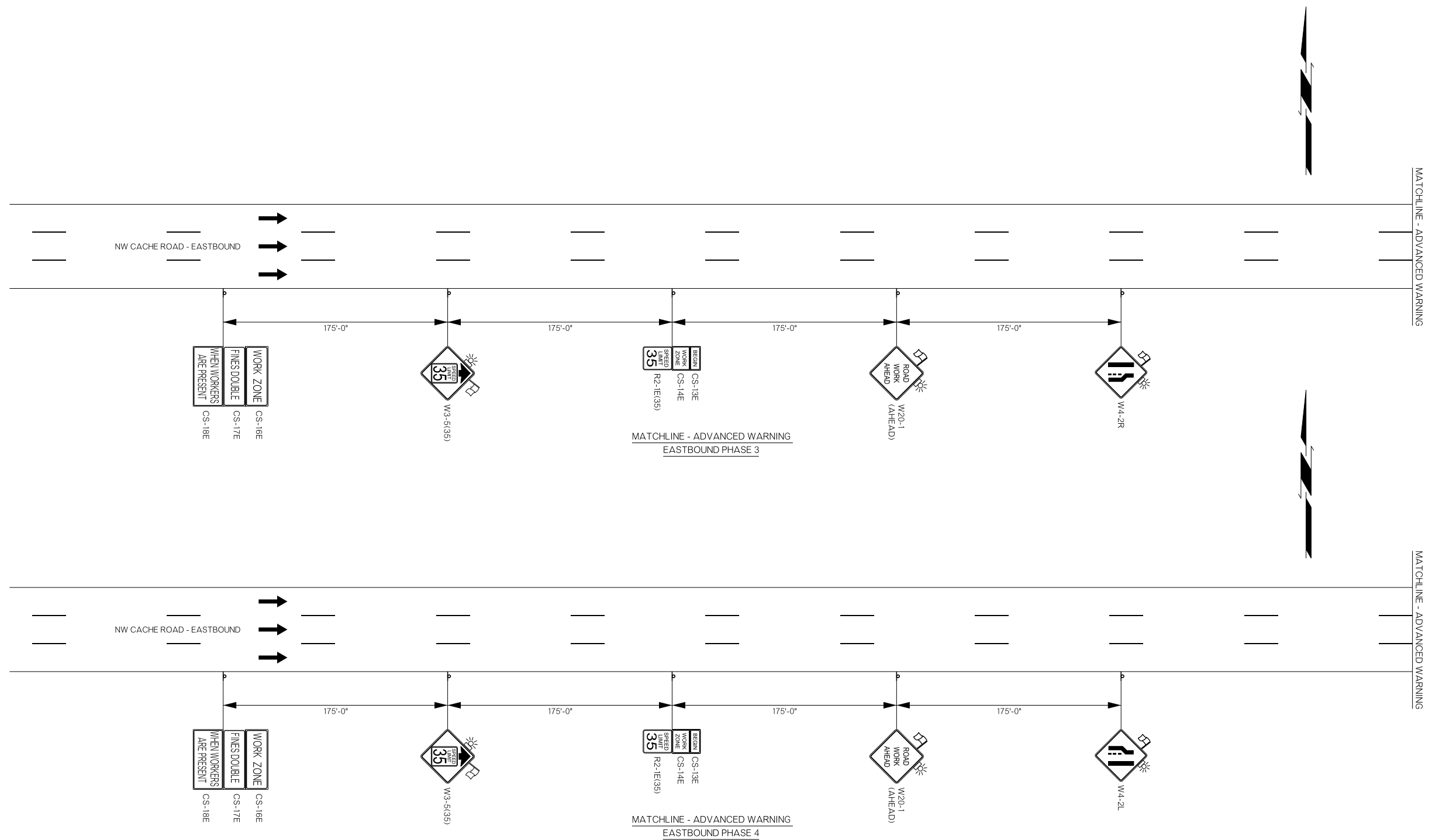

THE CONTRACTOR SHALL COORDINATE ALL WORK WITH CITY OF LAWTON PROJECT PU2202. COORDINATION SHALL INCLUDE THE CITY OF LAWTON, ENGINEER AND CONTRACTOR FOR PROJECT PU2202 AND EN2112.

Design		CACHE ROAD OVER WOLF CREEK	COMANCHE COUNTY
Drawn		ADVANCE WARNING SIGNING DETAIL PHASE 3 & 4	
Checked			
Approved			
Squad			
		City Project	EN2112
		Sheet No.	25

4/15/2024 10:10:55 AM p:\tochner-pw_bentley.com\tochner-pw-01\Documents\Projects\00018888Z_Design\SHEET FILES\0025-ADVANCE WARNING.dgn

PROJECT DISTRICT	STATE	PROJECT NO.	FISCAL YEAR	SHEET NO.	TOTAL SHEETS
.	OKLA		

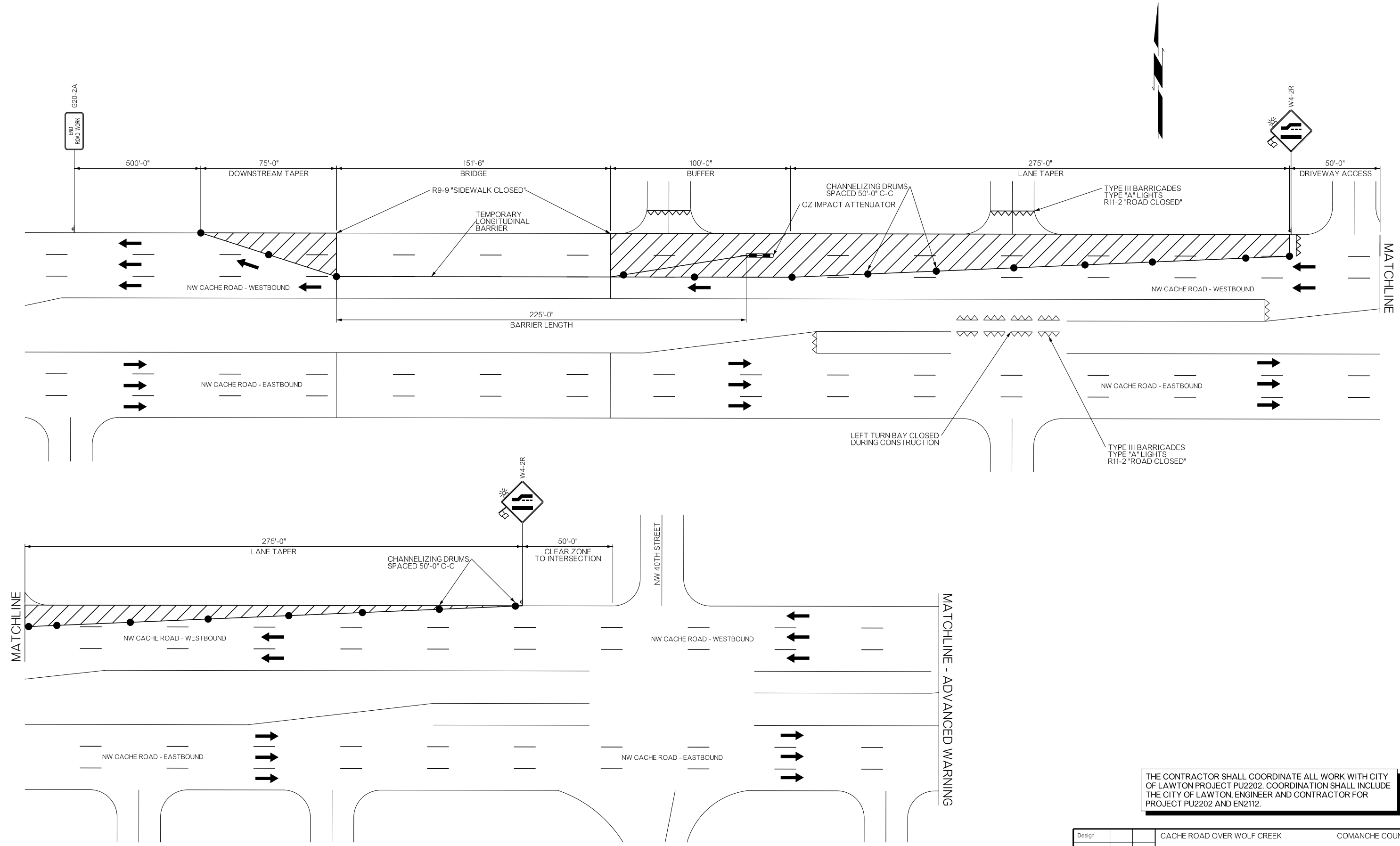

THE CONTRACTOR SHALL COORDINATE ALL WORK WITH CITY OF LAWTON PROJECT PU2202. COORDINATION SHALL INCLUDE THE CITY OF LAWTON, ENGINEER AND CONTRACTOR FOR PROJECT PU2202 AND EN2112.

Design		CACHE ROAD OVER WOLF CREEK	COMANCHE COUNTY
Drawn		SUGGESTED CONSTRUCTION SEQUENCE PHASE 1	
Checked			
Approved			
Squad			
		City Project	EN2112
		Sheet No.	26

PROJECT DISTRICT	STATE	PROJECT NO.	FISCAL YEAR	SHEET NO.	TOTAL SHEETS
OKLA	OKLA	*****	*****	27	30

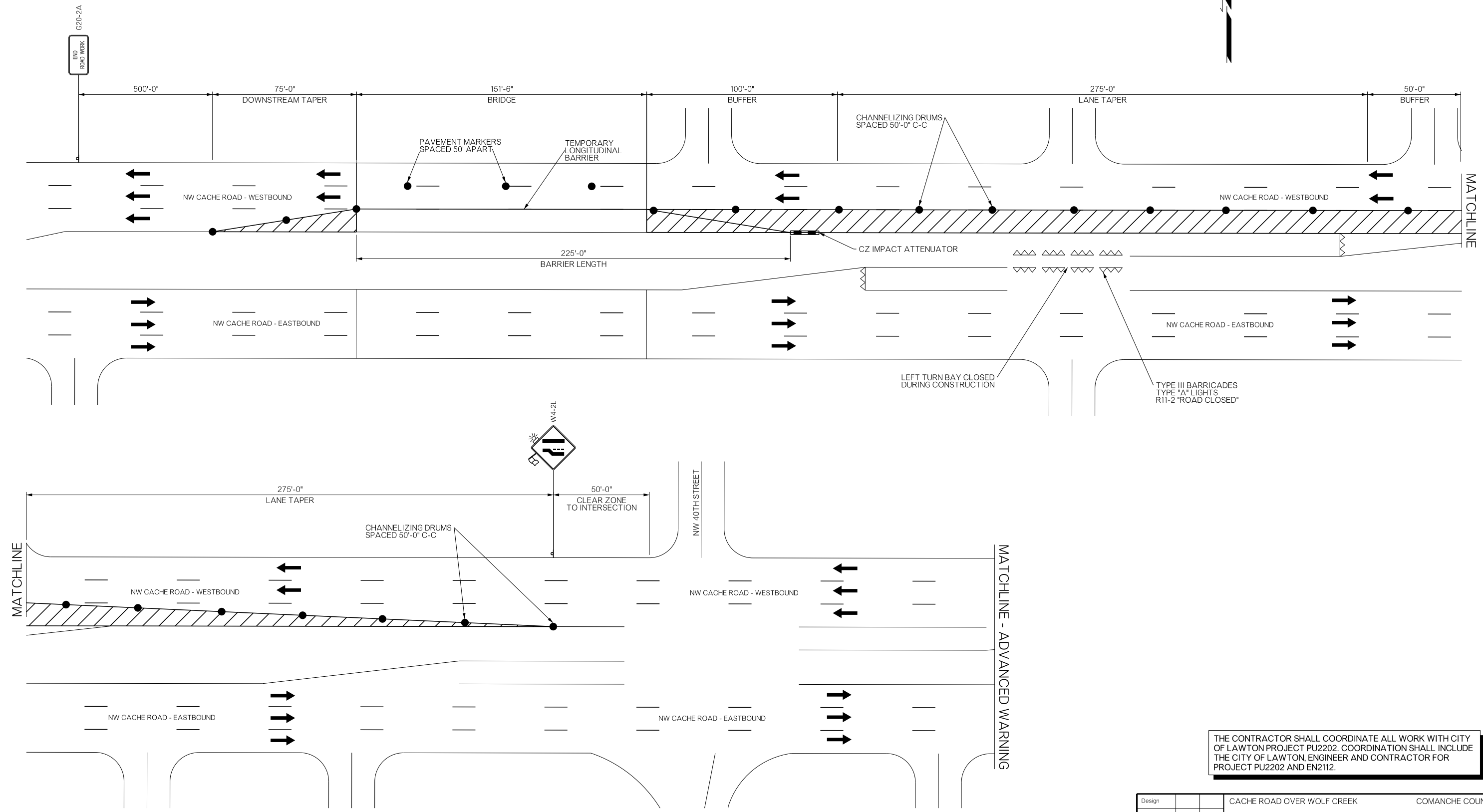

THE CONTRACTOR SHALL COORDINATE ALL WORK WITH CITY OF LAWTON PROJECT PU2202. COORDINATION SHALL INCLUDE THE CITY OF LAWTON, ENGINEER AND CONTRACTOR FOR PROJECT PU2202 AND EN2112.

Design		CACHE ROAD OVER WOLF CREEK	COMANCHE COUNTY
Drawn		SUGGESTED CONSTRUCTION SEQUENCE PHASE 2	
Checked			
Approved			
Squad			
		City Project	EN2112
		Sheet No.	27

PROJECT DISTRICT	STATE	PROJECT NO.	FISCAL YEAR	SHEET NO.	TOTAL SHEETS
OKLA	OKLA	*****	*****	28	30

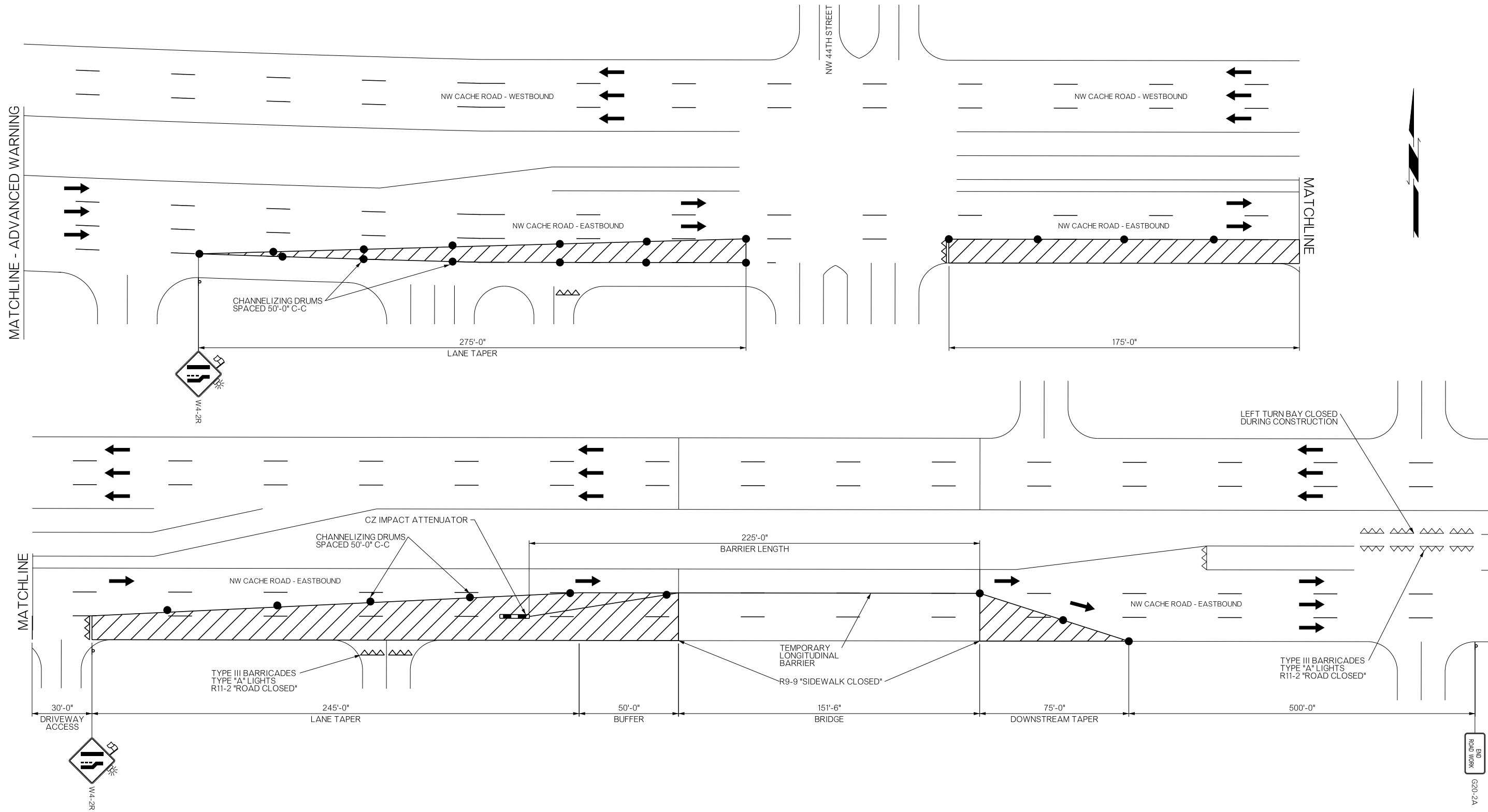

THE CONTRACTOR SHALL COORDINATE ALL WORK WITH CITY OF LAWTON PROJECT PU2202. COORDINATION SHALL INCLUDE THE CITY OF LAWTON, ENGINEER AND CONTRACTOR FOR PROJECT PU2202 AND EN2112.

Design	Drawn	Checked	Approved	Squad

CACHE ROAD OVER WOLF CREEK COMANCHE COUNTY
SUGGESTED CONSTRUCTION SEQUENCE
 PHASE 3
 City Project EN2112 Sheet No. 28

RD/ROAD DISTNO	STATE	APP/PROJNO	FISCAL YEAR	SHEET NO	TOTAL SHEETS
.	OKLA	*****	**		

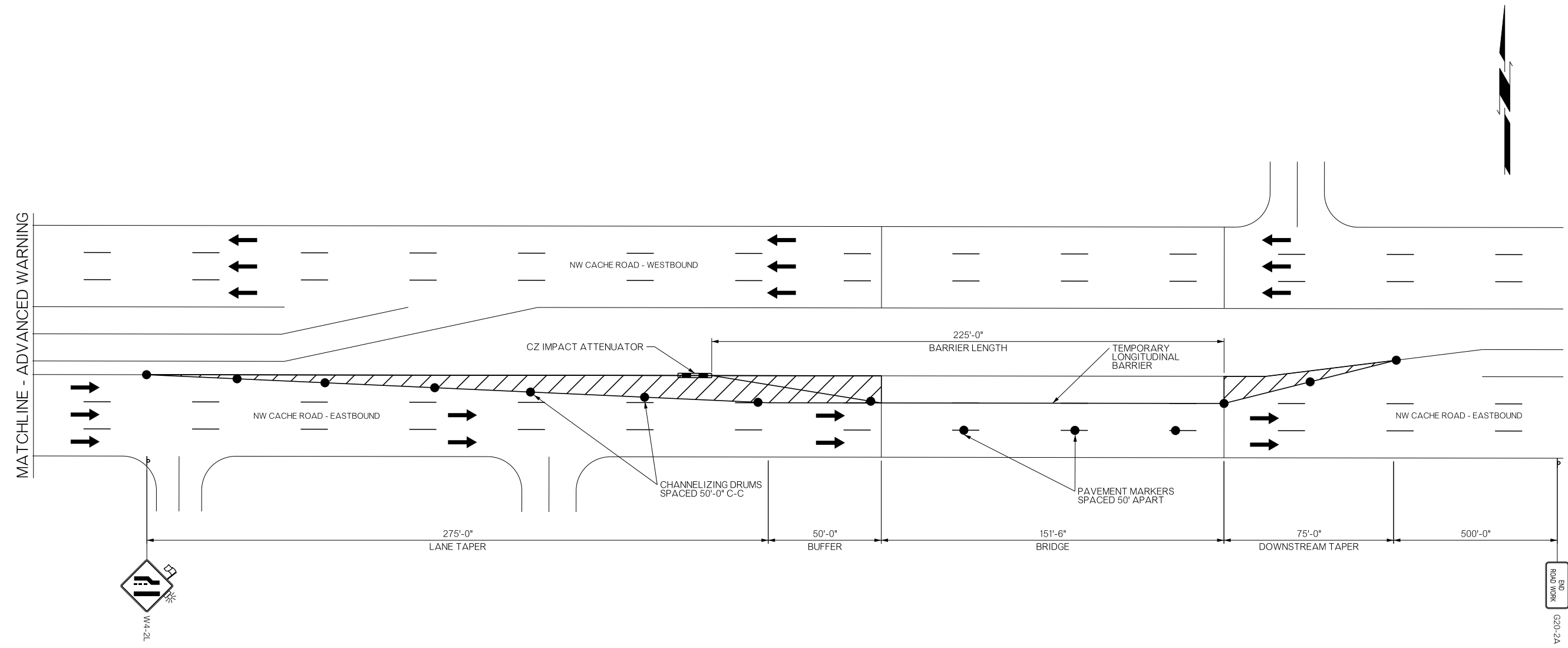

THE CONTRACTOR SHALL COORDINATE ALL WORK WITH CITY OF LAWTON PROJECT PU2202. COORDINATION SHALL INCLUDE THE CITY OF LAWTON, ENGINEER AND CONTRACTOR FOR PROJECT PU2202 AND EN2112.

Design		CACHE ROAD OVER WOLF CREEK	COMANCHE COUNTY
Drawn		SUGGESTED CONSTRUCTION SEQUENCE PHASE 4	
Checked			
Approved			
Squad			
		City Project	EN2112
		Sheet No.	29